

MSM6641/6641E-xx

Built-in Remote Control Transmission Circuit 4-Bit Microcontroller

GENERAL DESCRIPTION

The MSM6641, powered by a single battery, is a 4-bit microcontroller fabricated in OKI's low-voltage CMOS technology. A remote-control output generator built into this device provides remote-control output.

The MSM6641 is best suited to remote-control applications.

FEATURES

- Operating range
 - Operating voltage : 1.5 V (MSM6641)
3.0 V (MSM6641E)
 - Operating frequency : 1 MHz
 - Operating temperature : -20 to +70°C
- Memory space
 - ROM : 4096 words × 17 bits
 - RAM : 64 words × 4 bits
- Minimum instruction execution time : 16 μs
- I/O port
 - Input port : 2 ports × 4 bits
1 port × 1 bit
 - Output port : 2 ports × 4 bits
1 port × 1 bit
- Remote-control output port : 1
 - The remote-control output circuit consists of a carrier generator, a guide pulse and data pulse generator, and an output waveform controller.
 - The remote control output can be provided by setting the control registers.
- Key-On Wake-Up function
 - Oscillation can be stopped to turn off microcontroller operation.
 - Application of predetermined input levels to the input ports turns on oscillation and microcontroller operation.
- Halt release timers : 4
 - Timer frequencies are selectable.
- Watchdog timers : 2
- Clock : 1 MHz ceralock resonator
- Power supply voltage : 1.5 V/3.0 V (mask option)
- Package:
 - 24-pin plastic SOP (SOP24-P-430-K) (Product name : MSM6641-xxGS-K, MSM6641E-xxGS-K)
 - Chip

xx indicates the code number.

BLOCK DIAGRAM

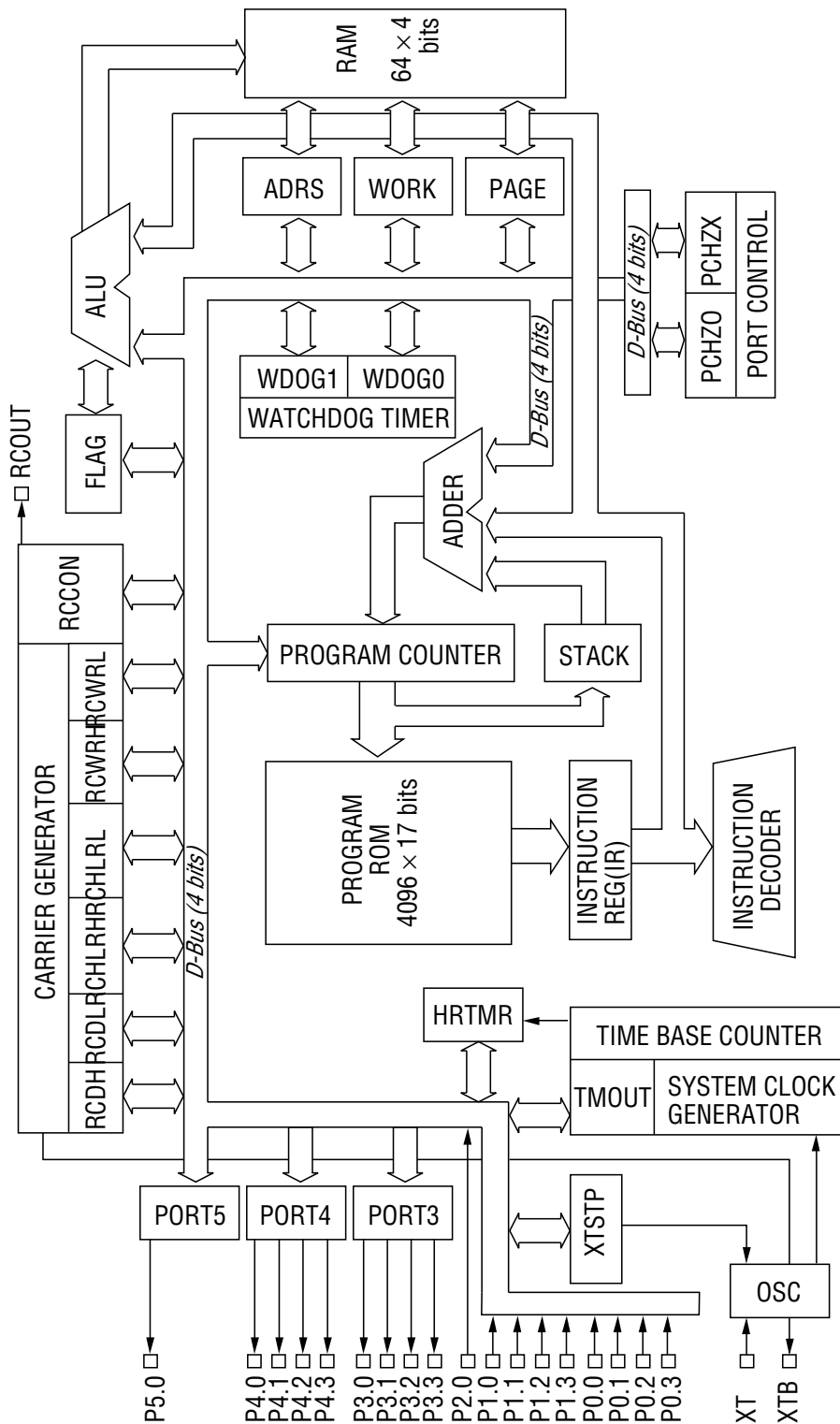

PIN CONFIGURATION (TOP VIEW)

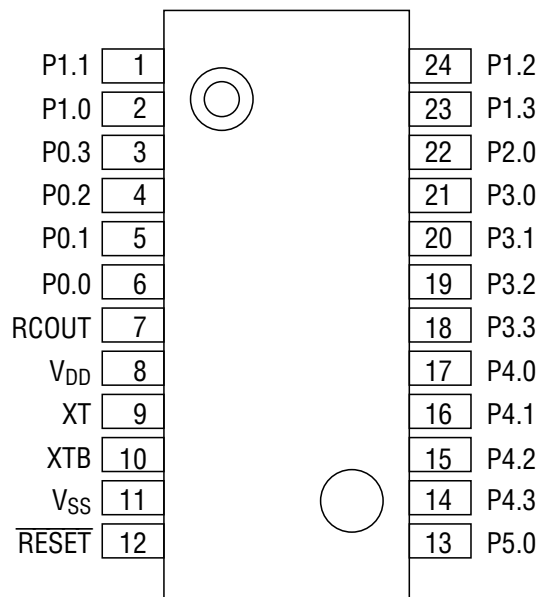

24-Pin Plastic SOP

PIN DESCRIPTIONS

Pin	Symbol	Type	Description	
8	V _{DD}	–	Power supply pin (1.5 V/3.0 V)	
11	V _{SS}	–	Ground pin	
9	XT	I	Oscillation input pin: a ceramic oscillator is connected.	
10	XTB	O	Oscillation output pin: a ceramic oscillator is connected.	
7	RCOUT	O	Remote control output pin: This pin outputs the remote control output set by the program. A "L" level is output at the time of reset.	
12	$\overline{\text{RESET}}$	I	System reset input pin: when a "L" level is applied to this pin, the microcontroller's internal state is initialized and the program starts from ROM address 000H.	
6 5 4 3	PORT 0	P0.0 P0.1 P0.2 P0.3	I	4-bit input port: normally used as the input of key matrix. A pull-down resistor or high impedance can be selected for each bit by the input pull-down control register (PCHZO) of PORT0.
2 1 24 23	PORT 1	P1.0 P1.1 P1.2 P1.3	I	4-bit input port: normally used as the input of key matrix. A pull-down resistor or high impedance for PORT1 can be selected by bit 0 of input pull-down control register (PCHZX) of PORTS1 and 2.
22	PORT 2	P2.0	I	1-bit input port: normally used as the input of key matrix. A pull-down resistor or high impedance for P2.0 can be selected by bit 1 of input pull-down control register (PCHZX) of PORTS1 and 2.
21 20 19 18	PORT 3	P3.0 P3.1 P3.2 P3.3	O	4-bit output port: normally used as the key return signal source of key matrix.
17 16 15 14	PORT 4	P4.0 P4.1 P4.2 P4.3	O	4-bit output port: normally used as the key return signal source of key matrix.
13	PORT 5	P5.0	O	1-bit output port: normally used as the key return signal source of key matrix.

ABSOLUTE MAXIMUM RATINGS (MSM6641) $V_{SS}=0\text{ V}$

Parameter	Symbol	Condition	Rating	Unit
Power Supply Voltage	V_{DD}	$T_a=25^\circ\text{C}$	-0.3 to +6.0	V
Input Voltage	V_{IN}		-0.3 to $V_{DD}+0.3$	
Output Voltage	V_O		-0.3 to $V_{DD}+0.3$	
Storage Temperature	T_{STG}	—	-55 to +125	$^\circ\text{C}$

RECOMMENDED OPERATING CONDITIONS (MSM6641) $V_{SS}=0\text{ V}$

Parameter	Symbol	Condition	Range	Unit
Power Supply Voltage	V_{DD}	—	+1.2 to +3.5	V
Operating Temperature	T_{op}	—	-20 to +70	$^\circ\text{C}$
Oscillation Frequency	f_{OSC}	—	0.9 to 1.1	MHz

ELECTRICAL CHARACTERISTICS (MSM6641)**DC Characteristics** $(V_{DD}=1.5\text{ V}, V_{SS}=0\text{ V}, f_{OSC}=1\text{ MHz}, T_a=25^\circ\text{C})$

Parameter	Symbol	Condition	Min.	Typ.	Max.	Unit	Applied Pin
Operating Current Consumption	I_{DD}	At remote control output *1	—	300	600	μA	—
Static Current Consumption	I_{DDs}	During standby (XTSTP="1")	—	—	1	μA	—
Oscillation Start Voltage	V_{OSC}	—	—	—	1.2	V	—
Output Current 1	$-I_{OH1}$	$V_O=1.0\text{ V}$	150	—	—	μA	PORT3 to PORT5 *2
	I_{OL1}	$V_O=0.5\text{ V}$	150	—	—		
Output Current 2	$-I_{OH2}$	$V_O=1.0\text{ V}$	500	—	—	μA	RCOUT
	I_{OL2}	$V_O=0.5\text{ V}$	2	—	—		
Input Current 1	I_{IH1}	$V_I=1.5\text{ V}$, input state, with pull-down resistor	3.75	7.5	15	μA	PORT0 to PORT2 *3
Input Leakage Current	$ I_{IL} $	$V_I=1.5\text{ V}/0\text{ V}$, input state, without pull-down resistor	—	—	1	μA	PORT0 to PORT2 *3
Input Current 2	$-I_{IL2}$	$V_I=0\text{ V}$, with pull-up resistor	75	150	300	μA	$\overline{\text{RESET}}$
Input Voltage	V_{IH}	—	1.2	—	—	V	All input pins
	V_{IL}		—	—	0.3		

*1 The frequency is 333 kHz, in carrier-through state

*2 PORT3=P3.0 to P3.3, PORT4=P4.0 to P4.3, PORT5=P5.0

*3 PORT0=P0.0 to P0.3, PORT1=P1.0 to P1.3, PORT2=P2.0

ABSOLUTE MAXIMUM RATINGS (MSM6641E)V_{SS}=0 V

Parameter	Symbol	Condition	Rating	Unit
Power Supply Voltage	V _{DD}	Ta=25°C	-0.3 to +6.0	V
Input Voltage	V _{IN}		-0.3 to V _{DD} +0.3	
Output Voltage	V _O		-0.3 to V _{DD} +0.3	
Storage Temperature	T _{STG}	—	-55 to +125	°C

RECOMMENDED OPERATING CONDITIONS (MSM6641E)V_{SS}=0 V

Parameter	Symbol	Condition	Range	Unit
Power Supply Voltage	V _{DD}	—	+2.0 to +3.5	V
Operating Temperature	T _{op}	—	-20 to +70	°C
Oscillation Frequency	f _{OSC}	—	0.9 to 1.1	MHz

ELECTRICAL CHARACTERISTICS (MSM6641E)**DC Characteristics**(V_{DD}=3.0 V, V_{SS}=0 V, f_{OSC}=1 MHz, Ta=25°C)

Parameter	Symbol	Condition	Min.	Typ.	Max.	Unit	Applied Pin
Operating Current Consumption	I _{DD}	At remote control output *1	—	1	2	mA	—
Static Current Consumption	I _{DDs}	During standby (XTSTP="1")	—	—	1	μA	—
Oscillation Start Voltage	V _{OSC}	—	—	—	2.0	V	—
Output Current 1	-I _{OH1}	V _O =2.5 V	500	—	—	μA	PORT3 to PORT5 *2
	I _{OL1}	V _O =0.5 V	500	—	—		
Output Current 2	-I _{OH2}	V _O =2.5 V	1.5	—	—	mA	RCOUT
	I _{OL2}	V _O =0.5 V	6	—	—		
Input Current 1	I _{IH1}	V _I =3.0 V, input state, with pull-down resistor	25	50	100	μA	PORT0 to PORT2 *3
Input Leakage Current	I _{IIL1}	V _I =3.0 V/0 V, input state, without pull-down resistor	—	—	1	μA	PORT0 to PORT2 *3
Input Current 2	-I _{IIL2}	V _I =0 V, with pull-up resistor	150	300	600	μA	RESET
Input Voltage	V _{IH}	—	2.5	—	—	V	All input pins
	V _{IL}		—	—	0.5		

*1 The frequency is 333 kHz, in carrier-through state

*2 PORT3=P3.0 to P3.3, PORT4=P4.0 to P4.3, PORT5=P5.0

*3 PORT0=P0.0 to P0.3, PORT1=P1.0 to P1.3, PORT2=P2.0