

MSM7570L-01/02**Multi-Function ADPCM CODEC****GENERAL DESCRIPTION**

The MSM7570L-01/02, developed for advanced digital cordless telephone systems, are single channel ADPCM CODEC ICs which perform mutual transcoding between the analog voice band signal and 32 kbps ADPCM serial data.

The devices include DTMF Tone and several types of tone generation, transmit/receive data mute and gain control, side-tone path and gain control, and VOX function.

Using advanced circuit technology, these devices operate from a single 3 V power supply and provide low power consumption.

Note: The MSM7570L-01 differs from MSM7570L-02 in Ringing Tone Frequency.

FEATURES

- Single 3 V Power Supply Operation V_{DD} : 2.7 V to 3.6 V
- ADPCM Algorithm : ITU-T G.726 (32 kbps, 24 kbps, 16 kbps)
- Full-Duplex Transmit/Receive Operation
- Transmit/Receive Synchronous Mode Only
- PCM Data Format : A-law/ μ -law Selectable
- Serial PCM/ADPCM Transmission Data Rate : 64 kbps to 2048 kbps
- Low Power Consumption
 - Operating Mode : 21 mW Typ. ($V_{DD} = 3.0$ V)
 - Power-Down Mode : 0.3 mW Typ. ($V_{DD} = 3.0$ V)
- Two Analog Input Amplifier Stages : Externally Adjustable Gain
- Analog Output Stage : Push-pull Drive (direct drive of 350 Ω + 120 nF)
- Master Clock Frequency : 12.288/19.200 MHz Selectable
- Transmit/Receive Mute, Transmit/Receive Programmable Gain Control
- Side Tone Path with Programmable Attenuation (8-step Level Adjustment)
- Built-in DTMF Tone Generator
- Built-in Various Ringing/Function Tones Generator
- Built-in Various Ring Back Tone Generator
- Serial MCU Interface Control
- Built-in Sounder Driving Amplifier
- Built-in VOX Control
 - Transmit side : Voice Signal Detect
 - Receive side : Background Noise Generation
- Characteristic Evaluation Board.
- Package:
 - 32-pin plastic TSOP (TSOPI32-P-814-0.50-1K) (Product name: MSM7570L-01TS-K)
 - (Product name: MSM7570L-02TS-K)

BLOCK DIAGRAM

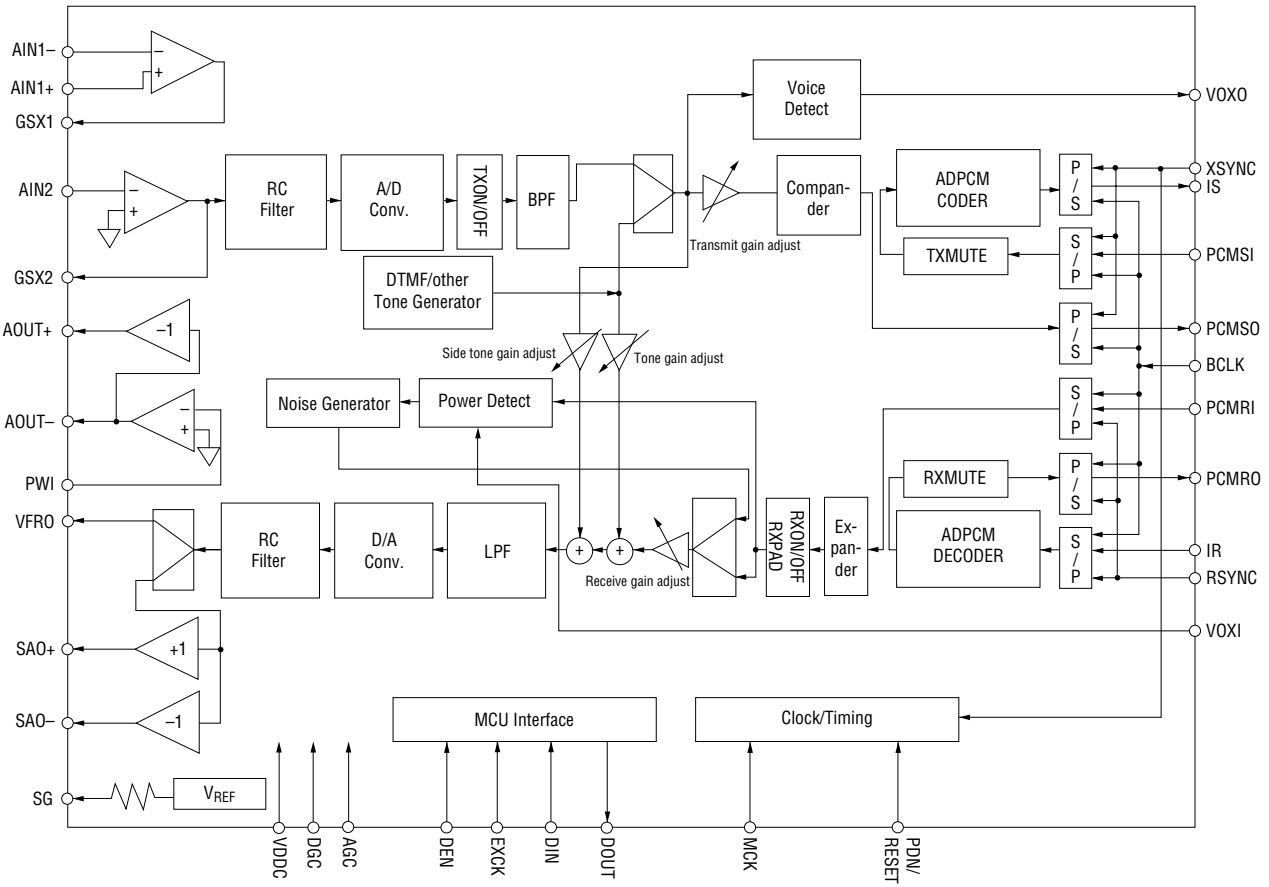

PIN CONFIGURATION (TOP VIEW)

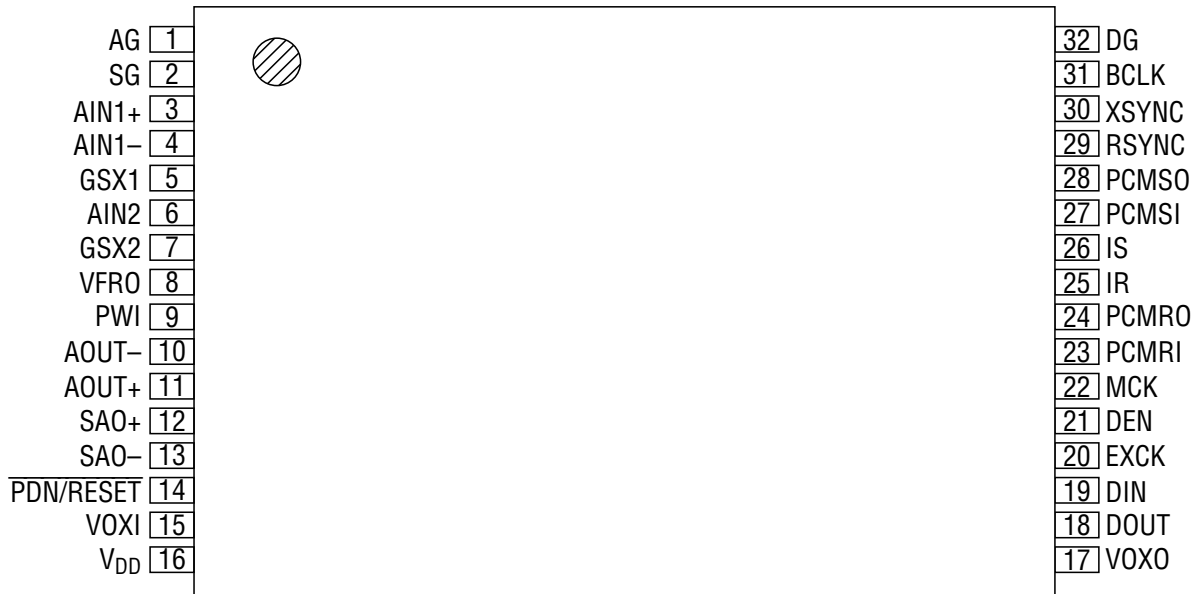

32-Pin Plastic TSOP

PIN AND FUNCTIONAL DESCRIPTIONS

AIN1+, AIN1-, AIN2, GSX1, GSX2

Transmits analog input and the output for transmit gain adjustment.
 AIN1- (AIN2) connects to the inverting input of the internal transmit amplifier. AIN1+ connects to the non-inverting input of the internal transmit amplifier. GSX1 (GSX2) connects to the internal transmit amplifier output. Refer to Fig.1 for gain adjustment.

VFRO, AOUT+, AOUT-, PWI

Receives analog output and the output for receive gain adjustment.
 VFRO is the receive filter output. AOUT+ and AOUT- are differential analog signal outputs which can directly drive $Z_L = 350 \Omega + 120 \text{ nF}$ or a 1.2 k Ω load. Refer to Fig.1 for gain adjustment.

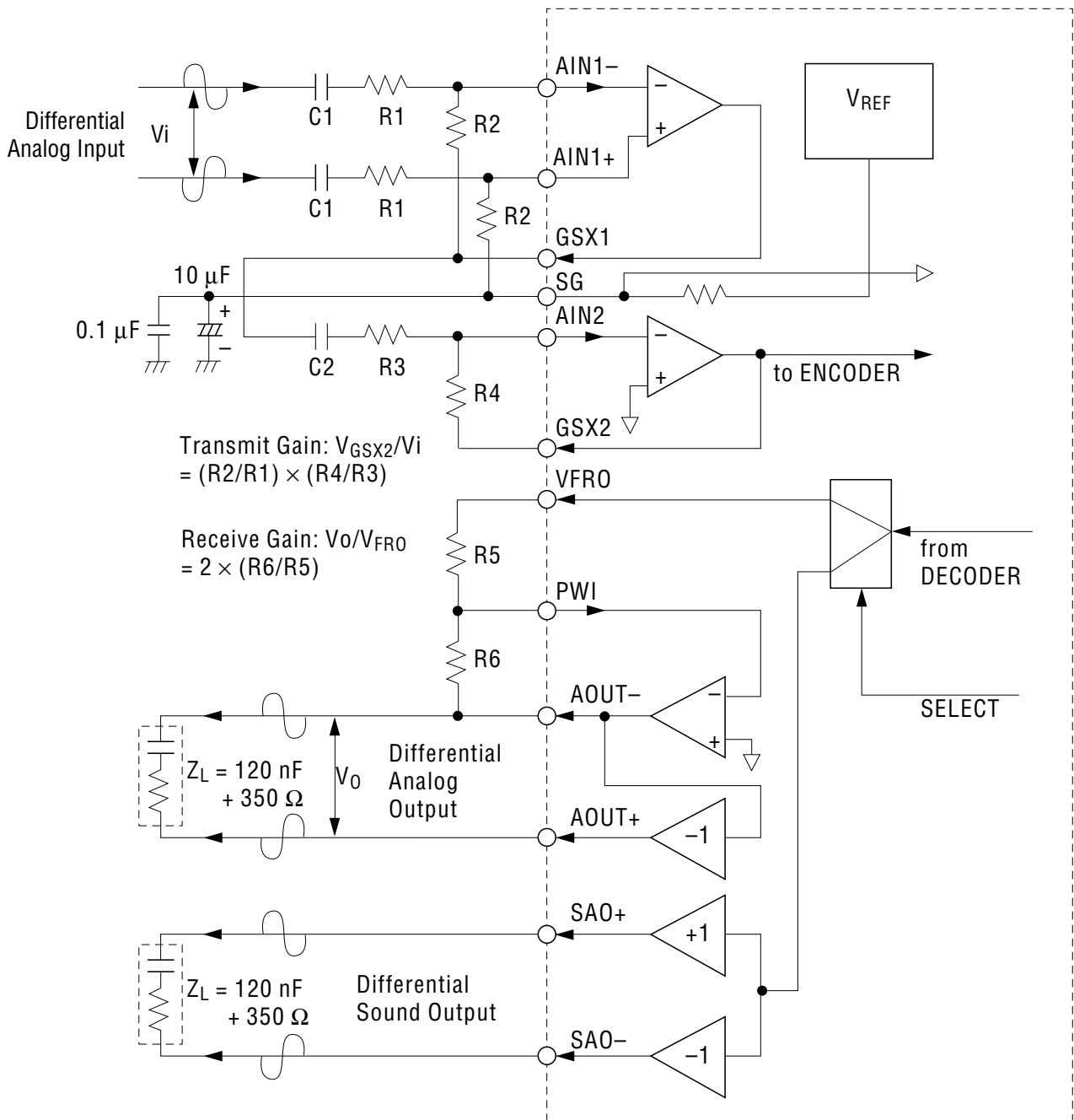

Figure 1 Analog Input/Output Interface

SAO+, SAO-

Differential analog outputs for sound output.

Control register data CR4-B5 determines the output pins (AOUT+ and AOUT- /SAO+ and SAO-) for the voice signal and an acoustic component of the sound tone, DTMF tone, R tone, F tone, and various types of tones at either the VFRO pin or the SAO+ and SAO- pins. The output load conditions of these pins are the same as those of AOUT+ and AOUT-.

SG

Analog signal ground.

The output voltage of this pin is approximately 1.4 V. Put the bypass capacitors (10 μ F in parallel with 0.1 μ F ceramic type) between this pin and AG to get the specified noise characteristics. During power-down, this output voltage is 0 V. The SG voltage if necessary should be used via a beffer.

AG

Analog ground.

DG

Digital ground.

This ground is separated from the analog signal ground pin (AG). The DG pin must be kept as close as possible to AG on the PCB.

V_{DD}

+3 V power supply.

PDN/RESET

Power down and reset control input.

A "0" level makes the IC enter a power down state. At the same time, all control register data are reset to the initial state. Set this pin to "1" during normal operating mode. The power down state is controlled by a logical OR with CR0-B5 of the control register. When using PDN/RESET for power down and reset control, set CR0-B5 to digital "0".

The reset width (during "L") should be 200ns or more.

MCK

Master clock input.

The frequency must be 12.288 MHz or 19.2 MHz. The applied clock frequency is selected by the control register data CR0-B6. The master clock signal may be asynchronous with BCLK, XSYNC, and RSYNC.

PCMSO

Transmit PCM data output.

PCM is output from MSB in synchronization with the rising edge of BCLK and XSYNC.

PCMSI

Transmit PCM data input.

This signal is converted to the transmit ADPCM data. PCM is shifted in synchronization with the falling edge of BCLK. Normally, this pin is connected to PCMSO.

PCMRO

Receive PCM data output.

PCM is the output signal after ADPCM decoder processing. This signal is output serially from MSB in synchronization with the rising edge of BCLK and RSYNC.

PCMRI

Receive PCM data input.

PCM is shifted on the rising edge of the BCLK and input from MSB. Normally, this pin is connected to PCMRO.

IS

Transmit ADPCM signal output.

After having encoded PCM with ADPCM, this signal is output from MSB in synchronization with the rising edge of BCLK and XSYNC. This pin is an open drain output and remains in a high impedance state during power-down. IS requires a pull-up resistor.

IR

Receive ADPCM signal input.

This input signal is shifted serially on the falling edge of BCLK in synchronization with RSYNC, and input from MSB.

BCLK

Shift clock input for the PCM data (PCMSO, PCMSI, PCMRO, PCMRI) and the ADPCM data (IS, IR).

The frequency is set in the 64 kHz to 2048 kHz range.

XSYNC

Transmit PCM and ADPCM data 8 kHz synchronous signal input.

Synchronize this signal with BCLK signal. XSYNC is used to indicate the MSB of the transmit serial PCM and ADPCM data stream.

Be sure to input the XSYNC signal because it is also used as the input of the timing generator.

RSYNC

Receive PCM and ADPCM data synchronous signal input.

Synchronize this signal with BCLK signal. RSYNC is used to indicate the MSB of the receive serial PCM and ADPCM data stream.

VOXO

Transmit VOX function signal output.

VOX function voice recognizes the presence or absence of the transmit voice signal by detecting the signal energy. "1" and "0" levels set on this pin correspond to the presence and the absence of voice, respectively. This result appears at the register data CR7-B7. The signal energy detect threshold is set by the control register data CR6-B6, B5.

VOXI

Signal input for receive VOX function.

A "1" level at VOXI indicates the presence of a voice signal. The decoder block processes normal receive signal, and the voice signal appears at the analog output pins. The "0" level indicates the absence of a voice signal. Background noise generated in this device is transferred to the analog output pins. The background noise amplitude is set by the control register CR6. Because this signal is ORed with the register data CR6-B3, set the control register data CR6-B3 to digital "0".

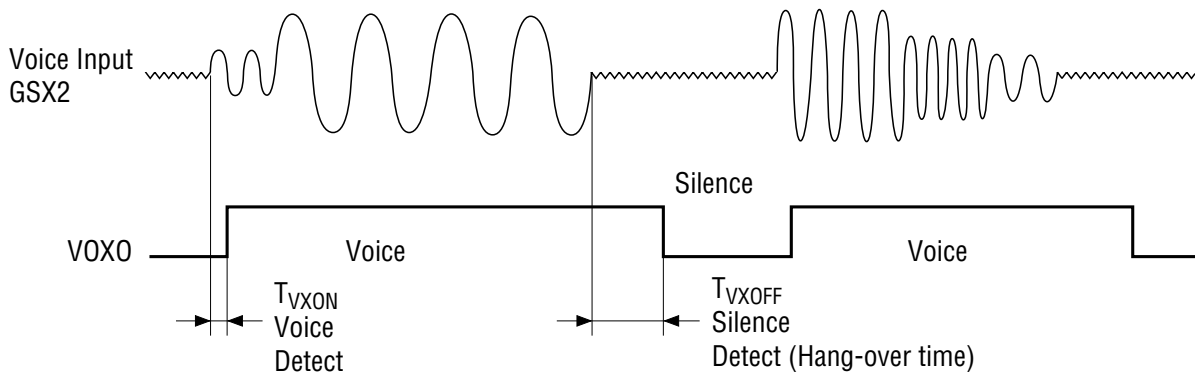

(a) Transmit VOX Function Timing Diagram

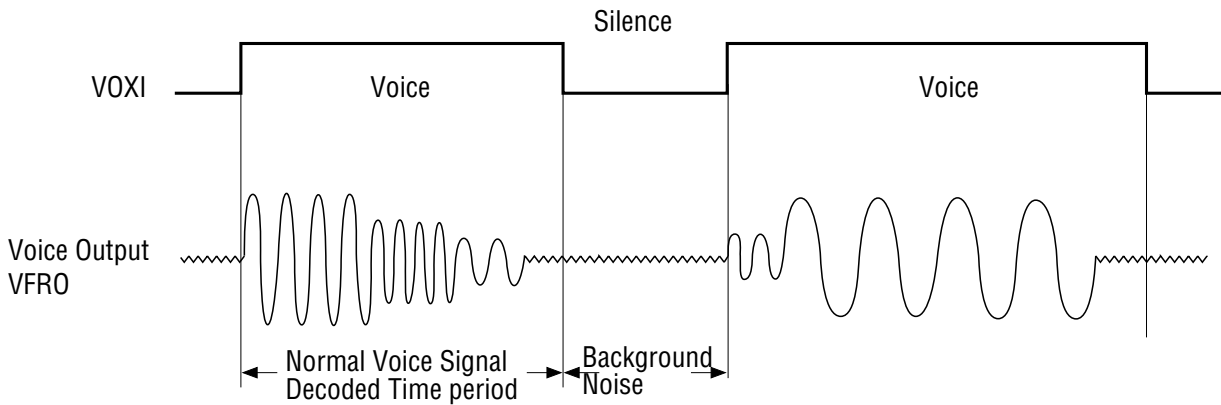

(b) Receive VOX Function (CR6-B3: digital "0") Timing Diagram

Note: VOXO, VOXI functions becomes valid when setting CR6-B7 to digital "1".

Figure 2 VOX Function

DEN , EXCK, DIN, DOUT

Serial control ports for MCU interface.

Reading and writing data are performed by an external MCU through these pins. Eight registers with eight bits are provided on the devices.

DEN is the “Enable” control signal input, EXCK is the data shift clock input, DIN is the address and data input, and DOUT is the data output.

Fig.3 shows the input/output timing diagram.

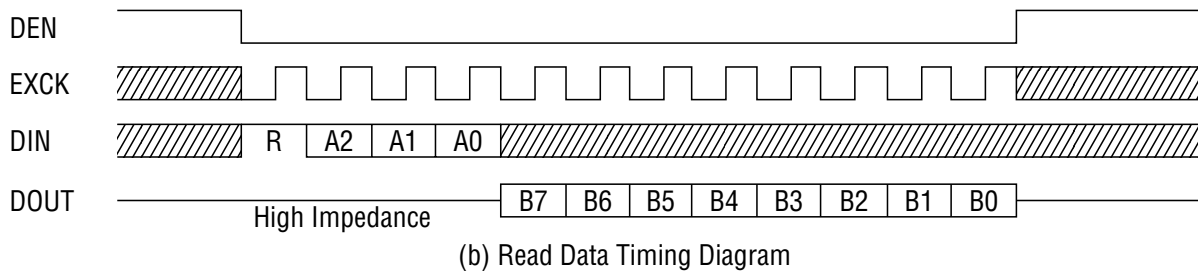
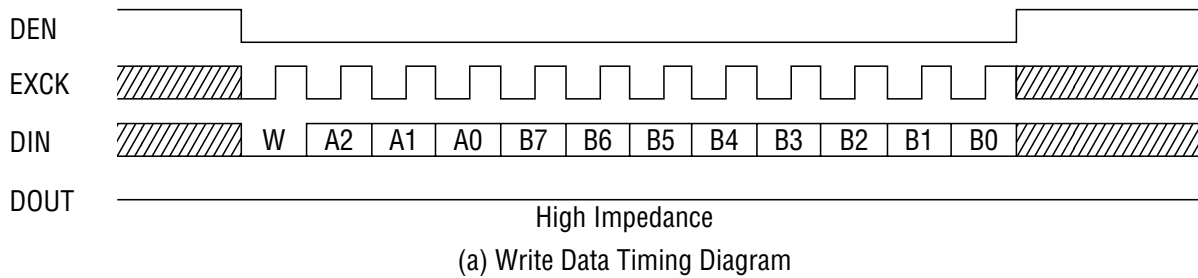

Figure 3 MCU Interface Input/Output Timing

Table 1 shows the register map.

Table-1

| Name | Address | | | Control and Detect Data | | | | | | | | R/W | |
|------|---------|----|----|-------------------------|-----------------|-----------------|-------------|------------|--------------------|---------------|---------------|---------------|-----|
| | A2 | A1 | A0 | B7 | B6 | B5 | B4 | B3 | B2 | B1 | B0 | | |
| CR0 | 0 | 0 | 0 | A/ μ SEL | MCK SEL | PDN ALL | — | — | — | — | — | PDN SAO/AOUT | R/W |
| CR1 | 0 | 0 | 1 | MODE1 | MODE0 | TX RESET | RX RESET | TX MUTE | RX MUTE | — | — | RX PAD | R/W |
| CR2 | 0 | 1 | 0 | TX ON/OFF | TX GAIN2 | TX GAIN1 | TX GAIN0 | RX ON/OFF | RX GAIN2 | RX GAIN1 | RX GAIN0 | RX GAIN0 | R/W |
| CR3 | 0 | 1 | 1 | Side Tone GAIN2 | Side Tone GAIN1 | Side Tone GAIN0 | TONE ON/OFF | TONE GAIN3 | TONE GAIN2 | TONE GAIN1 | TONE GAIN0 | TONE GAIN0 | R/W |
| CR4 | 1 | 0 | 0 | DTMF/OTHERS SEL | TONE SEND | SAO/VFRO | TONE4 | TONE3 | TONE2 | TONE1 | TONE0 | TONE0 | R/W |
| CR5 | 1 | 0 | 1 | — | — | — | — | — | — | — | — | — | R/W |
| CR6 | 1 | 1 | 0 | VOX ON/OFF | ON LVL1 | ON LVL0 | OFF TIME | VOX IN | RX NOISE LEVEL SEL | RX NOISE LVL1 | RX NOISE LVL0 | RX NOISE LVL0 | R/W |
| CR7 | 1 | 1 | 1 | VOX OUT | TX NOISE LVL1 | TX NOISE LVL0 | — | — | — | — | — | — | R |

R/W : Read/Write enable R : Read only register.

ABSOLUTE MAXIMUM RATINGS

| Parameter | Symbol | Condition | Rating | Unit |
|-----------------------|-----------|-----------|------------------------|------|
| Power Supply Voltage | V_{DD} | — | -0.3 to +5 | V |
| Analog Input Voltage | V_{AIN} | — | -0.3 to $V_{DD} + 0.3$ | V |
| Digital Input Voltage | V_{DIN} | — | -0.3 to $V_{DD} + 0.3$ | V |
| Storage Temperature | T_{STG} | — | -55 to +150 | °C |

RECOMMENDED OPERATING CONDITIONS

| Parameter | Symbol | Condition | Min. | Typ. | Max. | Unit |
|-----------------------------------|------------|--|----------------------|--------|----------------------|------|
| Power Supply Voltage | V_{DD} | Voltage must be fixed | 2.7 | — | 3.6 | V |
| Operating Temperature | T_a | — | -25 | +25 | +70 | °C |
| Digital Input High Voltage | V_{IH} | MCK, XSYNC, RSYNC, PCMRI, PCMSI, BCLK, IR, $\overline{PDN/RESET}$, DEN, EXCK, DIN | $0.45 \times V_{DD}$ | — | V_{DD} | V |
| Digital Input Low Voltage | V_{IL} | MCK, XSYNC, RSYNC, PCMRI, PCMSI, BCLK, IR, $\overline{PDN/RESET}$, DEN, EXCK, DIN | 0 | — | $0.16 \times V_{DD}$ | V |
| Master Clock Frequency | f_{MCK1} | MCK (CR0-B6 = "0") | -0.01% | 12.288 | +0.01% | MHz |
| | f_{MCK2} | MCK (CR0-B6 = "1") | -0.01% | 19.200 | +0.01% | MHz |
| Bit Clock Frequency | f_{BCK} | BCLK | 64 | — | 2048 | kHz |
| Synchronous Signal Frequency | f_{SYMC} | XSYNC, RSYNC | — | 8.0 | — | kHz |
| Clock Duty Ratio | D_C | MCK, BCLK, EXCK | 30 | 50 | 70 | % |
| Digital Input Rise Time | t_{ir} | MCK, XSYNC, RSYNC, PCMRI, PCMSI, BCLK, IR, $\overline{PDN/RESET}$, DEN, EXCK, DIN | — | — | 50 | ns |
| Digital Input Fall Time | t_{if} | MCK, XSYNC, RSYNC, PCMRI, PCMSI, BCLK, IR, $\overline{PDN/RESET}$, DEN, EXCK, DIN | — | — | 50 | ns |
| Transmit Sync Signal Setting Time | t_{XS} | BCLK to XSYNC | 100 | — | — | ns |
| | t_{XS} | XSYNC to BCLK | 100 | — | — | ns |
| Receive Sync Signal Setting Time | t_{RS} | BCLK to RSYNC | 100 | — | — | ns |
| | t_{SR} | RSYNC to BCLK | 100 | — | — | ns |
| Synchronous Signal Width | t_{WS} | XSYNC, RSYNC | 1 BCLK | — | 100 | μs |
| PCM, ADPCM Set-up Time | t_{DS} | — | 100 | — | — | ns |
| PCM, ADPCM Hold Time | t_{DH} | — | 100 | — | — | ns |
| Digital Output Load | R_{DL} | IS (Pull-up Resistor) | 500 | — | — | Ω |
| | C_{DL} | IS, PCMSO, PCMRO, VOXO, DOUT | — | — | 100 | pF |
| Bypass Capacitors for SG | C_{SG} | SG to AG | $10 + 0.1$ | — | — | μF |

ELECTRICAL CHARACTERISTICS

DC and Digital Interface Characteristics

($V_{DD} = 2.7\text{ V to }3.6\text{ V}$, $T_a = -25^\circ\text{C to }+70^\circ\text{C}$)

| Parameter | Symbol | Condition | Min. | Typ. | Max. | Unit |
|------------------------|-----------|--|----------------------|------|----------------------|---------------|
| Power Supply Current | I_{DD1} | Operating Mode, No Signal, ($V_{DD} = 3.0\text{ V}$) | — | 7 | 14 | mA |
| | I_{DD2} | Power Down Mode, ($V_{DD} = 3.0\text{ V}$) | — | 0.1 | 0.2 | mA |
| Input High Voltage | V_{IH} | — | $0.45 \times V_{DD}$ | — | V_{DD} | V |
| Input Low Voltage | V_{IL} | — | 0.0 | — | $0.16 \times V_{DD}$ | V |
| Input Leakage Current | I_{IH} | $V_I = V_{DD}$ | — | — | 2.0 | μA |
| | I_{IL} | $V_I = 0\text{ V}$ | — | — | 0.5 | μA |
| Output Low Voltage | V_{OL} | 1 LSTTL, Pull-up: $500\ \Omega$ | 0.0 | 0.2 | 0.4 | V |
| Output Leakage Current | I_O | IS | — | — | 10 | μA |
| Input Capacitance | C_{IN} | — | — | 5 | — | pF |
| Output Resistance | R_{OSG} | SG | — | 25 | 50 | k Ω |
| SG Warm-up Time | T_{SG} | SG \leftrightarrow GND $10 + 0.1\ \mu\text{F}$ (Rise time to 90% of max. level) | — | 700 | — | ns |

Transmit Analog Interface Characteristics

($V_{DD} = 2.7\text{ V to }3.6\text{ V}$, $T_a = -25^\circ\text{C to }+70^\circ\text{C}$)

| Parameter | Symbol | Condition | Min. | Typ. | Max. | Unit |
|-------------------------|------------|--|------|------|-------|------------|
| Input Resistance | R_{INX} | AIN1+, AIN1-, AIN2 | 10 | — | — | M Ω |
| Output Load Resistance | R_{LGX} | GSX1, GSX2 | 20 | — | — | k Ω |
| Output Load Capacitance | C_{LGX} | GSX1, GSX2 | — | — | 100 | pF |
| Output Amplitude | V_{OGX} | GSX1, GSX2, $R_L = 20\ \text{k}\Omega$ | — | — | *1.30 | V_{PP} |
| Input Offset Voltage | V_{OFGX} | Pre-OPAMPs | -20 | — | +20 | mV |

* $-7.7\ \text{dBm}$ ($600\ \Omega$) = $0\ \text{dBm}_0$, $+3.14\ \text{dBm}_0 = 1.30\ V_{PP}$ (A-law)

$-7.7\ \text{dBm}$ ($600\ \Omega$) = $0\ \text{dBm}_0$, $+3.17\ \text{dBm}_0 = 1.30\ V_{PP}$ (μ -law)

Receive Analog Interface Characteristics

($V_{DD} = 2.7\text{ V to }3.6\text{ V}$, $T_a = -25^\circ\text{C to }+70^\circ\text{C}$)

| Parameter | Symbol | Condition | Min. | Typ. | Max. | Unit |
|------------------------|------------|--|------|------|-------|---------------|
| Input Resistance | R_{INPW} | PWI | 10 | — | — | $M\Omega$ |
| Output Load Resistance | R_{LVF} | VFRO | 20 | — | — | $k\Omega$ |
| | R_{LAO} | AOUT+, AOUT-, SAO+, SAO- | 1.2 | — | — | $k\Omega$ |
| Output Capacitance | C_{LVF} | VFRO | — | — | 100 | μF |
| | C_{LAO} | AOUT+, AOUT-, SAO+, SAO- | — | — | 100 | μF |
| Output Voltage Level | V_{OVF} | VFRO, $R_L = 20\text{ k}\Omega$ | — | — | *1.30 | V_{PP} |
| | V_{OAO} | AOUT+, AOUT-, $R_L = 1.2\text{ k}\Omega$ | — | — | *1.30 | V_{PP} |
| | | SAO+, SAO- $Z_L = 350\text{ }\Omega$ + 120 nF(See Fig.1) | — | — | *1.30 | V_{PP} |
| Offset Voltage | V_{OFVF} | VFRO | -100 | — | +100 | mV |
| | V_{OFAO} | AOUT+, AOUT- (GAIN = 0 dB, Power amp only) SAO+, SAO- | -20 | — | +20 | mV |
| Open Loop Gain | G_{DB} | Power amp (0.3 to 3.4 kHz, $Z_L = 350\text{ }\Omega + 120\text{ nF}$)(See Fig.1) | 40 | — | — | dB |

* $-7.7\text{ dBm (}600\text{ }\Omega) = 0\text{ dBm}_0$, $+3.14\text{ dBm}_0 = 1.30\text{ V}_{PP}$ (A-law)
 $-7.7\text{ dBm (}600\text{ }\Omega) = 0\text{ dBm}_0$, $+3.17\text{ dBm}_0 = 1.30\text{ V}_{PP}$ (μ -law)

AC Characteristics

(V_{DD} = 2.7 V to 3.6 V, T_a = -25°C to +70°C)

| Parameter | Symbol | Condition | | | Min. | Typ. | Max. | Unit |
|-------------------------------------|---------------------|-------------|--------------|--------|-----------|------|-------|------|
| | | Freq. (Hz) | Level (dBm0) | Others | | | | |
| Transmit Frequency Response | L _{oss} T1 | 0 to 60 | 0 | — | 25 | — | — | dB |
| | L _{oss} T2 | 300 to 3000 | | | -0.15 | — | +0.20 | dB |
| | L _{oss} T3 | 1020 | | | Reference | | | dB |
| | L _{oss} T4 | 3300 | | | -0.15 | — | +0.80 | dB |
| | L _{oss} T5 | 3400 | | | 0 | — | 0.80 | dB |
| | L _{oss} T6 | 3968.75 | | | 13 | — | — | dB |
| Receive Frequency Response | L _{oss} R1 | 0 to 3000 | 0 | — | -0.15 | — | +0.20 | dB |
| | L _{oss} R2 | 1020 | | | Reference | | | dB |
| | L _{oss} R3 | 3300 | | | -0.15 | — | +0.80 | dB |
| | L _{oss} R4 | 3400 | | | 0 | — | 0.80 | dB |
| | L _{oss} R5 | 3968.75 | | | 13 | — | — | dB |
| Transmit Signal to Distortion Ratio | SD T1 | 1020 | 3 | (*1) | 35 | — | — | dB |
| | SD T2 | | 0 | | 35 | — | — | dB |
| | SD T3 | | -30 | | 35 | — | — | dB |
| | SD T4 | | -40 | | 28 | — | — | dB |
| | SD T5 | | -45 | | 23 | — | — | dB |
| Receive Signal to Distortion Ratio | SD R1 | 1020 | 3 | (*1) | 35 | — | — | dB |
| | SD R2 | | 0 | | 35 | — | — | dB |
| | SD R3 | | -30 | | 35 | — | — | dB |
| | SD R4 | | -40 | | 28 | — | — | dB |
| | SD R5 | | -45 | | 23 | — | — | dB |
| Transmit Gain Tracking | GT T1 | 1020 | 3 | — | -0.2 | — | +0.2 | dB |
| | GT T2 | | -10 | | Reference | | | dB |
| | GT T3 | | -40 | | -0.2 | — | +0.2 | dB |
| | GT T4 | | -50 | | -0.5 | — | +0.5 | dB |
| | GT T5 | | -55 | | -1.2 | — | +1.2 | dB |
| Receive Gain Tracking | GT R1 | 1020 | 3 | — | -0.2 | — | +0.2 | dB |
| | GT R2 | | -10 | | Reference | | | dB |
| | GT R3 | | -40 | | -0.2 | — | +0.2 | dB |
| | GT R4 | | -50 | | -0.5 | — | +0.5 | dB |
| | GT R5 | | -55 | | -1.2 | — | +1.2 | dB |

*1 Use the P-message weighted filter

AC Characteristics (Continued)

(V_{DD} = 2.7 V to 3.6 V, T_a = -25°C to +70°C)

| Parameter | Symbol | Condition | | | Min. | Typ. | Max. | Unit |
|---|---|---------------------------|-------------------------------------|--------------|-----------------|---------------|-------------------------|------------------|
| | | Freq. (Hz) | Level (dBm0) | Others | | | | |
| Idle Channel Noise | N _{IDLT} | — | A _{IN} = SG | (*1) | — | — | -68 (-75.7) | dBmOp (dBmp) |
| | N _{IDLR} | — | — | (*1) (*2) | — | — | -72 (-79.7) | |
| Absolute Signal Amplitude | A _{VT} | 1020 | 0 | GSX2 | 0.285 | 0.320 (*3) | 0.359 | V _{rms} |
| | A _{VR} | | | VFRO | 0.285 | 0.320 (*3) | 0.359 | V _{rms} |
| Power Supply Noise Rejection Ratio | P _{SRRT} | Noise Freq. : 0 to 50 kHz | Noise Level : 50 mV _{PP} | — | 30 | — | — | dB |
| | P _{SRRR} | | | | 30 | — | — | dB |
| Digital Output Delay Time PCM and ADPCM Interface | t _{SDX} | — | 1 LSTTL + 100 pF, Pull-up: 500 Ω | See Fig.4 | 0 | — | 200 | ns |
| | t _{SDR} | | | | 0 | — | 200 | ns |
| | t _{XD1} t _{RD1} | | | | 0 | — | 200 | ns |
| | t _{XD2} t _{RD2} | | | | 0 | — | 200 | ns |
| | t _{XD3} t _{RD3} | | | | 0 | — | 200 | ns |
| | Serial Port Digital Input/Output Setting Time | | | | t _{M1} | — | C _L = 100 pF | See Fig.5 |
| t _{M2} | | 50 | — | — | ns | | | |
| t _{M3} | | 50 | — | — | ns | | | |
| t _{M4} | | 50 | — | — | ns | | | |
| t _{M5} | | 100 | — | — | ns | | | |
| t _{M6} | | 50 | — | — | ns | | | |
| t _{M7} | | 50 | — | — | ns | | | |
| t _{M8} | | 0 | — | 50 | ns | | | |
| t _{M9} | | 50 | — | — | ns | | | |
| t _{M10} | | 50 | — | — | ns | | | |
| t _{M11} | | 0 | — | 50 | ns | | | |
| Shift Clock Frequency | f _{EXCK} | — | — | EXCK | — | — | 10 | MHz |

*1 Use the P-message weighted filter
 *2 PCMRI input code "11010101"(A-law)
 "11111111"(μ-law)
 *3 0.320 V_{rms} = 0 dBm0 = -7.7 dBm

Note: All ADPCM coder and decoder characteristics comply with ITU-T Recommendation G.726.

AC Characteristics (DTMF and Other Tones)

(V_{DD} = 2.7 V to 3.6 V, T_a = -25°C to +70°C)

| Parameter | Symbol | Condition | | Min. | Typ. | Max. | Unit |
|---|-------------------|---|--------------------------------|------|------|------|------|
| Frequency Difference | D _{FT1} | DTMF Tones | | -7 | — | +7 | Hz |
| | D _{FT2} | Other Tones | | -7 | — | +7 | Hz |
| Original (reference) Tone Signal Level *4 | V _{TL} | Transmit Tones (Gain setting 0dB) | DTMF (Low) | -18 | -16 | -14 | dBm0 |
| | V _{TH} | | DTMF (High) and Other Tones | -16 | -14 | -12 | dBm0 |
| | V _{RL} | Receive Tones (Tone generator gain setting -6dB) | DTMF (Low) | -10 | -8 | -6 | dBm0 |
| | V _{RH} | | DTMF (High) and Other Tones | -8 | -6 | -4 | dBm0 |
| Relative Level of DTMF Tones | R _{DTMF} | V _{TH} /V _{TL} , V _{RH} /V _{RL} | | 1 | 2 | 3 | dBm0 |

*4 Does not contain the setting value set for the programmable gain

AC Characteristics (Programmable Gain Stages)

(V_{DD} = 2.7 V to 3.6 V, T_a = -25°C to +70°C)

| Parameter | Symbol | Condition | Min. | Typ. | Max. | Unit |
|---------------|----------------|--------------------------------------|------|------|------|------|
| Gain Accuracy | D _G | All gain stages, to programmed value | -1 | 0 | +1 | dB |

AC Characteristics (VOX Function)

(V_{DD} = 2.7 V to 3.6 V, T_a = -25°C to +70°C)

| Parameter | Symbol | Condition | | Min. | Typ. | Max. | Unit |
|---|-------------------|----------------------------|-----------|---------|---------|---------|------|
| Transmit VOX Detect Time (Voice Signal ON/OFF Detect Time) | t _{VXON} | OFF → ON | VOX0, | — | 10 *5 | — | ms |
| | t _{VXOF} | ON → OFF | See Fig.2 | 150/310 | 160/320 | 170/330 | ms |
| Transmit VOX Detect Level Accuracy (Threshold Level) | D _{VX} | To the values (CR6-B6, B5) | | -2.5 | 0 | +2.5 | dB |

*5 When single tone is input at 1000Hz

TIMING DIAGRAM

Transmit Side PCM/ADPCM Data Interface

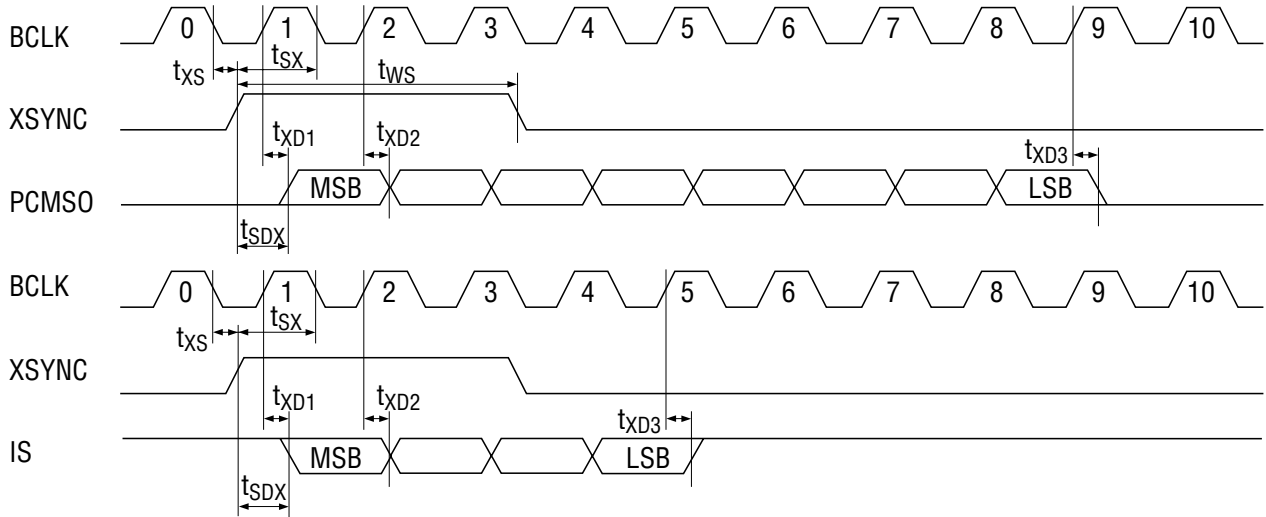

Receive Side PCM/ADPCM Data Interface

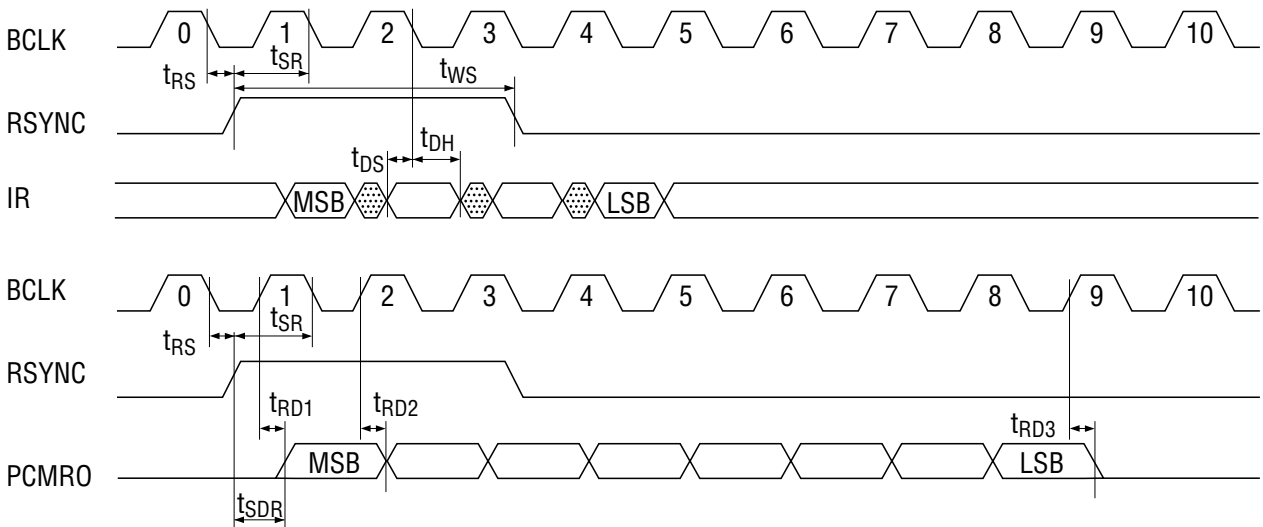

Figure 4 PCM/ADPCM Data Interface

Serial Port Data Transfer for MCU Interface

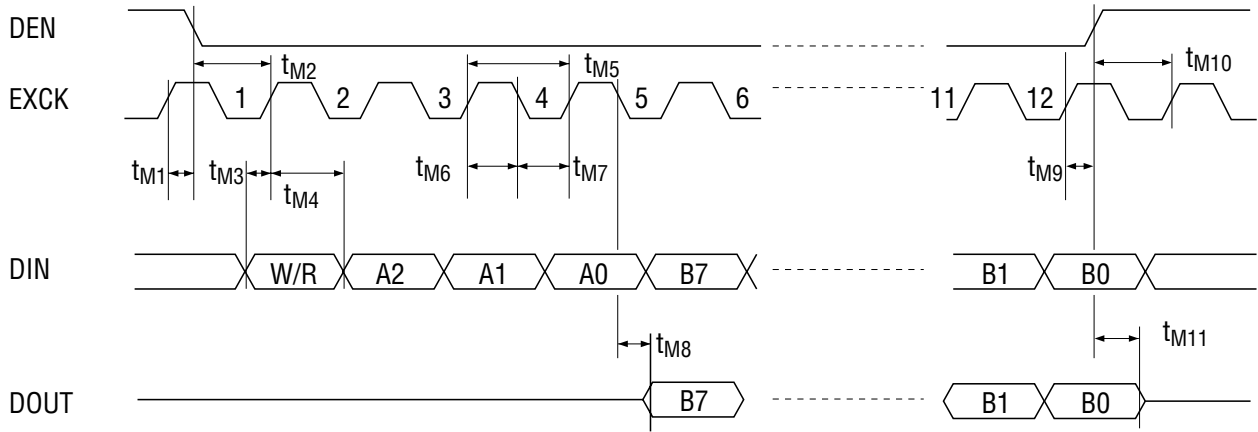

Figure 5 MCU Interface

FUNCTIONAL DESCRIPTION

Control Registers

(1) CR0 (Basic operating mode)

| | B7 | B6 | B5 | B4 | B3 | B2 | B1 | B0 |
|----------------------|--------------|-----------|-----------|-----------|-----------|-----------|-----------|-----------------|
| CR0 | A/ μ SEL | MCK SEL | PDN ALL | — | — | — | — | PDN SAO/AOUT |
| Initial Value (Note) | 0 | 0 | 0 | 0 | 0 | 0 | 0 | 0 |

Note: Initial Value: Reset state by $\overline{\text{PDN/RESET}}$

B7 ...PCM Companding law select; 0/ μ -law, 1/A-law

B6 ...Master clock frequency select; 0/12.288 MHz, 1/19.200 MHz

B5 ...Power down (entire system); 0/Power on, 1/Power down

When using this data for power down control, set pin $\overline{\text{PDN/RESET}}$ at "1" level.

The control registers are not reset by this signal.

B2 ...Not used

B1 ...Not used

B0 ...Power Down for Sound output amps: (SAO+, SAO-), or Receiver output amp (AOUT+, AOUT-, VFRO);

If this data is set to digital "1", either a pair of sound amplifiers or a pair of receiver amplifiers enters the power down state depending on the set data on CR4-B5.

If this data is set to digital "0", sound amplifiers and receiver amplifiers are in the power-on state.

B4, B3 ...Not used (These pins are used to test the device. They should be set to "0" during normal operation.)

(2) CR1 (ADPCM block operating mode)

| | B7 | B6 | B5 | B4 | B3 | B2 | B1 | B0 |
|---------------|-----------|-----------|-----------|-----------|-----------|-----------|-----------|-----------|
| CR1 | MODE1 | MODE0 | TX RESET | RX RESET | TX MUTE | RX MUTE | — | RX PAD |
| Initial Value | 0 | 0 | 0 | 0 | 0 | 0 | 0 | 0 |

B7, B6 ... ADPCM data compression algorithm select;

- (0, 0): 32 kbps
- (0, 1): 64 kbps (data through)
- (1, 0): 24 kbps
- (1, 1): 16 kbps

B5 ... ADPCM of transmit reset (specified by G.726);

1/Reset*

B4 ... ADPCM of receive reset (specified by G.726);

1/Reset*

B3 ... ADPCM transmit data mute,

1/Mute

B2 ... ADPCM receive data mute,

1/Mute

B1 ... Not used

B0 ... Receive side PAD,

1/inserted,12 dB loss
0/no PAD

* The reset width should be 125µs or more.
The transmitter and receiver cannot be reset separately.
They must be reset at the same time.

(3) CR2 (PCM CODEC operational mode setting and transmit/receive gain adjustment)

| | B7 | B6 | B5 | B4 | B3 | B2 | B1 | B0 |
|---------------|-----------|-----------|-----------|-----------|-----------|-----------|-----------|-----------|
| CR2 | TX ON/OFF | TX GAIN2 | TX GAIN1 | TX GAIN0 | RX ON/OFF | RX GAIN2 | RX GAIN1 | RX GAIN0 |
| Initial Value | 0 | 0 | 0 | 0 | 0 | 0 | 0 | 0 |

B7 ... PCM Coder disable; 0/Enable, 1/Disable (transmit PCM idle pattern)

B6, B5, B4 ... Transmit gain adjustment, refer to Table-2.

B3 ... PCM Decoder disable; 0/Enable, 1/Disable (receive PCM idle pattern)

B2, B1, B0 ... Receive gain setting, refer to Table-2.

Table-2

| B6 | B5 | B4 | Transmit Gain | B2 | B1 | B0 | Receive Gain |
|-----------|-----------|-----------|----------------------|-----------|-----------|-----------|---------------------|
| 0 | 0 | 0 | -6 dB | 0 | 0 | 0 | -6 dB |
| 0 | 0 | 1 | -4 dB | 0 | 0 | 1 | -4 dB |
| 0 | 1 | 0 | -2 dB | 0 | 1 | 0 | -2 dB |
| 0 | 1 | 1 | 0 dB | 0 | 1 | 1 | 0 dB |
| 1 | 0 | 0 | +2 dB | 1 | 0 | 0 | +2 dB |
| 1 | 0 | 1 | +4 dB | 1 | 0 | 1 | +4 dB |
| 1 | 1 | 0 | +6 dB | 1 | 1 | 0 | +6 dB |
| 1 | 1 | 1 | +8 dB | 1 | 1 | 1 | +8 dB |

This programmable gain table, not only for transmit/receive voice signal and the transmitted DTMF and other tones. The transmission of these tone signal is enabled by the CR4-B6 data described later. The original (reference) signal amplitude of these tones is analogically defined as follows.

- DTMF low-group-tones -16 dBm0
- DTMF high-group-tones and others -14 dBm0

For example, when selecting +8 dB (B6, B5, B4) = (1,1,1) as a transmit gain, each tone signal amplitude with an analogical expression on the pin PCMSO becomes as follows .

- DTMF low-group tones -8 dBm0
- DTMF high-group tones and other tones -6 dBm0

Gain setting for the side tone (path to receive side from transmit side) and the receive side tone is performed by register CR3.

(4) CR3 (Side tone and other tone generator gain setting)

| | B7 | B6 | B5 | B4 | B3 | B2 | B1 | B0 |
|---------------|---------------------|---------------------|---------------------|----------------|---------------|---------------|---------------|---------------|
| CR3 | Side. Tone GAIN2 | Side. Tone GAIN1 | Side. Tone GAIN0 | TONE ON/OFF | TONE GAIN3 | TONE GAIN2 | TONE GAIN1 | TONE GAIN0 |
| Initial Value | 0 | 0 | 0 | 0 | 0 | 0 | 0 | 0 |

B7, B6, B5 ... Side tone path gain setting, refer to Table-3.

B4 ... Tone generator enable; 0/Disable, 1/Enable

B3, B2, B1, B0 ... Tone generator gain adjustment for receive side, refer to Table-4

Table-3

| B7 | B6 | B5 | Side Tone Path Gain |
|-----------|-----------|-----------|----------------------------|
| 0 | 0 | 0 | OFF |
| 0 | 0 | 1 | -21 dB |
| 0 | 1 | 0 | -19 dB |
| 0 | 1 | 1 | -17 dB |
| 1 | 0 | 0 | -15 dB |
| 1 | 0 | 1 | -13 dB |
| 1 | 1 | 0 | -11 dB |
| 1 | 1 | 1 | -9 dB |

Table-4

| B3 | B2 | B1 | B0 | Tone Generator Gain | B3 | B2 | B1 | B0 | Tone Generator Gain |
|-----------|-----------|-----------|-----------|----------------------------|-----------|-----------|-----------|-----------|----------------------------|
| 0 | 0 | 0 | 0 | -36 dB | 1 | 0 | 0 | 0 | -20 dB |
| 0 | 0 | 0 | 1 | -34 dB | 1 | 0 | 0 | 1 | -18 dB |
| 0 | 0 | 1 | 0 | -32 dB | 1 | 0 | 1 | 0 | -16 dB |
| 0 | 0 | 1 | 1 | -30 dB | 1 | 0 | 1 | 1 | -14 dB |
| 0 | 1 | 0 | 0 | -28 dB | 1 | 1 | 0 | 0 | -12 dB |
| 0 | 1 | 0 | 1 | -26 dB | 1 | 1 | 0 | 1 | -10 dB |
| 0 | 1 | 1 | 0 | -24 dB | 1 | 1 | 1 | 0 | -8 dB |
| 0 | 1 | 1 | 1 | -22 dB | 1 | 1 | 1 | 1 | -6 dB |

The tone generator gain setting table for the receive side, as shown in Table-4, depends upon the following reference level.

- DTMF low-group tones -2 dBm0
- DTMF high-group tones and others 0 dBm0

For example, when selecting -6 dB (B3, B2, B1, B0) = (1, 1, 1, 1) as a tone generator gain, each DTMF tone signal amplitude on SAO+/SAO- or VFRO is as follows.

- DTMF low-group tone -8 dBm0
- DTMF high-group tone or other tones -6 dBm0

(5) CR4 (Tone generator operating mode and frequency select)

| | B7 | B6 | B5 | B4 | B3 | B2 | B1 | B0 |
|---------------|--------------------|--------------|--------------|-----------|-----------|-----------|-----------|-----------|
| CR4 | DTMF/OTHERS SEL | TONE SEND | SAO/ VFRO | TONE4 | TONE3 | TONE2 | TONE1 | TONE0 |
| Initial Value | 0 | 0 | 0 | 0 | 0 | 0 | 0 | 0 |

B7 ... DTMF or other tones select; 0/Others, 1/DTMF

B6 ... Tone transmit enable (Transmit side); 0/Voice signal (transmit), 1/Tone transmit

B5 ... Tone output pin select (Receive side); 0/VFRO, 1/SAO+ and SAO-

B4, B3, B2, B1, B0 ... Tone frequency setting, referred to Table-5-1, 5-2, and 5-3.

(a) B7 = 1 (DTMF tone)

Table-5-1

| B4 | B3 | B2 | B1 | B0 | Frequency | B4 | B3 | B2 | B1 | B0 | Frequency |
|-----------|-----------|-----------|-----------|-----------|------------------|-----------|-----------|-----------|-----------|-----------|------------------|
| * | 0 | 0 | 0 | 0 | 697 Hz + 1209 Hz | * | 1 | 0 | 0 | 0 | 852 Hz + 1209 Hz |
| * | 0 | 0 | 0 | 1 | 697 Hz + 1336 Hz | * | 1 | 0 | 0 | 1 | 852 Hz + 1336 Hz |
| * | 0 | 0 | 1 | 0 | 697 Hz + 1477 Hz | * | 1 | 0 | 1 | 0 | 852 Hz + 1477 Hz |
| * | 0 | 0 | 1 | 1 | 697 Hz + 1633 Hz | * | 1 | 0 | 1 | 1 | 852 Hz + 1633 Hz |
| * | 0 | 1 | 0 | 0 | 770 Hz + 1209 Hz | * | 1 | 1 | 0 | 0 | 941 Hz + 1209 Hz |
| * | 0 | 1 | 0 | 1 | 770 Hz + 1336 Hz | * | 1 | 1 | 0 | 1 | 941 Hz + 1336 Hz |
| * | 0 | 1 | 1 | 0 | 770 Hz + 1477 Hz | * | 1 | 1 | 1 | 0 | 941 Hz + 1477 Hz |
| * | 0 | 1 | 1 | 1 | 770 Hz + 1633 Hz | * | 1 | 1 | 1 | 1 | 941 Hz + 1633 Hz |

*Unrelated

(b) B7 = 0 (Other tones)

<MSM7570L-01>

Table-5-2

| B4 | B3 | B2 | B1 | B0 | Frequency | B4 | B3 | B2 | B1 | B0 | Frequency |
|-----------|-----------|-----------|-----------|-----------|-------------------------|-----------|-----------|-----------|-----------|-----------|---------------------|
| 0 | 0 | 0 | 0 | 0 | 1k/1333 Hz, 16 Hz wamb. | 1 | 0 | 0 | 0 | 0 | 2000 Hz Single tone |
| 0 | 0 | 0 | 0 | 1 | 800/667 Hz, 16 Hz wamb. | 1 | 0 | 0 | 0 | 1 | 2042 Hz Single tone |
| 0 | 0 | 0 | 1 | 0 | 800/1k Hz, 16 Hz wamb. | 1 | 0 | 0 | 1 | 0 | 2514 Hz Single tone |
| 0 | 0 | 0 | 1 | 1 | 500/667 Hz, 16 Hz wamb. | 1 | 0 | 0 | 1 | 1 | 500 Hz Single tone |
| 0 | 0 | 1 | 0 | 0 | 500/400 Hz, 16 Hz wamb. | 1 | 0 | 1 | 0 | 0 | 667 Hz Single tone |
| 0 | 0 | 1 | 0 | 1 | 800/1k Hz, 8 Hz wamb. | 1 | 0 | 1 | 0 | 1 | 1333 Hz Single tone |
| 0 | 0 | 1 | 1 | 0 | 500/400 Hz, 8 Hz wamb. | 1 | 0 | 1 | 1 | 0 | 2100 Hz Single tone |
| 0 | 0 | 1 | 1 | 1 | 400 Hz, 16 Hz wamb. | 1 | 0 | 1 | 1 | 1 | — |
| 0 | 1 | 0 | 0 | 0 | 400 Hz, 20 Hz wamb. | 1 | 1 | 0 | 0 | 0 | — |
| 0 | 1 | 0 | 0 | 1 | 400 Hz Single tone | 1 | 1 | 0 | 0 | 1 | — |
| 0 | 1 | 0 | 1 | 0 | 425 Hz Single tone | 1 | 1 | 0 | 1 | 0 | — |
| 0 | 1 | 0 | 1 | 1 | 440 Hz Single tone | 1 | 1 | 0 | 1 | 1 | — |
| 0 | 1 | 1 | 0 | 0 | 450 Hz Single tone | 1 | 1 | 1 | 0 | 0 | — |
| 0 | 1 | 1 | 0 | 1 | 800 Hz Single tone | 1 | 1 | 1 | 0 | 1 | — |
| 0 | 1 | 1 | 1 | 0 | 1000 Hz Single tone | 1 | 1 | 1 | 1 | 0 | — |
| 0 | 1 | 1 | 1 | 1 | 1300 Hz Single tone | 1 | 1 | 1 | 1 | 1 | — |

(b) B7 = 0 (Other tones)
 <MSM7570L-02>

Table-5-3

| B4 | B3 | B2 | B1 | B0 | Frequency | B4 | B3 | B2 | B1 | B0 | Frequency |
|----|----|----|----|----|------------------------|----|----|----|----|----|---------------------|
| 0 | 0 | 0 | 0 | 0 | 1k/1333 Hz 16 Hz wamb. | 1 | 0 | 0 | 0 | 0 | 2500 Hz Single tone |
| 0 | 0 | 0 | 0 | 1 | 800/1k Hz 16 Hz wamb. | 1 | 0 | 0 | 0 | 1 | 2600 Hz Single tone |
| 0 | 0 | 0 | 1 | 0 | 800/1k Hz 8 Hz wamb. | 1 | 0 | 0 | 1 | 0 | 2670 Hz Single tone |
| 0 | 0 | 0 | 1 | 1 | 400 Hz, 16 Hz wamb. | 1 | 0 | 0 | 1 | 1 | 2700 Hz Single tone |
| 0 | 0 | 1 | 0 | 0 | 2700 Hz, 16 Hz wamb. | 1 | 0 | 1 | 0 | 0 | 2800 Hz Single tone |
| 0 | 0 | 1 | 0 | 1 | 400 Hz | 1 | 0 | 1 | 0 | 1 | 2910 Hz Single tone |
| 0 | 0 | 1 | 1 | 0 | 800 Hz | 1 | 0 | 1 | 1 | 0 | 3000 Hz Single tone |
| 0 | 0 | 1 | 1 | 1 | 1000 Hz | 1 | 0 | 1 | 1 | 1 | 3110 Hz Single tone |
| 0 | 1 | 0 | 0 | 0 | 1333 Hz | 1 | 1 | 0 | 0 | 0 | 3200 Hz Single tone |
| 0 | 1 | 0 | 0 | 1 | 1440 Hz | 1 | 1 | 0 | 0 | 1 | — |
| 0 | 1 | 0 | 1 | 0 | 1900 Hz | 1 | 1 | 0 | 1 | 0 | — |
| 0 | 1 | 0 | 1 | 1 | 2000 Hz | 1 | 1 | 0 | 1 | 1 | — |
| 0 | 1 | 1 | 0 | 0 | 2100 Hz | 1 | 1 | 1 | 0 | 0 | — |
| 0 | 1 | 1 | 0 | 1 | 2180 Hz | 1 | 1 | 1 | 0 | 1 | — |
| 0 | 1 | 1 | 1 | 0 | 2300 Hz | 1 | 1 | 1 | 1 | 0 | — |
| 0 | 1 | 1 | 1 | 1 | 2400 Hz | 1 | 1 | 1 | 1 | 1 | — |

(6) CR5 (Not used)

| | B7 | B6 | B5 | B4 | B3 | B2 | B1 | B0 |
|---------------|----|----|----|----|----|----|----|----|
| CR5 | — | — | — | — | — | — | — | — |
| Initial Value | 0 | 0 | 0 | 0 | 0 | 0 | 0 | 0 |

B7 – B0..... Not used

(7) CR6 (VOX function control)

| | B7 | B6 | B5 | B4 | B3 | B2 | B1 | B0 |
|---------------|---------------|------------|------------|-------------|-----------|-----------------------|------------------|------------------|
| CR6 | VOX ON/OFF | ON LVL1 | ON LVL0 | OFF TIME | VOX IN | RX NOISE LEVEL SEL | RX NOISE LVL1 | RX NOISE LVL0 |
| Initial Value | 0 | 0 | 0 | 0 | 0 | 0 | 0 | 0 |

B7 ... VOX function enable; 0/Disable, 1/Enable

B6, B5 ... Transmit signal energy detect (Transmit VOX) threshold

(0, 0): -30 dBm0

(0, 1): -35 dBm0

(1, 0): -40 dBm0

(1, 1): -45 dBm0

B4 ... Hang-over time (Fig.2, T_{VXOFF}); 0/160 ms, 1/320 ms

B3 ... Receive VOX function setting; 0/Background noise transmit, 1/Voice signal detect

When using this data for control, set pin VOXI at "0" level.

B2 ... Background noise amplitude setting; 0/Automatic, 1/Programmable by B1 and B0

Automatic : Set the noise at the voice signal amplitude when B3 (or VOXI) changes from "1" to digital "0".

B1, B0 ... (0, 0): No noise

(0, 1): -55 dBm0

(1, 0): -45 dBm0

(1, 1): -35 dBm0

(8) CR7 (Detect register, read only)

| | B7 | B6 | B5 | B4 | B3 | B2 | B1 | B0 |
|---------------|------------|------------------|------------------|-----------|-----------|-----------|-----------|-----------|
| CR7 | VOX OUT | TX NOISE LVL1 | TX NOISE LVL0 | — | — | — | — | — |
| Initial Value | 0 | 0 | 0 | * | * | * | * | * |

* For IC test

B7 ... Transmit VOX function result; 0/Silence, 1/Voice

B6, B5 ... Transmit silence level (indicator); (at 1000 Hz)

(0, 0) : Below -60 dBm0

(0, 1) : -50 to -60 dBm0

(1, 0) : -40 to -50 dBm0

(1, 1) : Above -40 dBm0

Note: These outputs are valid only when the VOX function is enabled by CR6-B7.

B4 ... Not used

B3 ... Not used

B2 ... Not used

B1 ... Not used

B0 ... Not used

APPLICATION CIRCUIT

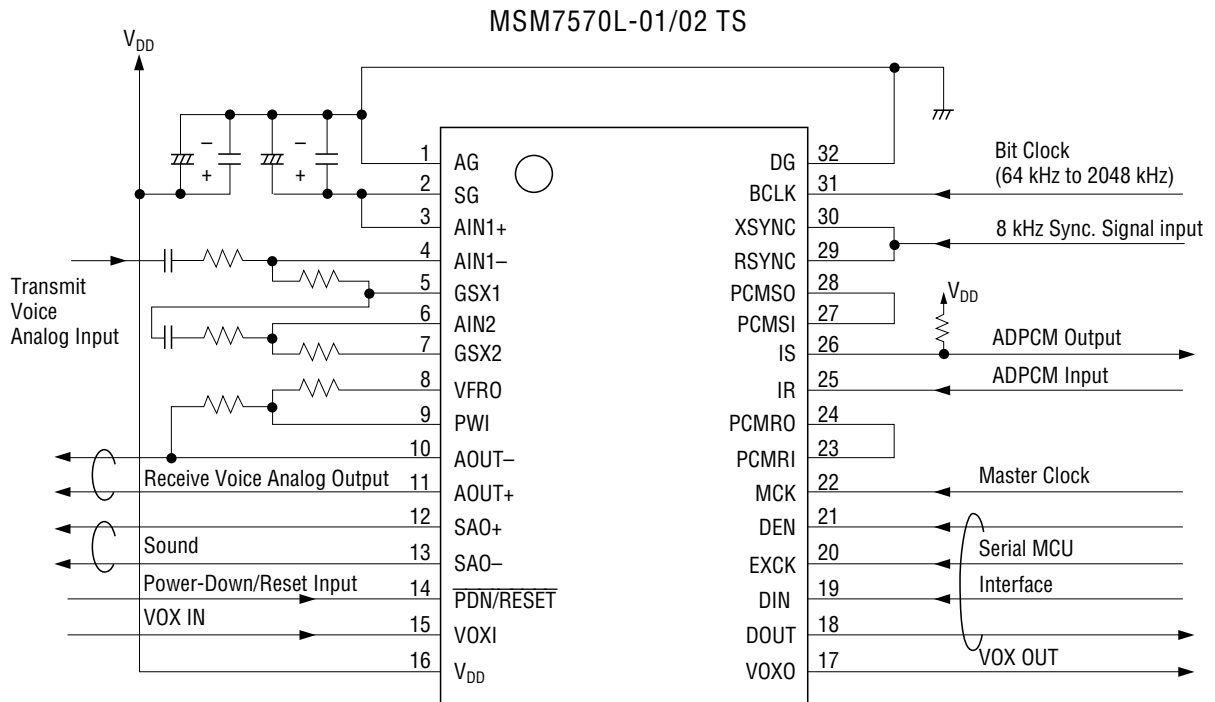

* Single-ended Analog Input Stage Type

PACKAGE DIMENSIONS

(Unit : mm)

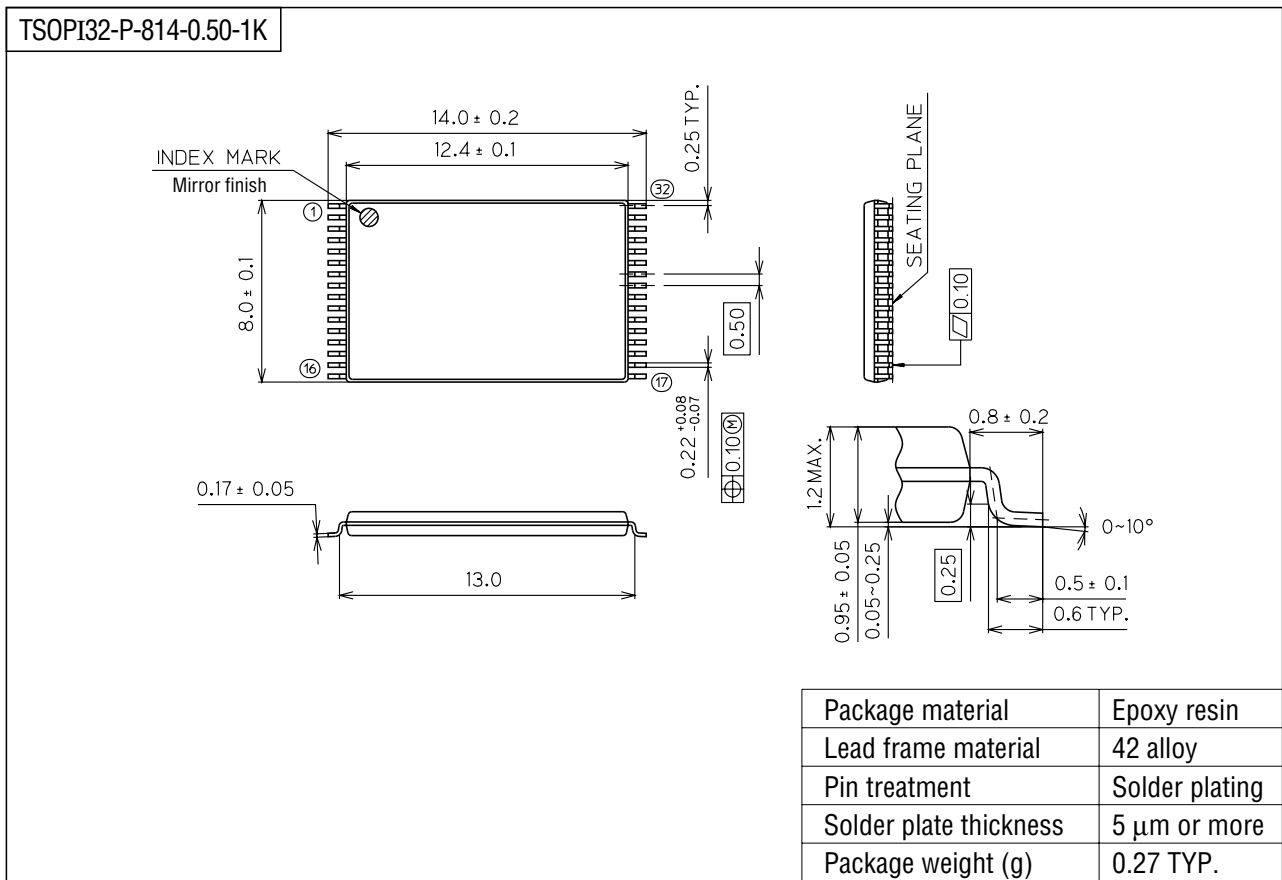

Notes for Mounting the Surface Mount Type Package

The SOP, QFP, TSOP, SOJ, QFJ (PLCC), SHP and BGA are surface mount type packages, which are very susceptible to heat in reflow mounting and humidity absorbed in storage. Therefore, before you perform reflow mounting, contact Oki's responsible sales person for the product name, package name, pin number, package code and desired mounting conditions (reflow method, temperature and times).