

# OKI electronic components

## OL5204N-50/P

### 1.55 $\mu\text{m}$ High-Power DIP Module with 9mm Profile

#### GENERAL DESCRIPTION

The OL5204N-50/P is a 1.55  $\mu\text{m}$  high-power laser in a 14-pin DIL package with 9mm profile. Having extreme high-power in pulsed condition, this device can be used in an optical measurement equipment like OTDR systems.

#### FEATURES

- Fiber output power:  $P_f=50$  mW (pulse width 10  $\mu\text{s}$ , duty ratio 1 %)
- Cooled DIL Package, 9mm high

#### APPLICATIONS

- Optical measurement equipment
- OTDR

#### PACKAGE DIMENSIONS (Unit: mm)

- OL5204N-50/P

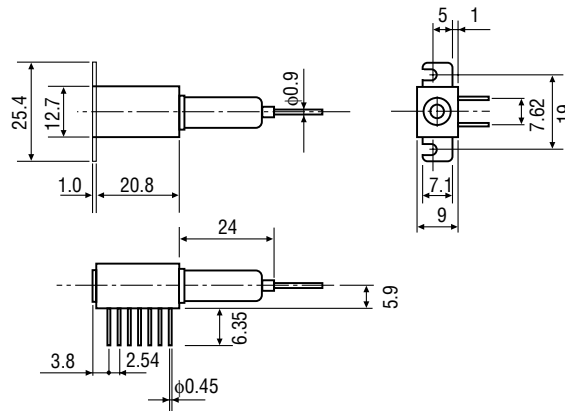

TERMINAL CONNECTION  
(BOTTOM VIEW)

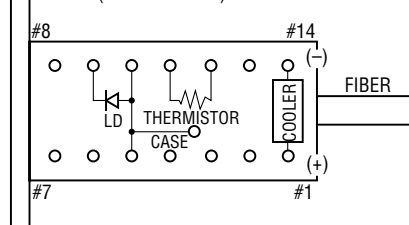

PIN No.	FUNCTION	PIN No.	FUNCTION
1	COOLER ANODE	8	NC
2	NC	9	LD CATHODE
3	NC	10	LD ANODE and CASE GROUND
4	NC	11	THERMISTOR
5	LD ANODE and CASE GROUND	12	THERMISTOR
6	NC	13	NC
7	NC	14	COOLER CATHODE

**ABSOLUTE MAXIMUM RATINGS**

Parameter	Symbol	Test Conditions	Ratings	Unit
Fiber Output Power	Pf	Ta=25°C	60*	mW
LD Reverse Voltage	V <sub>R</sub> (LD)		2	V
LD Forward Current	I <sub>F</sub> (LD)		800*	mA
Cooler Current	I <sub>c</sub>		1.2	A
Operating Temperature	T <sub>opr</sub>	—	-20 to +65	°C
Storage Temperature	T <sub>stg</sub>	—	-40 to +70	°C

\*Pulse width less than 10 μs, duty ratio less than 1 %

**OPTICAL AND ELECTRICAL CHARACTERISTICS**

(T<sub>LD</sub>=25°C, 10 μs Pulse Width and 1 % Duty ratio)

Parameter	Symbol	Test Conditions	Min.	Typ.	Max.	Unit
Threshold Current	I <sub>th</sub>	—	—	20	50	mA
Fiber Output Power	Pf	I <sub>F</sub> =750 mA	50	—	—	mW
Center Wavelength	λ <sub>c</sub>	Pf=50 mW	1530	1550	1580	nm
Spectral Width	σ	Pf=50 mW, RMS×1	—	—	10	nm
Forward Voltage	V <sub>F</sub>	Pf=50 mW	—	1.7	3	V
Cooler Capacity	ΔT	50 mW	40	—	—	°C
Cooler Current	I <sub>c</sub>	ΔT=40°C, Pf=50mW	—	—	1	A
Cooler Voltage	V <sub>c</sub>	ΔT=40°C, Pf=50mW	—	—	2	V
Thermistor Resistance	R <sub>th</sub>	—	—	10	—	kΩ

**FIBER PIGTAIL SPECIFICATIONS**

Parameter	Specifications	Unit
Fiber Type	Single-mode	—
Mode Field Diameter	10±1	μm
Cladding Diameter	125±2	μm
Jacket Diameter	900	μm
Length	1 (Min.)	m
Connector	FC	—

TYPICAL CHARACTERISTICS

Fiber Output Power vs. Forward Current

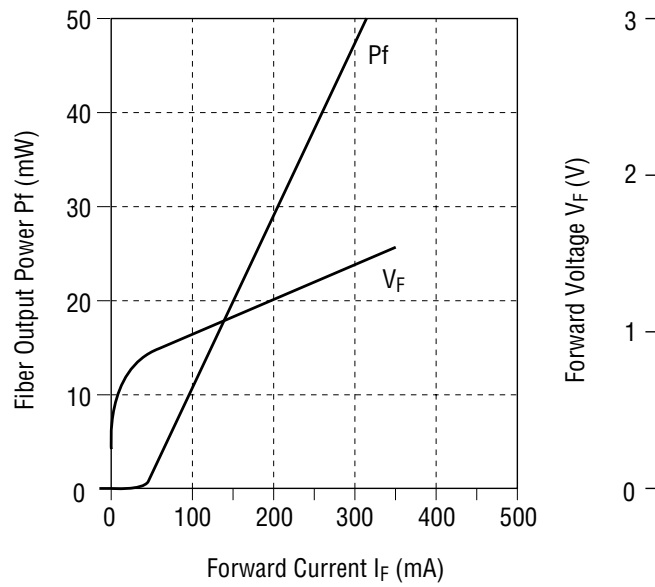

Oscillation Spectrum

