

(COTS) COMMERCIAL OFF-THE-SHELF FIXED
VOLTAGE NEGATIVE REGULATORS IN TO-257

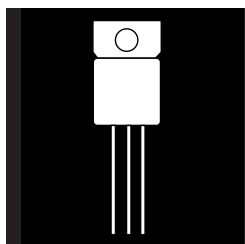

Three Terminal, Fixed Voltage, 1.5 Amp
Precision Negative Regulators In Hermetic
JEDEC TO-257AA Package

FEATURES

- Isolated Hermetic Package, JEDEC TO-257AA Outline
- Output Voltages: -5V, -12V, -15V
- Output Voltages Set Internally To $\pm 2\%$
- Built-In Thermal Overload Protection
- Short Circuit Current Limiting
- Standard Off-The-Shelf

DESCRIPTION

These three terminal negative regulators are supplied in a hermetically sealed metal package whose outline is similar to the industry standard TO-220 plastic package. All protective features are designed into the circuit, including thermal shutdown, current limiting and safe-area control. With heat sinking, they can deliver over 1.5 amps of output current. These units feature internally trimmed output voltages to 2% of nominal voltage. Standard voltages are -5V, -12V, and -15V. However, other voltages are available up to -24 volts. These units are ideally suited for Military applications where a hermetically sealed package is required.

ABSOLUTE MAXIMUM RATINGS @ 25°C

Input Voltage	-35 V
Operating Junction Temperature Range	- 55°C to + 150°C
Storage Temperature Range	- 65°C to + 150°C
Typical Power/Thermal Characteristics:	
Rated Power @ 25° C	T_C 17.5W
	T_A 3 W
Thermal Resistance	
	θ_{JC} 4.2°C/W
	θ_{JA} 42°C/W

COM7900T Series

ELECTRICAL CHARACTERISTICS -5 V_{OUT} V_{IN} = -10V, I_O = 500mA, -55°C T_A 125°C (unless otherwise specified)

Parameter	Symbol	Test Conditions	Min.	Max.	Unit
Output Voltage	V _{OUT}	T _A = 25°C	-4.9	-5.1	V
		V _{IN} = -7.5V to -20V	• -4.8	-5.2	V
Line Regulation (Ntte 1)	V _{RLINE}	V _{IN} = -7.5V to -20V		12	mV
				25	mV
		V _{IN} = -8.0V to -12V		5	mV
Load Regulation (Ntte 1)	V _{RLOAD}	I _B = 5mA to 1.5 Amp		20	mV
				25	mV
		I _B = 250mA to 750 mA		15	mV
Standby Current Drain	I _{SCD}			2.5	mA
				3.0	mA
Standby Current Drain Change With Line	D I _{SCD} (Line)	V _{IN} = -7.0V to -20V	•	0.4	mA
Standby Current Drain Change With Load	D I _{SCD} (Load)	I _B = 5mA to 1000mA	•	0.4	mA
Dropout Voltage	V _{DRO}	DV _{OUT} = 100mV, I _O = 1.0A	•	2.5	V
Peak Output Current	I _{B (pk)}	T _A = 25°C	1.5	3.3	A
Short Circuit Current (Ntte 2)	I _{SS}	V _{IN} = -35V	•	1.2	A
Ripple Rejection	DV _{IN} DV _{OUT}	f =120 Hz, DV _{IN} = -10V	63		dB
		(Ntte 3)	• 60		dB
Output Noise Voltage (Ntte 3)	N _O	T _A = 25°C, f =10 Hz to 100kHz		40	µV/V RMS
Long Term Stability (Ntte 3)	DV _{OUT} Dt	T _A = 25°C, t = 1000 hrs.		75	mV

ELECTRICAL CHARACTERISTICS -12 V_{OUT} V_{IN} = -19V, I_O = 500mA, -55°C T_A 125°C (unless otherwise specified)

Parameter	Symbol	Test Conditions	Min.	Max.	Unit
Output Voltage	V _{OUT}	T _A = 25°C	-11.76	-12.24	V
		V _{IN} = -14.5V to -21V	• -11.6	-12.4	V
Line Regulation (Ntte 1)	V _{RLINE}	V _{IN} = -14.5V to -21V		20	mV
				50	mV
		V _{IN} = -16V to -22V		10	mV
Load Regulation (Ntte 1)	V _{RLOAD}	I _B = 5mA to 1.5 Amp		32	mV
				60	mV
		I _B = 250mA to 750 mA		16	mV
Standby Current Drain	I _{SCD}			3.5	mA
				4.0	mA
Standby Current Drain Change With Line	D I _{SCD} (Line)	V _{IN} = -14.5V to -21V	•	0.8	mA
Standby Current Drain Change With Load	D I _{SCD} (Load)	I _B = 5mA to 1000mA	•	0.5	mA
Dropout Voltage	V _{DRO}	DV _{OUT} = 100mV, I _O = 1.0A	•	1.8	V
Peak Output Current	I _{B (pk)}	T _A = 25°C, I _O = 5mA to 1A	1.5	3.3	A
Short Circuit Current (Ntte 2)	I _{SS}	V _{IN} = -35V	•	1.2	A
Ripple Rejection	DV _{IN} DV _{OUT}	f =120 Hz, DV _{IN} = -10V	56		dB
		(Ntte 3)	• 53		dB
Output Noise Voltage (Ntte 3)	N _O	T _A = 25°C, f =10 Hz to 100kHz		40	µV/V RMS
Long Term Stability (Ntte 3)	DV _{OUT} Dt	T _A = 25°C, t = 1000 hrs.		120	mV

Notes:

1. Load and Line Regulation are specified at a constant junction temperature. Pulse testing with low duty cycle is used. Changes in output voltage due to heating effects must be taken into account separately.
2. Short Circuit protection is only assured up to V_{IN} = -35V.
3. If not tested, shall be guaranteed to the specified limits.

The • denotes the specifications which apply over the full operating temperature range.

ELECTRICAL CHARACTERISTICS -15 Volt $V_{IN} = -23V, I_O = 500mA, -55^{\circ}C \leq T_A \leq 125^{\circ}C$ (unless otherwise specified)

Parameter	Symbol	Test Conditions	Min.	Max.	Unit
Output Voltage	V_{OUT}	$T_A = 25^{\circ}C$	-14.7	-15.3	V
		$V_{IN} = -17.5V$ to $-30V$	• -14.5	-15.5	V
Line Regulation (Note 1)	V_{RLINE}	$V_{IN} = -17.5V$ to $-30V$	•	25	mV
			•	50	mV
		$V_{IN} = -20V$ to $-26V$	•	15	mV
Load Regulation (Note 1)	V_{RLOAD}	$I_O = 5mA$ to $1.5A$ mp	•	35	mV
			•	75	mV
		$I_O = 250mA$ to $750mA$	•	21	mV
Standby Current Drain	I_{SCD}		•	6.0	mA
			•	6.5	mA
Standby Current Drain Change With Line	$D I_{SCD}$ (Line)	$V_{IN} = -17.5V$ to $-30V$	•	0.8	mA
Standby Current Drain Change With Load	$D I_{SCD}$ (Load)	$I_O = 5mA$ to $1000mA$	•	0.5	mA
Dropout Voltage	V_{DO}	$DV_{OUT} = 100mV, I_O = 1.0A$	•	2.5	V
Peak Output Current	I_{PK}	$T_A = 25^{\circ}C$	1.5	3.3	A
Short Circuit Current (Note 2)	I_{SC}	$V_{IN} = -35V$	•	1.2	A
Ripple Rejection	DV_{IN} DV_{OUT}	$f = 120Hz, DV_{IN} = -10V$	•	53	dB
		(Note 3)	•	50	dB
Output Noise Voltage (Note 3)	N_O	$T_A = 25^{\circ}C, f = 10Hz$ to $100kHz$		40	$\mu V/V$ RMS
Long Term Stability (Note 3)	$\frac{DV_{OUT}}{Dt}$	$T_A = 25^{\circ}C, t = 1000hrs.$		150	mV

Notes:

1. Load and Line Regulation are specified at a constant junction temperature. Pulse testing with low duty cycle is used. Changes in output voltage due to heating effects must be taken into account separately.
 2. Short Circuit protection is only assured up to $V_{IN} = -35V$.
 3. If not tested, shall be guaranteed to the specified limits.
- The • denotes the specifications which apply over the full operating temperature range.

TYPICAL PERFORMANCE CHARACTERISTICS

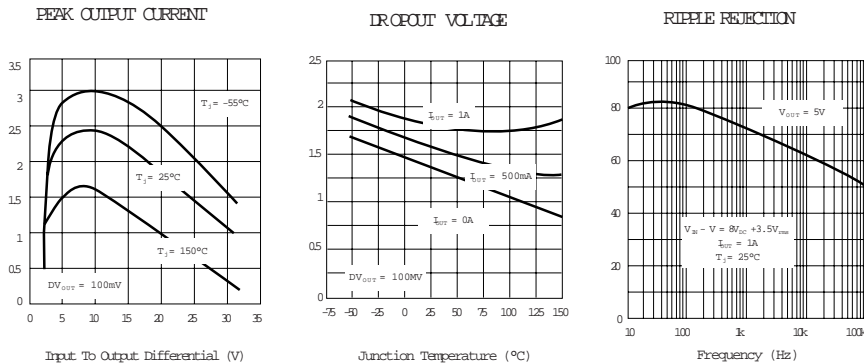

TYPICAL APPLICATIONS

Input bypass capacitors are recommended for stable operation of the OM7900 series of regulators over the input voltage and output current ranges. Output bypass capacitors will improve the transient response of the regulator.

The bypass capacitors, (2.2μF on the input, 1μF on the output) should be ceramic or solid tantalum which have good high frequency characteristics. If aluminum electrolytics are used, their values should be 10μF or larger. The bypass capacitors should be mounted with the shortest leads, and if possible, directly across the regulator terminals.

Fixed Output Regulator

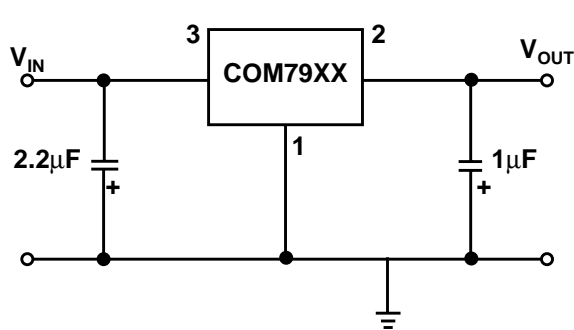

Basic Current Regulator

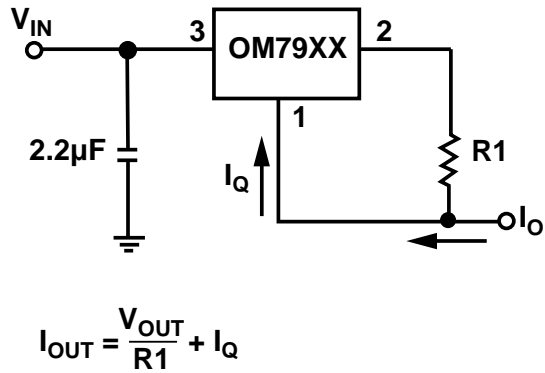

MECHANICAL OUTLINE
TO-257AA

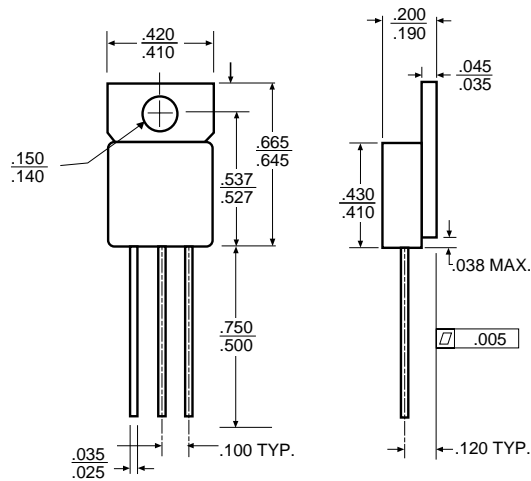

PIN CONNECTION

COM79XXT
Isolated
Front View
Pin 1: Ground
Pin 2: Input
Pin 3: Output
Tab: Isolated

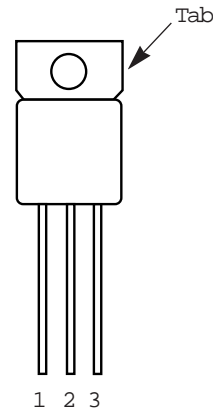

Note:

- Case is metal/hemetically sealed
- Isolated Tab/Glass Feedthroughs