

# 30 kRad - 100kRad RADIATION TOLERANT 7.5A, 5A, 3A, 1.5A LOW DROPOUT POSITIVE ADJUSTABLE REGULATORS



**30 kRad - 100kRad Rad Tolerant LDO  
 Positive Adjustable Voltage Regulators in  
 Hermetic Packages**

## FEATURES

- Operates Down to 1V Dropout, 1.5V @ Max. Current
- .015% Line Regulation
- .01% Load Regulation
- 1% Reference Voltage
- Hermetic Isolated and Non-Isolated Packages
- Radiation Tolerant up to 150 kRad (Si)
- Available Hi-Rel Screened, Class B and Class S, MIL-STD-883

## DESCRIPTION

These three terminal positive adjustable voltage regulators are designed to provide 7.5A, 5A, 3A, and 1.5A with higher efficiency than conventional voltage regulators. The devices are designed to operate to 1 Volt input to output differential and the dropout voltage is specified as a function of load current. All devices are pin compatible with older three terminal regulators. These devices are ideally suited for Space applications where small size, high reliability, and radiation tolerance is required. The high level of Radiation Tolerance of these devices makes them a desirable choice for LEO and many MEO and GEO communication satellites. Radiation testing is performed on a single wafer by wafer basis. Random die samples per wafer are selected, packaged and radiation tested to qualify each individual semiconductor wafer-by-wafer.

## ABSOLUTE MAXIMUM RATINGS @ 25°C

Input Voltage	.30 V
Operating Junction Temperature Range	- 55°C to + 150°C
Storage Temperature	- 65°C to + 150°C
Output Current - OMR183SC, NM	7.5 A
OMR184SC, NM	5 A
OMR185ST, SR, NM	3 A
OMR186ST, SR, NM	1.5 A
OMR186NH	0.5 A
Lead Temperature (Soldering 10 seconds)	300° C
Surface Mount Package Soldering Temperature	250° C
Radiation Tolerant - Total Dose, OMR183, OMR184	100k Rad (Si)
Total Dose, OMR185	50k Rad (Si)
Total Dose, OMR186	30k Rad (Si)

**Note:** OMR183 and OMR184 products are packaged in the TO-258 or SMD-1 Packages (7.5A & 5A).  
 OMR185 products are packaged in the TO-257, D<sup>2</sup> Pac or SMD-1 Packages (3A).  
 OMR186 products are packaged in the TO-257, D<sup>2</sup> Pac or SMD-1 or TO-205 Packages (1.5A & 0.5A).

## OMR183- OMR186 Series

### ELECTRICAL CHARACTERISTICS ( $T_C = 25^\circ\text{C}$ unless otherwise noted)

Parameter	Conditions	Min.	Typ.	Max.	Units
Reference Voltage	$I_{OUT} = 10\text{ mA}$ , $T_J = 25^\circ\text{C}$ $(V_{IN} - V_{OUT}) = 3\text{ V}$	1.238	1.250	1.262	V
	$10\text{ mA} \leq I_{OUT} \leq I_{FULL\text{ LOAD}}$ $1.5\text{ V} \leq (V_{IN} - V_{OUT}) \leq 25\text{ V}$ (Note 3)	1.220	1.250	1.270	V
Line Regulation	$I_{LOAD} = 10\text{ mA}$ , $1.5\text{ V} \leq (V_{IN} - V_{OUT}) \leq 15\text{ V}$ , $T_J = 25^\circ\text{C}$		0.015	0.2	%
			0.035	0.2	%
	$15\text{ V} \leq (V_{IN} - V_{OUT}) \leq 35\text{ V}$ (Notes 1 & 2)		0.05	0.5	%
Load Regulation	$(V_{IN} - V_{OUT}) = 3\text{ V}$ $10\text{ mA} \leq I_{OUT} \leq I_{FULL\text{ LOAD}}$ $T_J = 25^\circ\text{C}$		0.5	0.8	%
	(Notes 1, 2, 3)		.8	1.0	%
Dropout Voltage	$\Delta V_{REF} = 1\%$ , $I_{OUT} = I_{FULL\text{ LOAD}}$		1.3	1.5	V
Current Limit	OMR183 $(V_{IN} - V_{OUT}) = 5\text{ V}$ $(V_{IN} - V_{OUT}) = 25\text{ V}$		8.0		A
			0.4		A
	OMR184 $(V_{IN} - V_{OUT}) = 5\text{ V}$ $(V_{IN} - V_{OUT}) = 25\text{ V}$		5.5		A
			0.3		A
	OMR185 $(V_{IN} - V_{OUT}) = 5\text{ V}$ $(V_{IN} - V_{OUT}) = 25\text{ V}$		3.2		A
			0.2		A
OMR186 $(V_{IN} - V_{OUT}) = 5\text{ V}$ $(V_{IN} - V_{OUT}) = 25\text{ V}$		1.5		A	
		0.75		A	
Minimum Load Current	$(V_{IN} - V_{OUT}) = 25\text{ V}$		5	10	mA
Thermal Regulation	$T_A = 25^\circ\text{C}$ , 30 ms pulse Guaranteed by design		0.002	0.01	%/W
			0.003	0.15	%/W
			0.004	0.02	%/W
			0.010	0.05	%/W
Ripple Rejection	$f = 120\text{ Hz}$ $C_{ADJ} = 25\text{ }\mu\text{F Tantalum}$ $I_{OUT} = I_{FULL\text{ LOAD}}$ ( $V_{IN} - V_{OUT}) = 3\text{ V}$	60	75		dB
Adjust Pin Current	$T_J = 25^\circ\text{C}$		55		$\mu\text{A}$
Adjust Pin Current Change	$10\text{ mA} \leq I_{OUT} \leq I_{FULL\text{ LOAD}}$ $1.5\text{ V} \leq (V_{IN} - V_{OUT}) \leq 25\text{ V}$		0.2	5	$\mu\text{A}$
Temperature Stability	$-55^\circ\text{C} \leq T_J \leq +150^\circ\text{C}$		0.5		%
Long Term Stability	$T_A = 125^\circ\text{C}$ , 1000 Hrs.		0.3	1	%
Thermal Resistance	Junction-to-Case			4.2	$^\circ\text{C/W}$
		TO-257, D <sup>2</sup> Pac		2.75	$^\circ\text{C/W}$
		TO-258		3.5	$^\circ\text{C/W}$
		SMD-1		17	$^\circ\text{C/W}$
TO-205					$^\circ\text{C/W}$

**Note 1:** Load and line regulation are measured at a constant junction temperature by low duty cycle pulse testing.

**Note 2:** Line and load regulation are guaranteed up to the maximum power dissipation (OMR183/60W, OMR184/45W, OMR185/30W, OMR186/15W). Power dissipation is determined by the input/output differential and the output current. Guaranteed maximum power dissipation will not be available over the full input/output voltage range.

**Note 3:**  $I_{FULL\text{ LOAD}}$  curve is defined as the minimum value of current limit as a function of input to output voltage. Note that power dissipation is only achievable over a limited range of input to output voltage.

**Note 4:** Dropout voltage is specified over the full output current range of the device.

**Note 5:** Refer to curves for typical characteristics versus total dose radiation levels.

## OMNIREL'S RADIATION TEST PROCEDURE

- Radiation Testing is performed on a single wafer by wafer basis.
- Each wafer is identified and a random sample of 5 die per wafer is selected.
- The die are then individually assembled in a hermetic package, data logged, electrically tested, hi-rel screened and then submitted to radiation testing.
- The packaged die are submitted to Steady State Total Dose radiation per Method 1019, Condition A, at a dose rate of 50 RAD/sec biased at maximum supply voltage.
- Final electrical test is performed within two hours of both Total Dose Radiation level from a Cobalt 60 source and 168 hr, 100°C annealing process. Read and record data including two non-radiated control samples.
- The wafer is then qualified only if samples from wafers meet full electrical specifications after 150% of total dose rating as specified in each product data sheet.
- Omnirel's controlling specifications are as follows: For Voltage Regulators the controlling specification is MIL-PRF- 38534/MIL-STD-883. For Rectifiers/Schottky the controlling specification is MIL-PRF-19500/MIL-STD-750.

## AVAILABLE PRODUCT SCREENING

Standard Class Level Screening Per MIL-PRF-38535				
Screen	*Level B		*Level S	
	Test Method	Required	Test Method	Required
Wafer Lot Acceptance	----	----	5007	100%
Non-destructive Bond Pull	----	----	----	----
Pre-Cap Visual Inspection	2010	100%	2010	100%
Temperature Cycle	1010	100%	1010	100%
Constant Acceleration	2001	100%	2001	100%
Visual Inspection	----	100%	----	100%
PIND Test	----	----	2020	100%
Serialization	----	----	----	100%
Pre-Burn-In Electrical	Data Sheet	100%	Data Sheet	100%
Burn-In	1015/160 hrs.	100%	1015/240hrs.	100%
Interim Electrical	----	----	Data Sheet	100%
PDA Calculations	5% Functional	Lot	5% Functional	Lot
Final Electrical	Data Sheet	100%	Data Sheet	100%
Fine & Gross Seal	1014	100%	1014	100%
Radiographic	----	----	2012/Two Views	100%
Conformance Inspection**	GR A	100%	GR A	100%
Final Visual Inspection	2009	Sample	2009	Sample
<p>*Note: For "B" Level Screening add "M" to part number, for "S" Level Screening add "S" to part number. See Part Number Designator.</p> <p>**Note: Additional conformance inspection testing i.e. Group B, C, &amp; D optional.</p>				

## TYPICAL PERFORMANCE CHARACTERISTICS

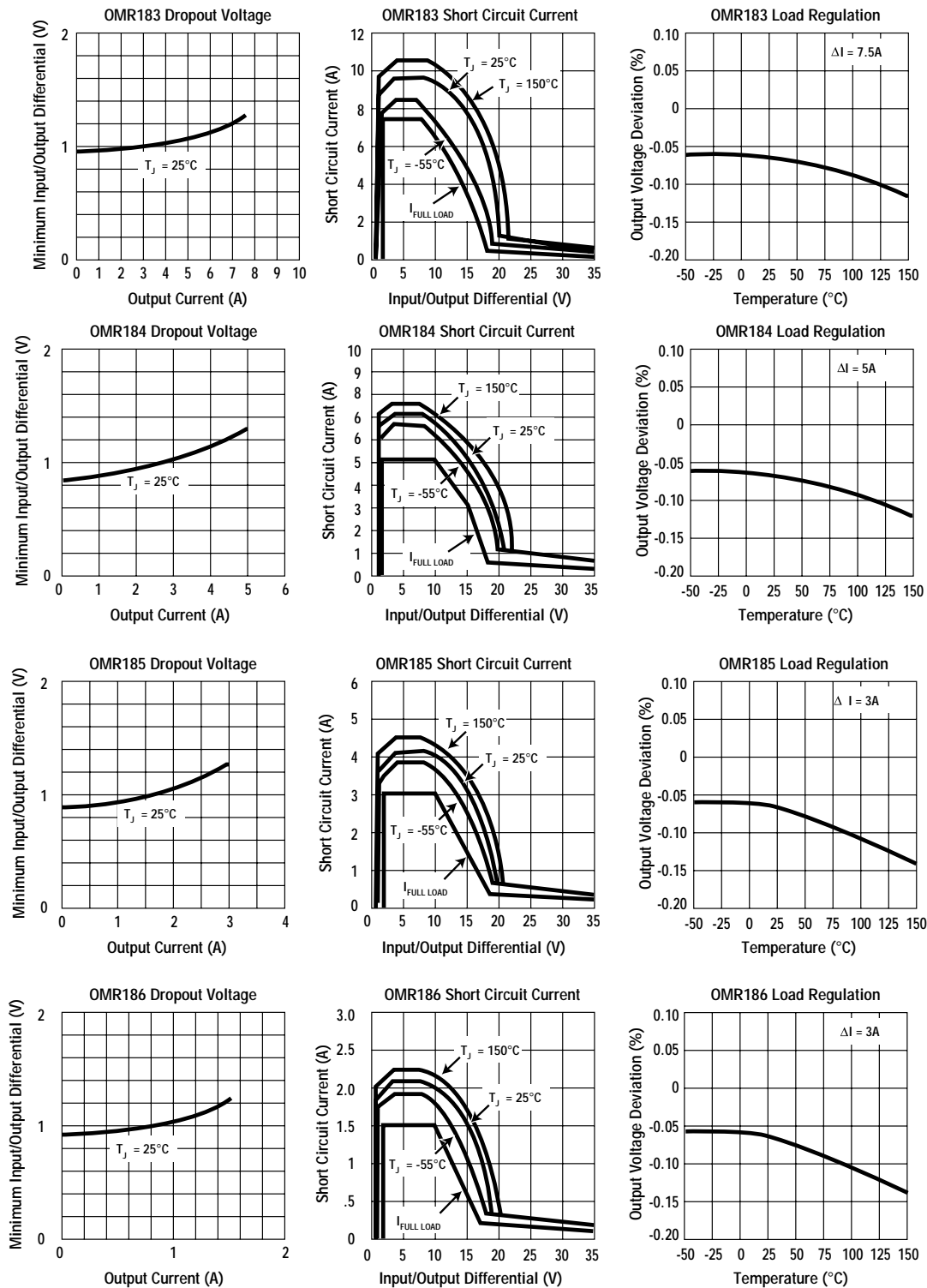

**APPLICATION NOTES**

**Stability**

The OMR183-186 Series requires the use of an output capacitor as part of the device frequency compensation. For all operating conditions, the addition of 150µF aluminum electrolytic or a 22µF solid tantalum on the output will ensure stability. Normally, capacitors much smaller than this can be used. Many different types of capacitors with widely varying characteristics are available. These capacitors differ in capacitor tolerance (sometimes ranging up to ±100%), equivalent series resistance, and capacitance temperature coefficient.

The 150µF or 22µF values given will ensure stability.

When the adjustment terminal is bypassed to improve the ripple rejection, the requirement for an output capacitor increases. The values of 22µF tantalum or 150µF aluminum cover all cases of bypassing the adjustment terminal. Without bypassing the adjustment terminal, smaller capacitors can be used with equally good results and the table below shows approximately what size capacitors are needed to ensure stability.

Normally, capacitor values on the order of 100µF are used in the output of many regulators to ensure good transient response with heavy load current changes. Output capacitance can be increased without limit and larger values of output capacitor further improve stability and transient response of the OM183SC regulators.

**Output Voltage — Adjustable Regulators**

The OMR183-OM186 devices develop a 1.25V reference voltage between the output and the adjust terminal (see below). By placing a resistor, R1, between these two terminals, a constant current is caused to flow through R1 and down through R2 to set the overall output voltage. Normally this current is the specified minimum load current of 10mA. Because I<sub>ADJ</sub> is very small and constant when compared with the current through R1, it represents a small error and can usually be ignored.

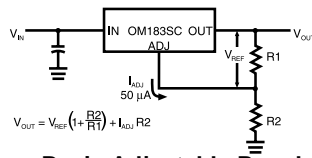

**Basic Adjustable Regulator**

**Recommended Capacitor Values**

Input	Output	Adjustment
10µF	10µF Tantalum, 50µF Aluminum	None
10µF	22µF Tantalum, 150µF Aluminum	20µF

**RADIATION TEST PROGRAM**

The following chart is a summary of the test data collected on Radiation Tolerant OMR183-186 series at various doses. The chart depicts the Total Radiation Dose that each device was exposed to on a step stress irradiation basis prior to failure. Failure is defined as any electrical test that does not meet the limits of the device per the published data sheet specifications after radiation testing.

Omnirel P/N	5K	10K	20K	30K	50K	60K	70K	80K	100K	150K	200K RAD
OMR183	[Redacted]										
Test Points						X			X	X	
OMR184	[Redacted]										
Test Points					X				X	X	
OMR185	[Redacted]										
Test Points	X	X	X	X	X			X	X		
OMR186	[Redacted]										
Test Points	X	X	X	X	X			X			

## TYPICAL RADIATION CURVES

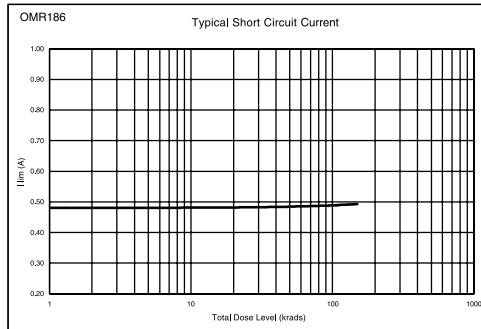
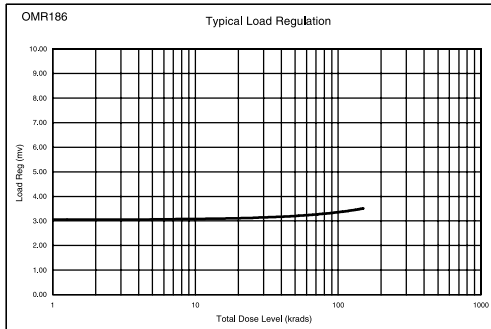
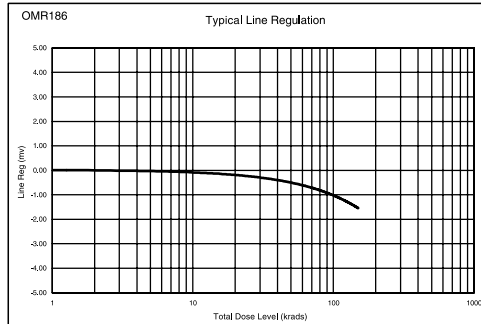
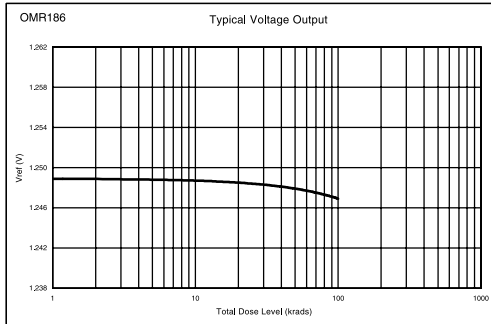
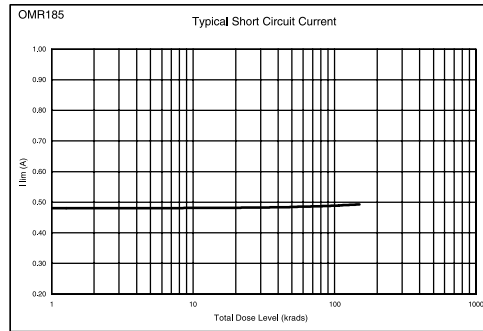
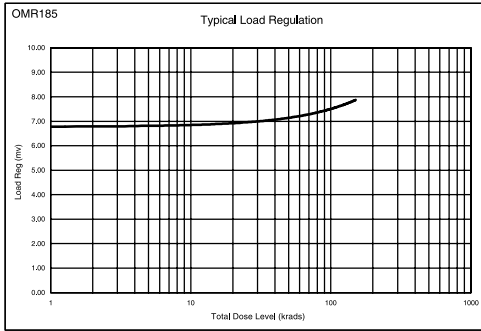
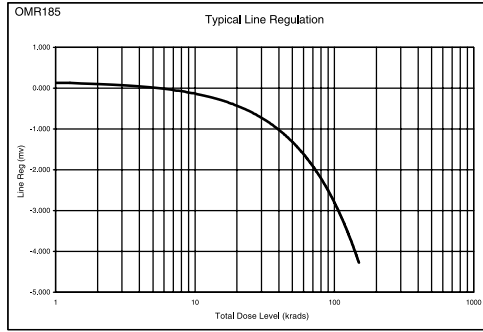
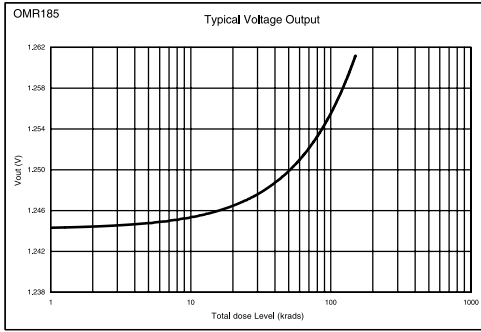

## TYPICAL RADIATION CURVES

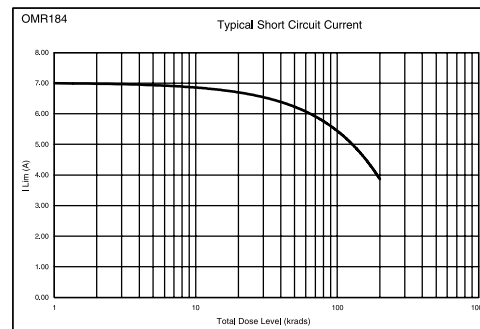
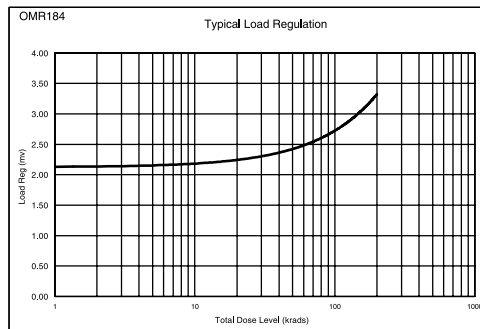
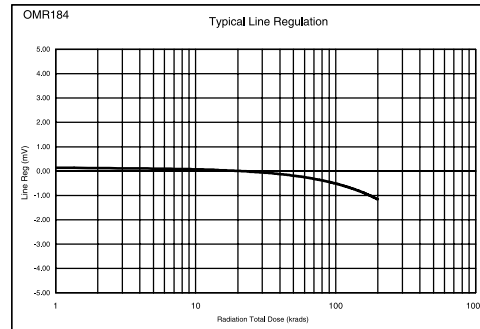
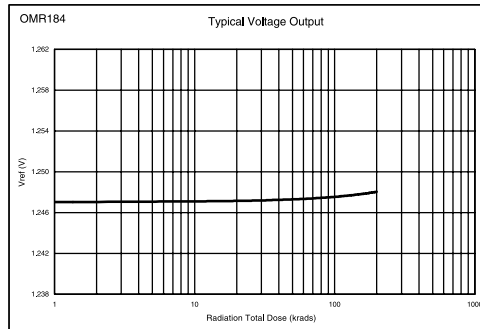
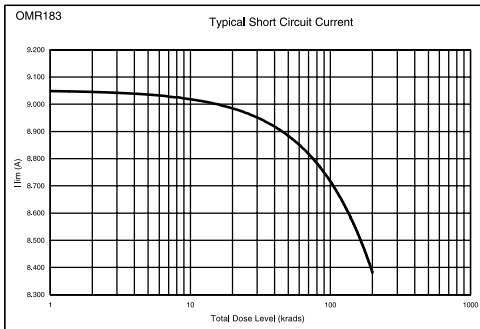
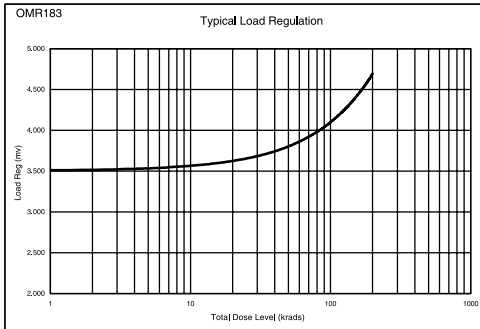
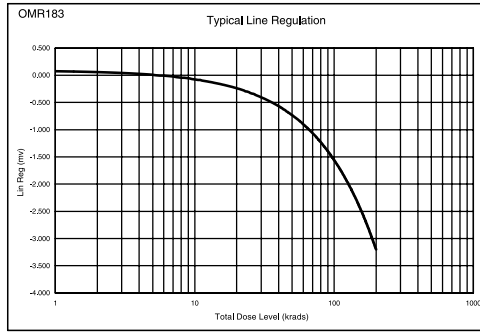
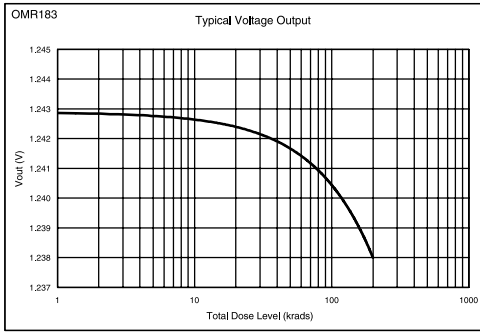

**MECHANICAL OUTLINES**

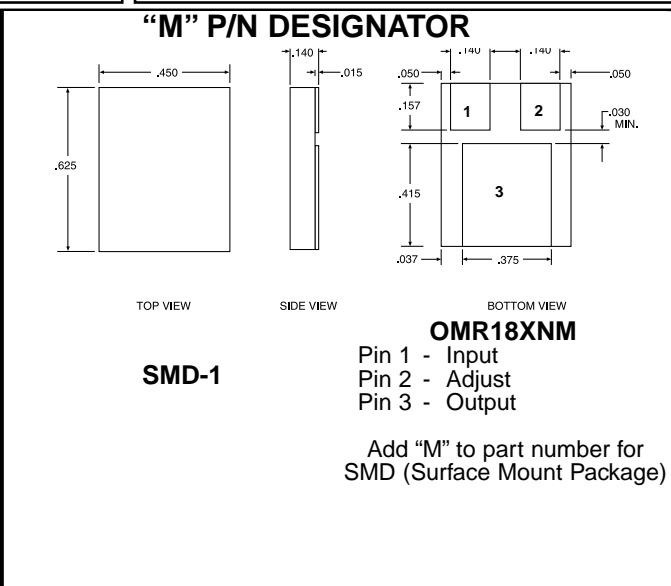
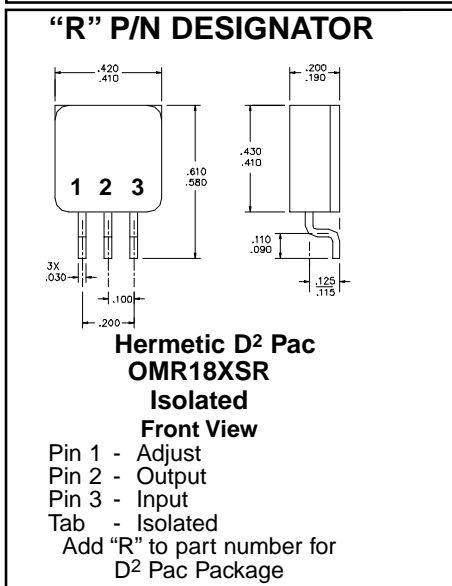
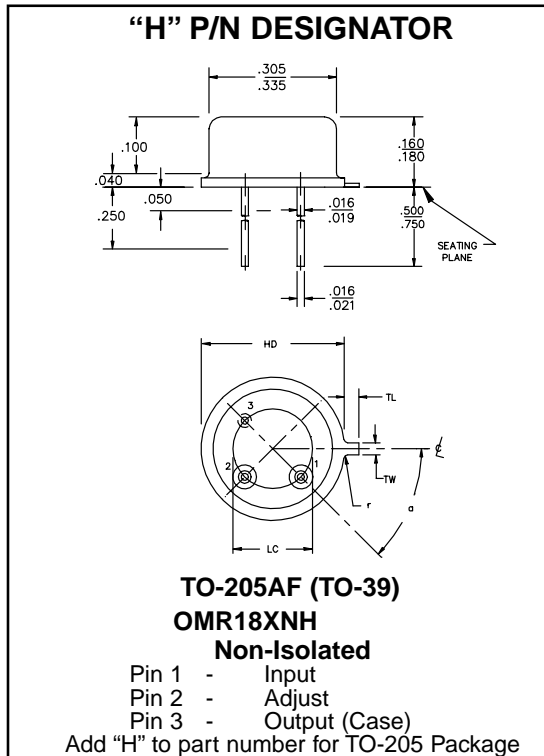
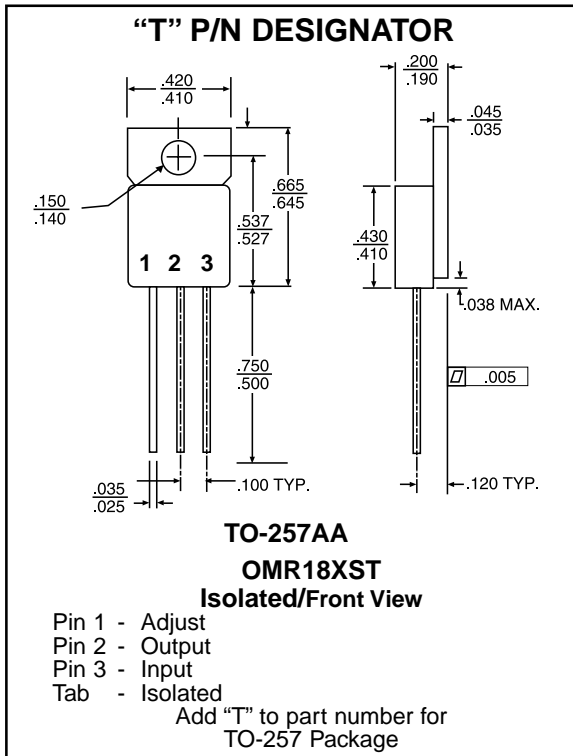

**PART NUMBER DESIGNATOR  
(Example OMR186STM)**

