



**MOTOROLA**

Order this document by MC1776C/D

# MC1776C

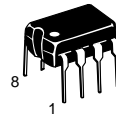
## Micropower Programmable Operational Amplifier

This extremely versatile operational amplifier features low power consumption and high input impedance. In addition, the quiescent currents within the device may be programmed by the choice of an external resistor value or current source applied to the  $I_{set}$  input. This allows the amplifier's characteristics to be optimized for input current and power consumption despite wide variations in operating power supply voltages.

- $\pm 1.2$  V to  $\pm 18$  V Operation
- Wide Programming Range
- Offset Null Capability
- No Frequency Compensation Required
- Low Input Bias Currents
- Short Circuit Protection

### PROGRAMMABLE OPERATIONAL AMPLIFIER

#### SEMICONDUCTOR TECHNICAL DATA



**P1 SUFFIX**  
PLASTIC PACKAGE  
CASE 626

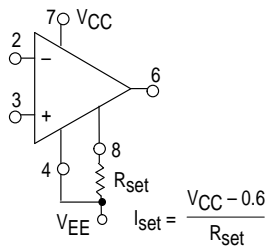


**D SUFFIX**  
PLASTIC PACKAGE  
CASE 751  
(SO-8)

#### Resistive Programming

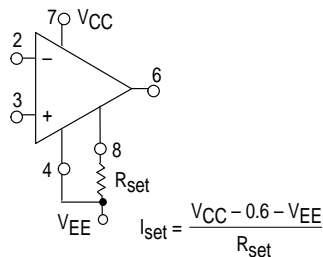
(See Figure 1)

##### $R_{set}$ to Ground



##### $R_{set}$ to Negative Supply

(Recommended for supply voltage less than  $\pm 6.0$  V)

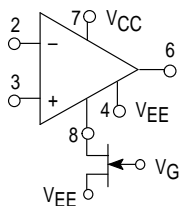


Typical $R_{set}$ Values		
$V_{CC}, V_{EE}$	$I_{set} = 1.5 \mu A$	$I_{set} = 15 \mu A$
$\pm 6.0$ V	3.6 M $\Omega$	360 k $\Omega$
$\pm 10$ V	6.2 M $\Omega$	620 k $\Omega$
$\pm 12$ V	7.5 M $\Omega$	750 k $\Omega$
$\pm 15$ V	10 M $\Omega$	1.0 M $\Omega$

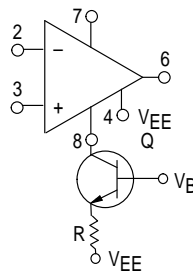
Typical $R_{set}$ Values		
$V_{CC}, V_{EE}$	$I_{set} = 1.5 \mu A$	$I_{set} = 15 \mu A$
$\pm 1.5$ V	1.6 M $\Omega$	160 k $\Omega$
$\pm 3.0$ V	3.6 M $\Omega$	360 k $\Omega$
$\pm 6.0$ V	7.5 M $\Omega$	750 k $\Omega$
$\pm 15$ V	20 M $\Omega$	2.0 M $\Omega$

#### Active Programming

##### FET Current Source

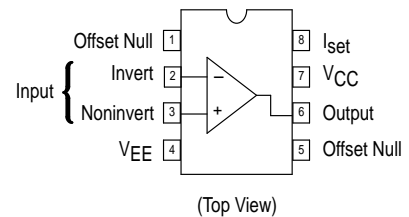


##### Bipolar Current Source



Pins not shown are not connected.

#### PIN CONNECTIONS



#### ORDERING INFORMATION

Device	Operating Temperature Range	Package
MC1776CD	$T_A = 0^\circ$ to $+70^\circ$ C	SO-8
MC1776CP1		Plastic DIP

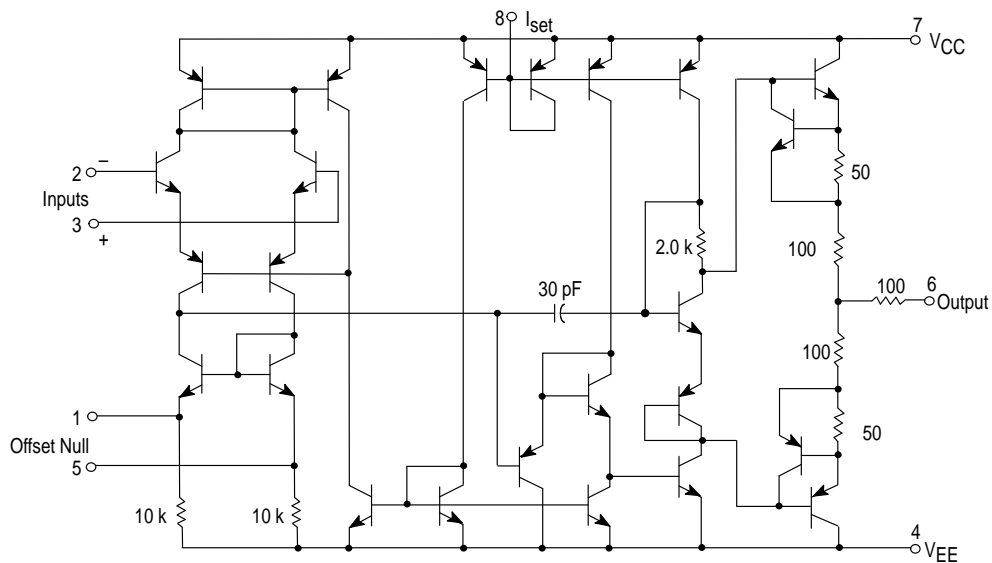
# MC1776C

**MAXIMUM RATINGS** ( $T_A = +25^\circ\text{C}$ , unless otherwise noted.)

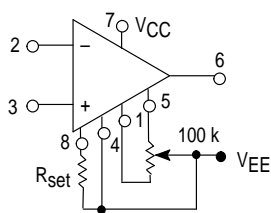
Rating	Symbol	Value	Unit
Power Supply Voltages	$V_{CC}, V_{EE}$	$\pm 18$	Vdc
Differential Input Voltage	$V_{ID}$	$\pm 30$	Vdc
Common Mode Input Voltage $V_{CC}$ and $ V_{EE}  < 15\text{ V}$ $V_{CC}$ and $ V_{EE}  \geq 15\text{ V}$	$V_{ICM}$	$V_{CC}, V_{EE}$ $\pm 15$	Vdc
Offset Null to $V_{EE}$ Voltage	$V_{off-V_{EE}}$	$\pm 0.5$	Vdc
Programming Current	$I_{set}$	500	$\mu\text{A}$
Programming Voltage (Voltage from $I_{set}$ Terminal to Ground)	$V_{set}$	$(V_{CC} - 2.0\text{ V})$ to $V_{CC}$	Vdc
Output Short Circuit Duration (Note 1)	$t_{SC}$	Indefinite	sec
Operating Temperature Range	$T_A$	0 to $+70$	$^\circ\text{C}$
Storage Temperature Range	$T_{stg}$	$-65$ to $+150$	$^\circ\text{C}$
Junction Temperature	$T_J$	150	$^\circ\text{C}$

NOTE 1. May be to ground or either supply voltage. Rating applies up to a case temperature of  $+125^\circ\text{C}$  or ambient temperature of  $+70^\circ\text{C}$  and  $I_{set} \leq 30\ \mu\text{A}$ .

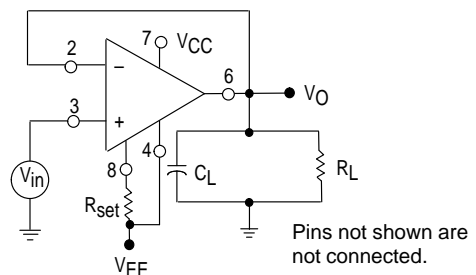
## Representative Schematic Diagram



## Voltage Offset Null Circuit



## Transient Response Test Circuit



## MC1776C

**ELECTRICAL CHARACTERISTICS** ( $V_{CC} = +3.0\text{ V}$ ,  $V_{EE} = -3.0\text{ V}$ ,  $I_{set} = 1.5\ \mu\text{A}$ ,  $T_A = +25^\circ\text{C}$ , unless otherwise noted.\*)

Characteristic	Symbol	Min	Typ	Max	Unit
Input Offset Voltage ( $R_S \leq 10\ \text{k}\Omega$ ) $T_A = +25^\circ\text{C}$ $T_{low}^* \leq T_A \leq T_{high}^*$	$V_{IO}$	– –	2.0 –	6.0 7.5	mV
Offset Voltage Adjustment Range	$V_{IOR}$	–	9.0	–	mV
Input Offset Current $T_A = +25^\circ\text{C}$ $T_A = T_{high}$ $T_A = T_{low}$	$I_{IO}$	– – –	0.7 – –	6.0 6.0 10	nA
Input Bias Current $T_A = +25^\circ\text{C}$ $T_A = T_{high}$ $T_A = T_{low}$	$I_{IB}$	– – –	2.0 – –	10 10 20	nA
Input Resistance	$r_i$	–	50	–	M $\Omega$
Input Capacitance	$c_i$	–	2.0	–	pF
Input Voltage Range $T_{low} \leq T_A \leq T_{high}$	$V_{ID}$	+1.0	–	–	V
Large Signal Voltage Gain $R_L \geq 75\ \text{k}\Omega$ , $V_O = \pm 1.0\ \text{V}$ , $T_A = +25^\circ\text{C}$ $R_L \geq 75\ \text{k}\Omega$ , $V_O = \pm 1.0\ \text{V}$ , $T_{low} \leq T_A \leq T_{high}$	$A_{VOL}$	25 k 25 k	200 k –	– –	V/V
Output Voltage Swing $R_L \geq 75\ \text{k}\Omega$ , $T_{low} \leq T_A \leq T_{high}$	$V_O$	$\pm 2.0$	$\pm 2.4$	–	V
Output Resistance	$r_o$	–	5.0	–	k $\Omega$
Output Short Circuit Current	$I_{SC}$	–	3.0	–	mA
Common Mode Rejection $R_S \leq 10\ \text{k}\Omega$ , $T_{low} \leq T_A \leq T_{high}$	CMR	70	86	–	dB
Supply Voltage Rejection Ratio $R_S \leq 10\ \text{k}\Omega$ , $T_{low} \leq T_A \leq T_{high}$	PSRR	–	25	200	$\mu\text{V/V}$
Supply Current $T_A = +25^\circ\text{C}$ $T_{low} \leq T_A \leq T_{high}$	$I_{CC}$ , $I_{EE}$	– –	13 –	20 25	$\mu\text{A}$
Power Dissipation $T_A = +25^\circ\text{C}$ $T_{low} \leq T_A \leq T_{high}$	$P_D$	– –	78 –	120 150	$\mu\text{W}$
Transient Response (Unity Gain) $V_{in} = 20\ \text{mV}$ , $R_L \geq 5.0\ \text{k}\Omega$ , $C_L = 100\ \text{pF}$ Rise Time Overshoot	$t_{TLH}$ $os$	– –	3.0 0	– –	$\mu\text{s}$ %
Slew Rate ( $R_L \geq 5.0\ \text{k}\Omega$ )	SR	–	0.03	–	V/ $\mu\text{s}$

\* $T_{low} = 0^\circ\text{C}$      $T_{high} = +70^\circ\text{C}$

## MC1776C

**ELECTRICAL CHARACTERISTICS** ( $V_{CC} = +3.0\text{ V}$ ,  $V_{EE} = -3.0\text{ V}$ ,  $I_{set} = 15\ \mu\text{A}$ ,  $T_A = +25^\circ\text{C}$ , unless otherwise noted.\*)

Characteristic	Symbol	Min	Typ	Max	Unit
Input Offset Voltage ( $R_S \leq 10\ \text{k}\Omega$ ) $T_A = +25^\circ\text{C}$ $T_{low}^* \leq T_A \leq T_{high}^*$	$V_{IO}$	–	2.0	6.0	mV
Offset Voltage Adjustment Range	$V_{IOR}$	–	18	–	mV
Input Offset Current $T_A = +25^\circ\text{C}$ $T_A = T_{high}$ $T_A = T_{low}$	$I_{IO}$	–	2.0	25	nA
Input Bias Current $T_A = +25^\circ\text{C}$ $T_A = T_{high}$ $T_A = T_{low}$	$I_{IB}$	–	15	50	nA
Input Resistance	$r_i$	–	5.0	–	M $\Omega$
Input Capacitance	$c_i$	–	2.0	–	pF
Input Voltage Range $T_{low} \leq T_A \leq T_{high}$	$V_{ID}$	$\pm 1.0$	–	–	V
Large Signal Voltage Gain $R_L \geq 5.0\ \text{k}\Omega$ , $V_O = \pm 1.0\ \text{V}$ , $T_A = +25^\circ\text{C}$ $R_L \geq 5.0\ \text{k}\Omega$ , $V_O = \pm 1.0\ \text{V}$ , $T_{low} \leq T_A \leq T_{high}$	$A_{VOL}$	25 k 25 k	200 k –	– –	V/V
Output Voltage Swing $R_L \geq 5.0\ \text{k}\Omega$ , $T_{low} \leq T_A \leq T_{high}$	$V_O$	$\pm 2.0$	$\pm 2.1$	–	V
Output Resistance	$r_o$	–	1.0	–	k $\Omega$
Output Short Circuit Current	$I_{SC}$	–	5.0	–	mA
Common Mode Rejection $R_S \leq 10\ \text{k}\Omega$ , $T_{low} \leq T_A \leq T_{high}$	CMR	70	86	–	dB
Supply Voltage Rejection Ratio $R_S \leq 10\ \text{k}\Omega$ , $T_{low} \leq T_A \leq T_{high}$	PSRR	–	25	200	$\mu\text{V/V}$
Supply Current $T_A = +25^\circ\text{C}$ $T_{low} \leq T_A \leq T_{high}$	$I_{CC}$ , $I_{EE}$	–	130	170	$\mu\text{A}$
Power Dissipation $T_A = +25^\circ\text{C}$ $T_{low} \leq T_A \leq T_{high}$	$P_D$	–	780	1020	$\mu\text{W}$
Transient Response (Unity Gain) $V_{in} = 20\ \text{mV}$ , $R_L \geq 5.0\ \text{k}\Omega$ , $C_L = 100\ \text{pF}$ Rise Time Overshoot	$t_{TLH}$ $os$	–	0.6 5.0	–	$\mu\text{s}$ %
Slew Rate ( $R_L \geq 5.0\ \text{k}\Omega$ )	$S_R$	–	0.35	–	V/ $\mu\text{s}$

\* $T_{low} = 0^\circ\text{C}$      $T_{high} = +70^\circ\text{C}$

## MC1776C

**ELECTRICAL CHARACTERISTICS** ( $V_{CC} = +15\text{ V}$ ,  $V_{EE} = -15\text{ V}$ ,  $I_{set} = 1.5\ \mu\text{A}$ ,  $T_A = +25^\circ\text{C}$ , unless otherwise noted.\*)

Characteristic	Symbol	Min	Typ	Max	Unit
Input Offset Voltage ( $R_S \leq 10\ \text{k}\Omega$ ) $T_A = +25^\circ\text{C}$ $T_{low}^* \leq T_A \leq T_{high}^*$	$V_{IO}$	–	2.0	6.0	mV
		–	–	7.5	
Offset Voltage Adjustment Range	$V_{IOR}$	–	9.0	–	mV
Input Offset Current $T_A = +25^\circ\text{C}$ $T_A = T_{high}$ $T_A = T_{low}$	$I_{IO}$	–	0.7	6.0	nA
		–	–	6.0	
		–	–	10	
Input Bias Current $T_A = +25^\circ\text{C}$ $T_A = T_{high}$ $T_A = T_{low}$	$I_{IB}$	–	2.0	10	nA
		–	–	10	
		–	–	20	
Input Resistance	$r_i$	–	50	–	$\text{M}\Omega$
Input Capacitance	$c_i$	–	2.0	–	pF
Input Voltage Range $T_{low} \leq T_A \leq T_{high}$	$V_{ID}$	$\pm 10$	–	–	V
Large Signal Voltage Gain $R_L \geq 75\ \text{k}\Omega$ , $V_O = \pm 10\ \text{V}$ , $T_A = +25^\circ\text{C}$ $R_L \geq 75\ \text{k}\Omega$ , $V_O = \pm 10\ \text{V}$ , $T_{low} \leq T_A \leq T_{high}$	$A_{VOL}$	50 k 50 k	400 k –	– –	V/V
Output Voltage Swing $R_L \geq 75\ \text{k}\Omega$ , $T_A = +25^\circ\text{C}$ $R_L \geq 75\ \text{k}\Omega$ , $T_{low} \leq T_A \leq T_{high}$	$V_O$	$\pm 12$ $\pm 10$	$\pm 14$ –	– –	V
Output Resistance	$r_o$	–	5.0	–	$\text{k}\Omega$
Output Short Circuit Current	$I_{SC}$	–	3.0	–	mA
Common Mode Rejection $R_S \leq 10\ \text{k}\Omega$ , $T_{low} \leq T_A \leq T_{high}$	CMR	70	90	–	dB
Supply Voltage Rejection Ratio $R_S \leq 10\ \text{k}\Omega$ , $T_{low} \leq T_A \leq T_{high}$	PSRR	–	25	200	$\mu\text{V}/\text{V}$
Supply Current $T_A = +25^\circ\text{C}$ $T_{low} \leq T_A \leq T_{high}$	$I_{CC}$ , $I_{EE}$	– –	20 –	30 35	$\mu\text{A}$
Power Dissipation $T_A = +25^\circ\text{C}$ $T_{low} \leq T_A \leq T_{high}$	$P_D$	– –	780 –	0.9 1.05	mW
Transient Response (Unity Gain) $V_{in} = 20\ \text{mV}$ , $R_L \geq 5.0\ \text{k}\Omega$ , $C_L = 100\ \text{pF}$ Rise Time Overshoot	$t_{TLH}$ $t_{os}$	– –	1.6 0	– –	$\mu\text{s}$ %
Slew Rate ( $R_L \geq 5.0\ \text{k}\Omega$ )	$S_R$	–	0.1	–	$\text{V}/\mu\text{s}$

\* $T_{low} = 0^\circ\text{C}$      $T_{high} = +70^\circ\text{C}$

## MC1776C

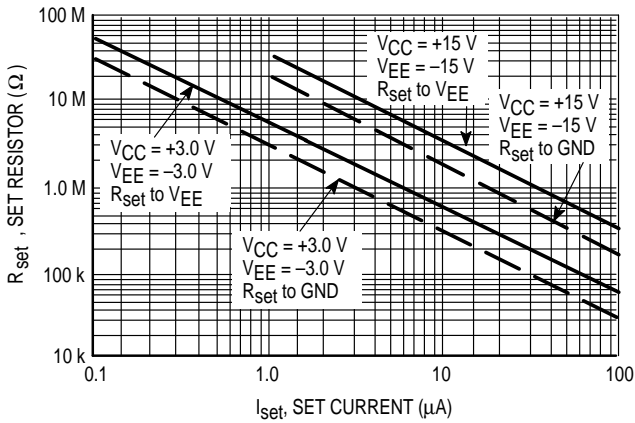
### ELECTRICAL CHARACTERISTICS ( $V_{CC} = +15\text{ V}$ , $V_{EE} = -15\text{ V}$ , $I_{set} = 15\text{ }\mu\text{A}$ , $T_A = +25^\circ\text{C}$ , unless otherwise noted.\*)

Characteristic	Symbol	Min	Typ	Max	Unit
Input Offset Voltage ( $R_S \leq 10\text{ k}\Omega$ ) $T_A = +25^\circ\text{C}$ $T_{low}^* \leq T_A \leq T_{high}^*$	$V_{IO}$	–	2.0	6.0	mV
Offset Voltage Adjustment Range	$V_{IOR}$	–	18	–	mV
Input Offset Current $T_A = +25^\circ\text{C}$ $T_A = T_{high}$ $T_A = T_{low}$	$I_{IO}$	–	2.0	25	nA
Input Bias Current $T_A = +25^\circ\text{C}$ $T_A = T_{high}$ $T_A = T_{low}$	$I_{IB}$	–	15	50	nA
Input Resistance	$r_i$	–	5.0	–	$M\Omega$
Input Capacitance	$c_i$	–	2.0	–	pF
Input Voltage Range $T_{low} \leq T_A \leq T_{high}$	$V_{ID}$	$\pm 10$	–	–	V
Large Signal Voltage Gain $R_L \geq 5.0\text{ k}\Omega$ , $V_O = \pm 10\text{ V}$ , $T_A = +25^\circ\text{C}$ $R_L \geq 75\text{ k}\Omega$ , $V_O = \pm 10\text{ V}$ , $T_{low} \leq T_A \leq T_{high}$	$A_{VOL}$	50 k 50 k	400 k –	– –	V/V
Output Voltage Swing $R_L \geq 5.0\text{ k}\Omega$ , $T_A = +25^\circ\text{C}$ $R_L \geq 75\text{ k}\Omega$ , $T_{low} \leq T_A \leq T_{high}$	$V_O$	$\pm 10$ $\pm 10$	$\pm 13$ –	– –	V
Output Resistance	$r_o$	–	1.0	–	$k\Omega$
Output Short Circuit Current	$I_{SC}$	–	12	–	mA
Common Mode Rejection $R_S \leq 10\text{ k}\Omega$ , $T_{low} \leq T_A \leq T_{high}$	CMR	70	90	–	dB
Supply Voltage Rejection Ratio $R_S \leq 10\text{ k}\Omega$ , $T_{low} \leq T_A \leq T_{high}$	PSRR	–	25	200	$\mu\text{V/V}$
Supply Current $T_A = +25^\circ\text{C}$ $T_{low} \leq T_A \leq T_{high}$	$I_{CC}$ , $I_{EE}$	– –	160 –	190 200	$\mu\text{A}$
Power Dissipation $T_A = +25^\circ\text{C}$ $T_{low} \leq T_A \leq T_{high}$	$P_D$	– –	– –	5.7 6.0	$\mu\text{W}$
Transient Response (Unity Gain) $V_{in} = 20\text{ mV}$ , $R_L \geq 5.0\text{ k}\Omega$ , $C_L = 100\text{ pF}$ Rise Time Overshoot	$t_{TLH}$ $t_{os}$	– –	0.35 10	– –	$\mu\text{s}$ %
Slew Rate ( $R_L \geq 5.0\text{ k}\Omega$ )	$S_R$	–	0.8	–	$\text{V}/\mu\text{s}$

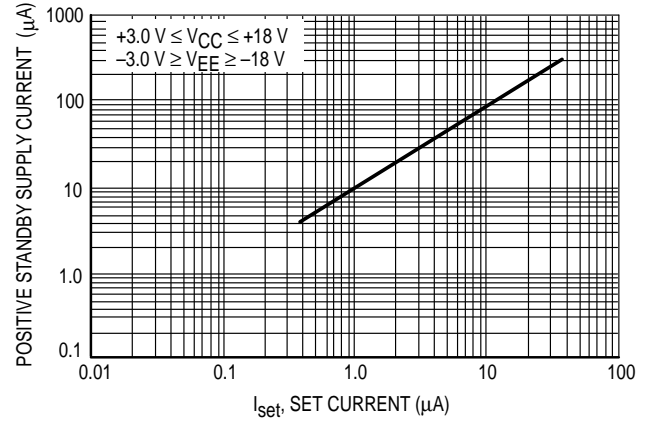
\* $T_{low} = 0^\circ\text{C}$      $T_{high} = +70^\circ\text{C}$

# MC1776C

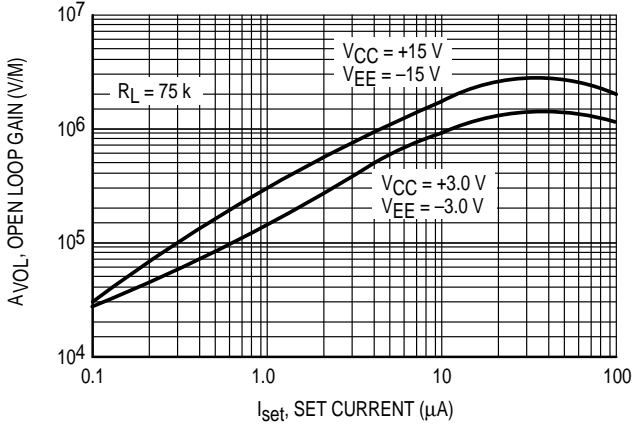
**Figure 1. Set Current versus Set Resistor**



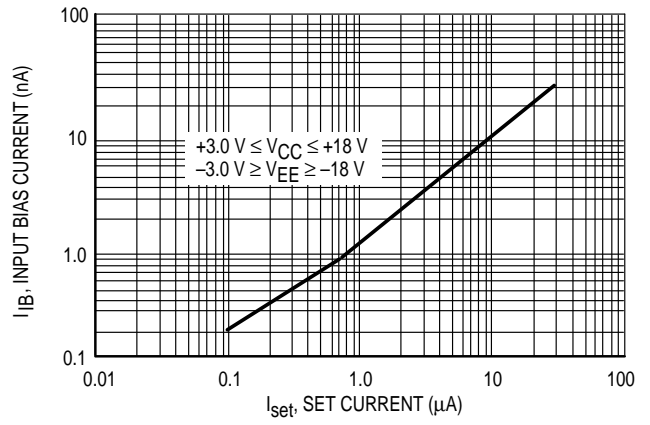
**Figure 2. Positive Standby Supply Current versus Set Current**



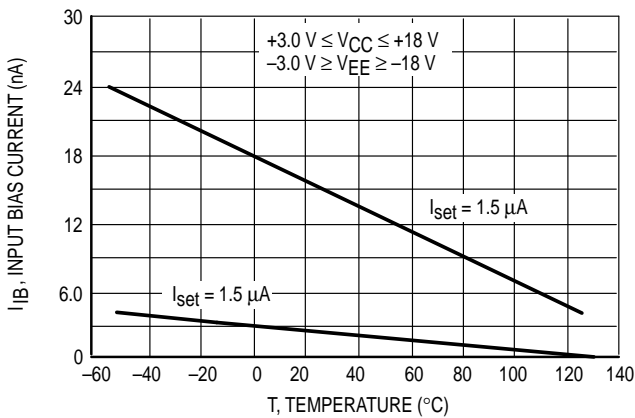
**Figure 3. Open Loop Gain versus Set Current**



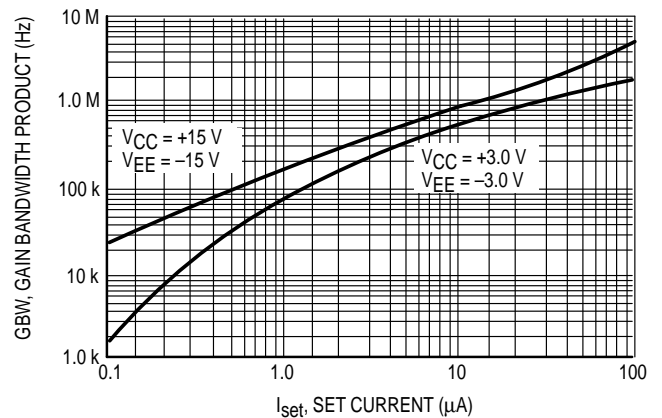
**Figure 4. Input Bias Current versus Set Current**



**Figure 5. Input Bias Current versus Ambient Temperature**

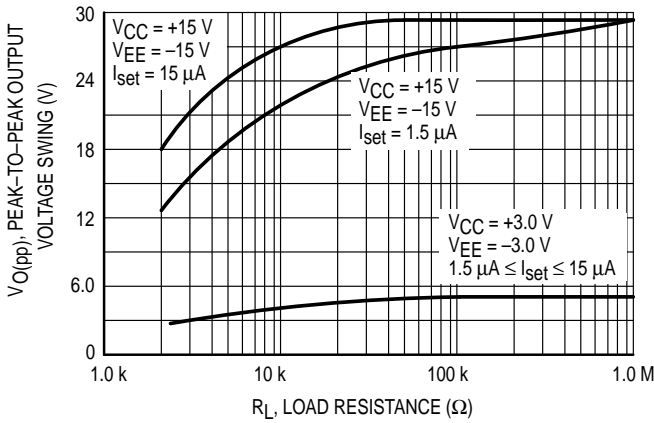


**Figure 6. Gain Bandwidth Product versus Set Current**

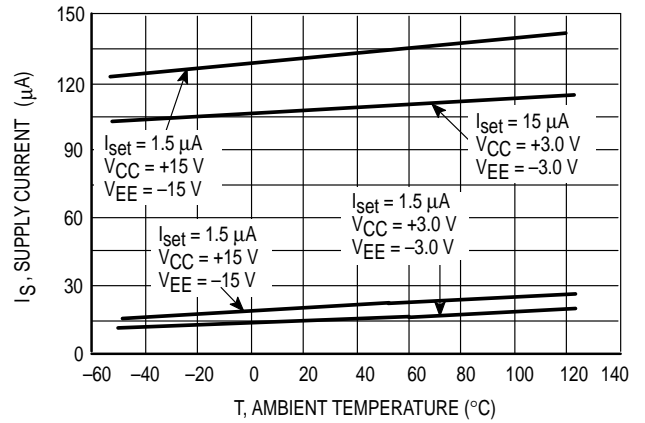


# MC1776C

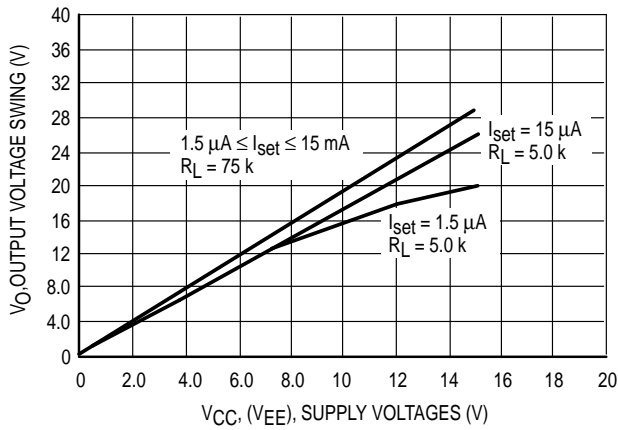
**Figure 7. Output Voltage Swing versus Load Resistance**



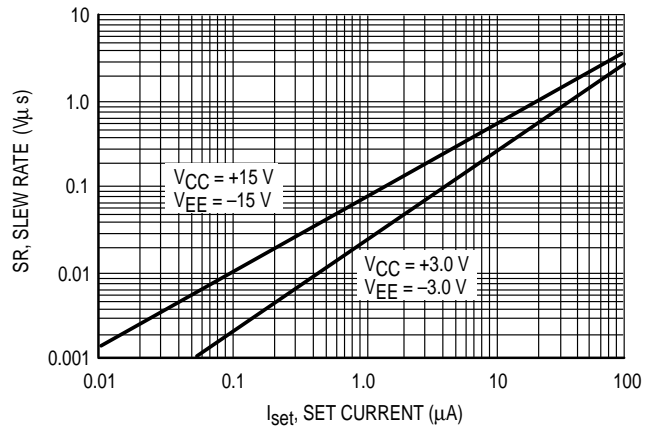
**Figure 8. Supply Current versus Ambient Temperature**



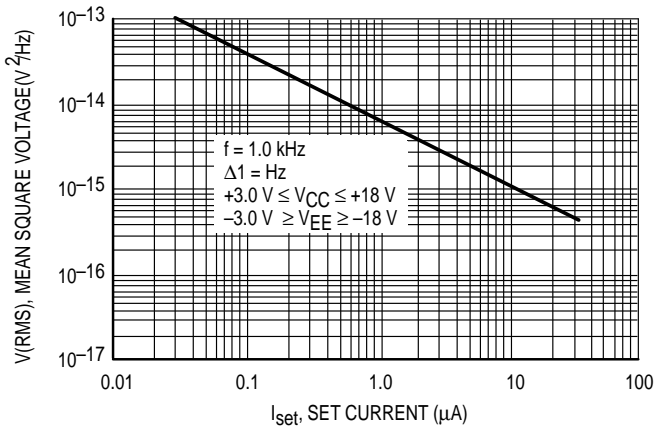
**Figure 9. Output Voltage Swing versus Supply Voltage**



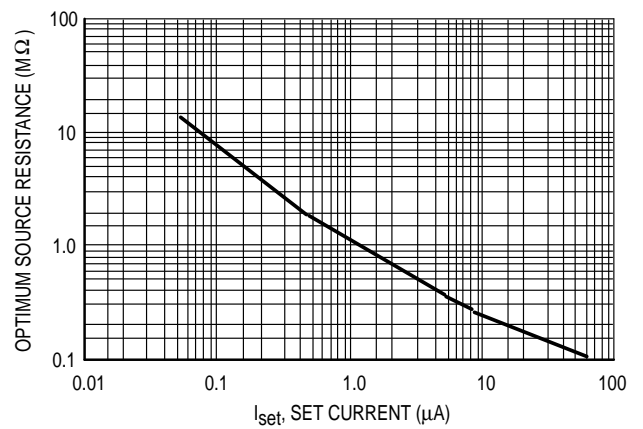
**Figure 10. Slew Rate versus Set Current**



**Figure 11. Input Noise Voltage versus Set Current**



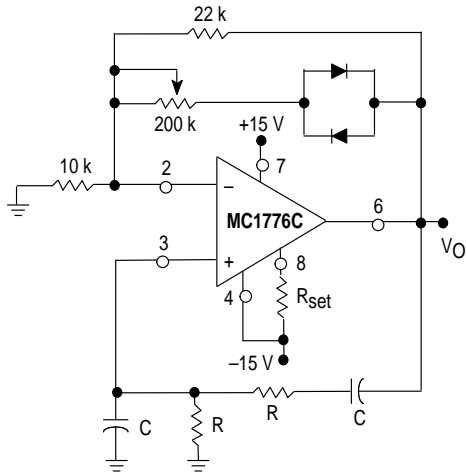
**Figure 12. Optimum Source Resistance for Minimum Noise versus Set Current**





# MC1776C

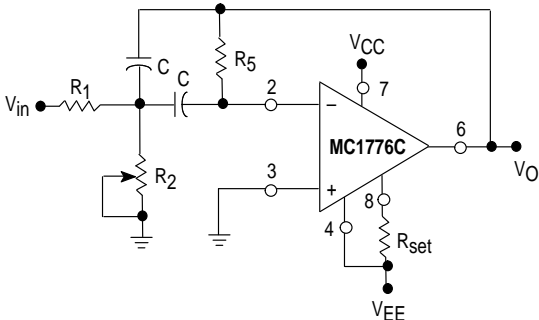
**Figure 13. Wien Bridge Oscillator**



$$f_0 = \frac{1}{2\pi RC} \quad (\text{for } f_0 = 1.0 \text{ kHz})$$

$R = 16 \text{ k}\Omega$   
 $C = 0.01 \mu\text{F}$

**Figure 14. Multiple Feedback Bandpass Filter**



For a given:  
 $f_0$  = center frequency  
 $A(f_0)$  = Gain at center frequency  
 $Q$  = quality factor

Choose a value for C, then

$$R_5 = \frac{Q}{\pi f_0 C}$$

$$R_1 = \frac{R_5}{2A(f_0)}$$

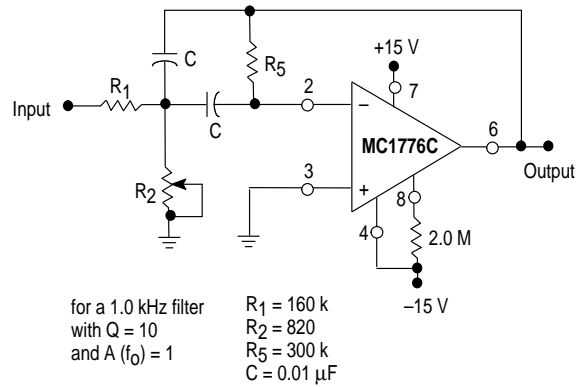
$$R_2 = \frac{R_1 R_5}{4Q^2 R_1 - R_5}$$

To obtain less than 10% error from the operational amplifier:

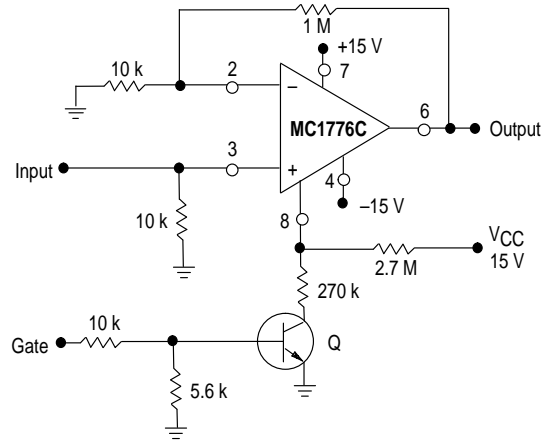
$$\frac{Q_0 f_0}{\text{GBW}} \leq 0.1$$

where  $f_0$  and GBW are expressed in Hz. GBW is available from Figure 6 as a function of Set Current,  $I_{\text{set}}$ .

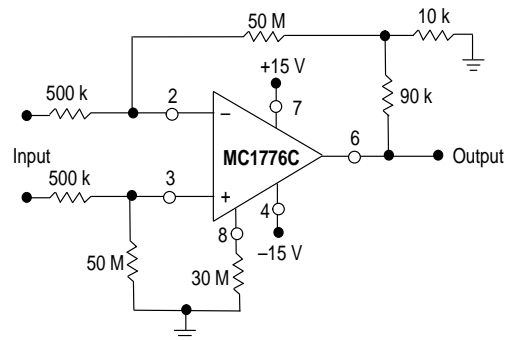
**Figure 15. Multiple Feedback Bandpass Filter (1.0 kHz)**



**Figure 16. Gated Amplifier**



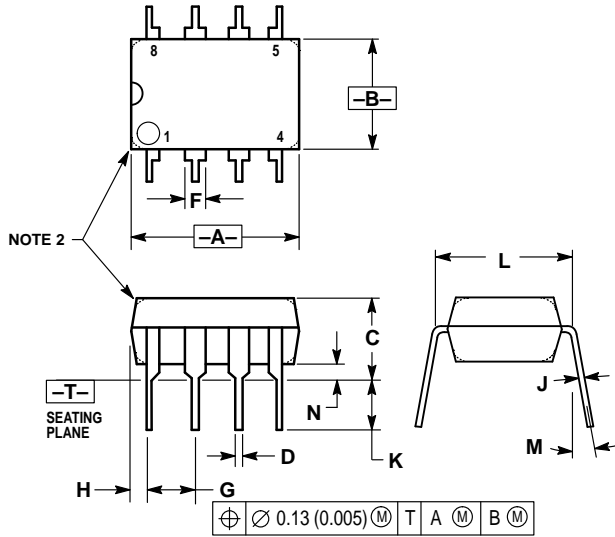
**Figure 17. High Input Impedance Amplifier**



# MC1776C

## OUTLINE DIMENSIONS

**P1 SUFFIX**  
**PLASTIC PACKAGE**  
**CASE 626-05**  
**ISSUE K**

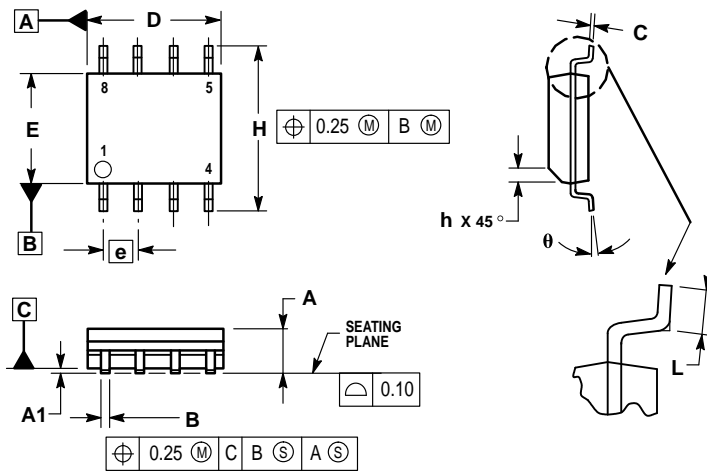


**NOTES:**

1. DIMENSION L TO CENTER OF LEAD WHEN FORMED PARALLEL.
2. PACKAGE CONTOUR OPTIONAL (ROUND OR SQUARE CORNERS).
3. DIMENSIONING AND TOLERANCING PER ANSI Y14.5M, 1982.

DIM	MILLIMETERS		INCHES	
	MIN	MAX	MIN	MAX
A	9.40	10.16	0.370	0.400
B	6.10	6.60	0.240	0.260
C	3.94	4.45	0.155	0.175
D	0.38	0.51	0.015	0.020
F	1.02	1.78	0.040	0.070
G	2.54 BSC		0.100 BSC	
H	0.76	1.27	0.030	0.050
J	0.20	0.30	0.008	0.012
K	2.92	3.43	0.115	0.135
L	7.62 BSC		0.300 BSC	
M	—		10°	
N	0.76	1.01	0.030	0.040

**D SUFFIX**  
**PLASTIC PACKAGE**  
**CASE 751-05**  
**(SO-8)**  
**ISSUE R**




**NOTES:**

1. DIMENSIONING AND TOLERANCING PER ASME Y14.5M, 1994.
2. DIMENSIONS ARE IN MILLIMETERS.
3. DIMENSION D AND E DO NOT INCLUDE MOLD PROTRUSION.
4. MAXIMUM MOLD PROTRUSION 0.15 PER SIDE.
5. DIMENSION B DOES NOT INCLUDE MOLD PROTRUSION. ALLOWABLE DAMBAR PROTRUSION SHALL BE 0.127 TOTAL IN EXCESS OF THE B DIMENSION AT MAXIMUM MATERIAL CONDITION.

DIM	MILLIMETERS	
	MIN	MAX
A	1.35	1.75
A1	0.10	0.25
B	0.35	0.49
C	0.18	0.25
D	4.80	5.00
E	3.80	4.00
e	1.27 BSC	
H	5.80	6.20
h	0.25	0.50
L	0.40	1.25
θ	0° - 7°	

## MC1776C

Motorola reserves the right to make changes without further notice to any products herein. Motorola makes no warranty, representation or guarantee regarding the suitability of its products for any particular purpose, nor does Motorola assume any liability arising out of the application or use of any product or circuit, and specifically disclaims any and all liability, including without limitation consequential or incidental damages. "Typical" parameters which may be provided in Motorola data sheets and/or specifications can and do vary in different applications and actual performance may vary over time. All operating parameters, including "Typicals" must be validated for each customer application by customer's technical experts. Motorola does not convey any license under its patent rights nor the rights of others. Motorola products are not designed, intended, or authorized for use as components in systems intended for surgical implant into the body, or other applications intended to support or sustain life, or for any other application in which the failure of the Motorola product could create a situation where personal injury or death may occur. Should Buyer purchase or use Motorola products for any such unintended or unauthorized application, Buyer shall indemnify and hold Motorola and its officers, employees, subsidiaries, affiliates, and distributors harmless against all claims, costs, damages, and expenses, and reasonable attorney fees arising out of, directly or indirectly, any claim of personal injury or death associated with such unintended or unauthorized use, even if such claim alleges that Motorola was negligent regarding the design or manufacture of the part. Motorola and  are registered trademarks of Motorola, Inc. Motorola, Inc. is an Equal Opportunity/Affirmative Action Employer.

# MC1776C

**How to reach us:**

**USA/EUROPE/Locations Not Listed:** Motorola Literature Distribution;  
P.O. Box 20912; Phoenix, Arizona 85036. 1-800-441-2447 or 602-303-5454

**MFAX:** RMFAX0@email.sps.mot.com – TOUCHTONE 602-244-6609  
**INTERNET:** <http://Design-NET.com>

**JAPAN:** Nippon Motorola Ltd.; Tatsumi-SPD-JLDC, 6F Seibu-Butsuryu-Center,  
3-14-2 Tatsumi Koto-Ku, Tokyo 135, Japan. 03-81-3521-8315

**ASIA/PACIFIC:** Motorola Semiconductors H.K. Ltd.; 8B Tai Ping Industrial Park,  
51 Ting Kok Road, Tai Po, N.T., Hong Kong. 852-26629298



**MOTOROLA**



MC1776C/D

