



MOTOROLA

Order this document by LM2935/D

LM2935

Low Dropout Dual Voltage Regulator

The LM2935 is a dual positive 5.0 V low dropout voltage regulator, designed for standby power systems. The main output is capable of supplying 750 mA for microprocessor power, and can be turned "on" and "off" by the switch/reset input. The other output is dedicated for standby operation of volatile memory, and is capable of supplying up to 10 mA loads. The total device features a low quiescent current of 3.0 mA or less when supplying 10 mA from the standby output.

This part was designed for harsh automotive environments and is therefore immune to many input supply voltage problems such as reverse battery (-12 V), double battery (+24 V), and load dump transients (+60 V).

- Two Regulated 5.0 V Outputs
- Main Output Current in Excess of 750 mA
- On/Off Control of Main Output
- Standby Output Current in Excess of 10 mA
- Low Input/Output Differential of Less than 0.6 V at 500 mA
- Short Circuit Current Limiting
- Internal Thermal Shutdown
- Low Voltage Indicator Output
- Designed for Automotive Environment Including
 - Reverse Battery Protection
 - Double Battery Protection
 - Load Dump Protection
 - Reverse Transient Protection
- Economical 5-Lead TO-220 Package with Two Optional Leadforms
- Also Available in Surface Mount D²PAK Package

LOW DROPOUT DUAL VOLTAGE REGULATOR

SEMICONDUCTOR TECHNICAL DATA

TH SUFFIX
PLASTIC PACKAGE
CASE 314A

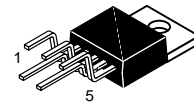
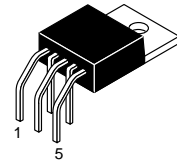

TV SUFFIX
PLASTIC PACKAGE
CASE 314B

Heatsink surface connected to Pin 3.

T SUFFIX
PLASTIC PACKAGE
CASE 314D

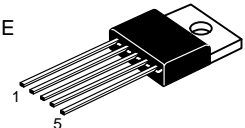

- Pin
1. Input Voltage/V_{CC}
 2. Main Output
 3. Ground
 4. Switch/Reset
 5. Standby/Output

ORDERING INFORMATION

Device	Operating Temperature Range	Package
LM2935D2T	T _J = -40° to +125°C	Surface Mount
LM2935T		Plastic Power
LM2935TH		Horizontal Mount
LM2935TV		Vertical Mount

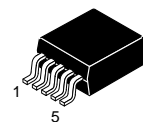

D2T SUFFIX
PLASTIC PACKAGE
CASE 936A
(D²PAK)

Heatsink surface (shown as terminal 6 in case outline drawing) is connected to Pin 3.

LM2935

Typical Application Circuit

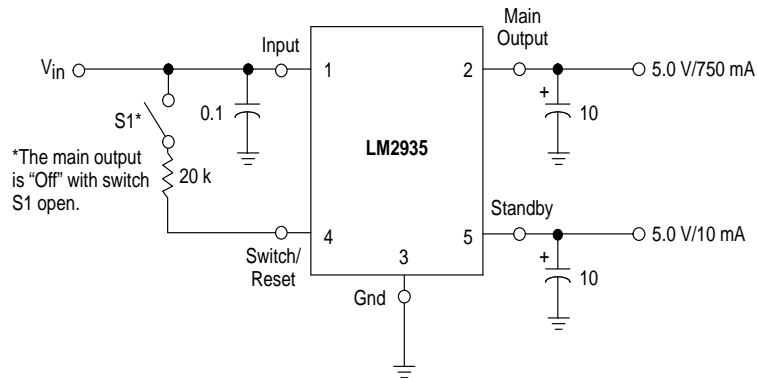

An input bypass capacitor is recommended if the regulator is located more than 4" from the supply input filter. The LM2935 is not internally compensated and thus requires an external output capacitor for stability. A minimum capacitance of 10 μF is recommended. The actual capacitance value is dependent upon load current, temperature, and the capacitor's equivalent series resistance (ESR). The least stable condition is encountered at maximum load current and minimum ambient temperature.

This device contains 29 active transistors.

MAXIMUM RATINGS

Rating	Symbol	Value	Unit
Input Voltage Continuous	V_I	60	Vdc
Transient Reverse Polarity Input Voltage 1.0% Duty Cycle, $\tau \leq 100$ ms	$-V_I(\tau)$	-50	Vpk
Switch/Reset Input Current	I_{in}	5.0	mA
Power Dissipation Case 314A, 314B and 314D (TO-220 Type) $T_A = 25^\circ\text{C}$ Thermal Resistance, Junction-to-Ambient Thermal Resistance, Junction-to-Case	P_D $R_{\theta JA}$ $R_{\theta JC}$	Internally Limited 65 5.0	W $^\circ\text{C/W}$ $^\circ\text{C/W}$
Case 936A (D ² PAK) $T_A = 25^\circ\text{C}$ Thermal Resistance, Junction-to-Ambient Thermal Resistance, Junction-to-Case	P_D $R_{\theta JA}$ $R_{\theta JC}$	Internally Limited Per Figure 1 5.0	W $^\circ\text{C/W}$ $^\circ\text{C/W}$
Operating Junction Temperature Range	T_J	-40 to +150	$^\circ\text{C}$
Storage Temperature Range	T_{stg}	-65 to +150	$^\circ\text{C}$

ELECTRICAL CHARACTERISTICS ($V_{in} = 14$ V, $I_O = 500$ mA, $I_{stby} = 0$ mA, $C_O = 10$ μF , $C_{stby} = 10$ μF , $T_J = 25^\circ\text{C}$ [Note 1].)

Characteristic	Symbol	Min	Typ	Max	Unit
MAIN OUTPUT					
Output Voltage ($V_{in} = 6.0$ V to 26 V, $I_O = 5.0$ mA to 500 mA, $T_J = -40$ to +125 $^\circ\text{C}$)	V_O	4.75	5.0	5.25	V
Line Regulation $V_{in} = 9.0$ V to 16 V, $I_O = 5.0$ mA $V_{in} = 6.0$ V to 26 V, $I_O = 5.0$ mA	Regline	-	4.0 10	25 50	mV
Load Regulation ($I_O = 5.0$ mA to 500 mA)	Regload	-	10	50	mV
Output Impedance $I_O = 500$ mA and 10 mArms, $f = 100$ Hz to 10 kHz	Z_O	-	200	-	$\text{m}\Omega$
Output Noise Voltage ($f = 10$ Hz to 100 kHz)	V_n	-	100	-	μV_{rms}
Long Term Stability	S	-	20	-	mV/kHR

LM2935

ELECTRICAL CHARACTERISTICS ($V_{in} = 14\text{ V}$, $I_O = 500\text{ mA}$, $I_{stby} = 0\text{ mA}$, $C_O = 10\text{ }\mu\text{F}$, $C_{stby} = 10\text{ }\mu\text{F}$, $T_J = 25^\circ\text{C}$ [Note 1].)

Characteristic	Symbol	Min	Typ	Max	Unit
MAIN OUTPUT (continued)					
Ripple Rejection ($f = 120\text{ Hz}$)	RR	–	66	–	dB
Dropout Voltage $I_O = 500\text{ mA}$ $I_O = 750\text{ mA}$	$V_I - V_O$	– –	0.45 0.82	0.6 –	V
Short Circuit Current Limit	I_{SC}	0.75	1.2	–	A
Over-Voltage Shutdown Threshold	$V_{th(OV)}$	26	31	–	V

SWITCH/RESET

Output Sink Current ($V_{OL} = 1.2\text{ V}$)	I_{Sink}	–	5.0	–	mA
Output Voltage ($R_{on/off} = 20\text{ k}\Omega$) Low State, $V_{in} = 4.0\text{ V}$ High State, $V_{in} = 14\text{ V}$	V_{OL} V_{OH}	– 4.5	0.9 5.0	1.2 6.0	V
Output Pull-Up Resistor, “On”/“Off” (Note 2)	$R_{on/off}$	–	20	30	$\text{k}\Omega$
Output Voltage with Reverse Polarity Input ($V_{in} = -15\text{ V}$, $R_L = 10\text{ }\Omega$)	$-V_O$	-0.6	0	–	V

ELECTRICAL CHARACTERISTICS ($V_{in} = 14\text{ V}$, $I_O = 0\text{ mA}$, $I_{stby} = 10\text{ mA}$, $C_O = 10\text{ }\mu\text{F}$, $C_{stby} = 10\text{ }\mu\text{F}$, $T_J = 25^\circ\text{C}$ [Note 1].)

Characteristic	Symbol	Min	Typ	Max	Unit
STANDBY OUTPUT					
Output Voltage ($V_{in} = 6.0\text{ V to } 26\text{ V}$, $I_{stby} = 1.0\text{ mA to } 10\text{ mA}$, $T_J = -40\text{ to } +125^\circ\text{C}$)	$V_{O(stby)}$	4.75	5.0	5.25	V
Tracking Voltage	$V_O - V_{O(stby)}$	-200	0	200	mV
Line Regulation ($V_{in} = 6.0\text{ V to } 26\text{ V}$)	Reg _{line}	–	4.0	50	mV
Load Regulation ($I_{stby} = 1.0\text{ mA to } 10\text{ mA}$)	Reg _{load}	–	10	50	mV
Output Impedance $I_{(stby)} = 10\text{ mAdc and } 1.0\text{ mArms}$, $f = 100\text{ Hz to } 10\text{ kHz}$	$Z_{O(stby)}$	–	1.0	–	Ω
Output Noise Voltage ($f = 10\text{ Hz to } 100\text{ kHz}$)	V_n	–	300	–	μVrms
Long Term Stability	S	–	20	–	mV/kHR
Ripple Rejection ($f = 120\text{ Hz}$)	RR	–	66	–	dB
Dropout Voltage ($I_{stby} = 10\text{ mA}$)	$V_I - V_{O(stby)}$	–	0.55	0.7	V
Short Circuit Current Limit	I_{SC}	25	70	–	mA
Output Voltage with Reverse Polarity Input $V_{in} = -15\text{ V}$, $R_L = 510\text{ }\Omega$	$-V_O$	-0.3	0	–	V
Output Voltage with Maximum Positive Input $V_{in} = 60\text{ V}$, $R_L = 510\text{ }\Omega$	$V_{O(max)}$	–	5.0	6.0	V

TOTAL DEVICE

Bias Current $I_O = 10\text{ mA}$, $I_{stby} = 0\text{ mA}$ $I_O = 500\text{ mA}$, $I_{stby} = 0\text{ mA}$ $I_O = 750\text{ mA}$, $I_{stby} = 0\text{ mA}$ Main Output “Off”, $I_{stby} = 10\text{ mA}$	I_B	– – – –	3.0 40 90 2.0	– 100 – 3.0	mA
---	-------	------------------	------------------------	----------------------	----

- NOTES:** 1. Low duty cycle pulse techniques are used during test to maintain junction temperature as close to ambient as possible.
2. The maximum switch/reset current must not exceed 5.0 mA.

LM2935

TYPICAL CIRCUIT WAVEFORMS

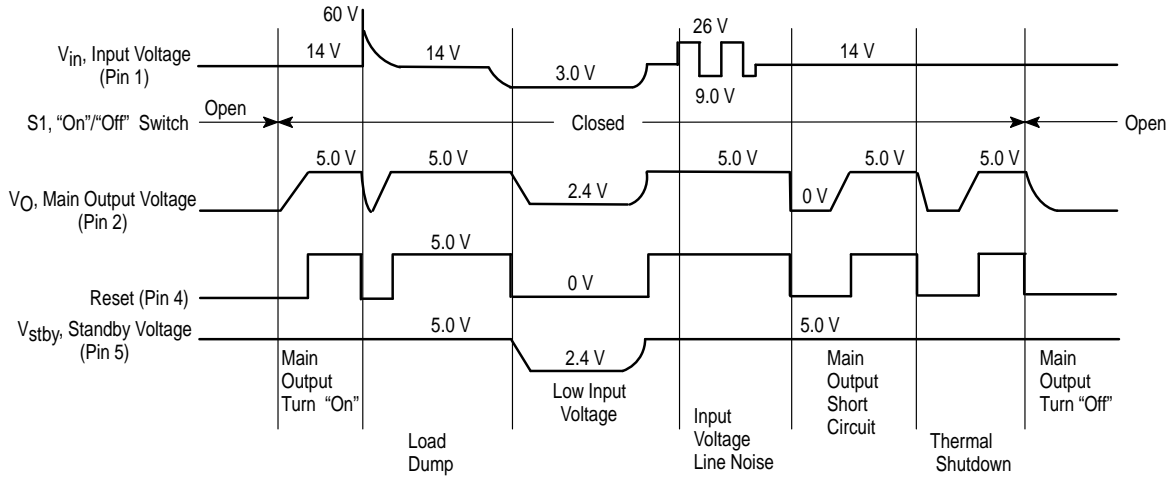
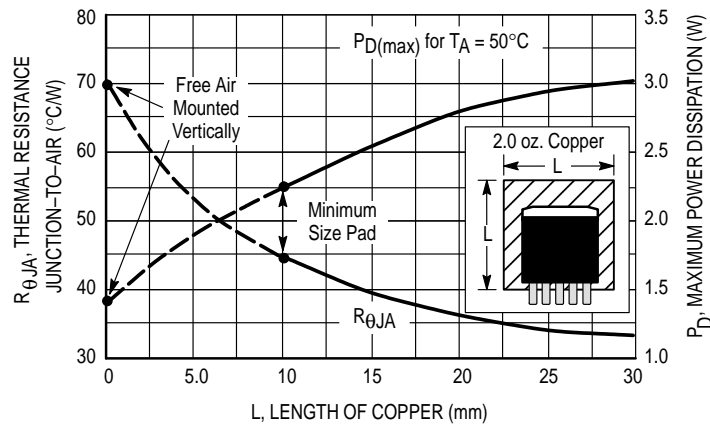

Figure 1. D²PAK Thermal Resistance and Maximum Power Dissipation versus P.C.B. Copper Length



LM2935

OUTLINE DIMENSIONS

TH SUFFIX PLASTIC PACKAGE CASE 314A-03 ISSUE D

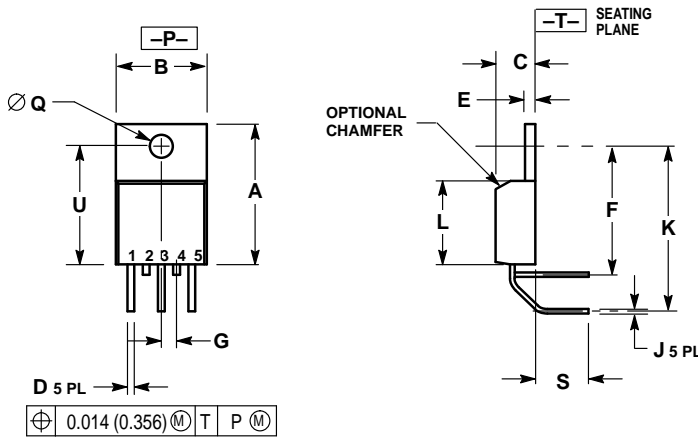

- NOTES:
1. DIMENSIONING AND TOLERANCING PER ANSI Y14.5M, 1982.
 2. CONTROLLING DIMENSION: INCH.
 3. DIMENSION D DOES NOT INCLUDE INTERCONNECT BAR (DAMBAR) PROTRUSION. DIMENSION D INCLUDING PROTRUSION SHALL NOT EXCEED 0.043 (1.092) MAXIMUM.

DIM	INCHES		MILLIMETERS	
	MIN	MAX	MIN	MAX
A	0.572	0.613	14.529	15.570
B	0.390	0.415	9.906	10.541
C	0.170	0.180	4.318	4.572
D	0.025	0.038	0.635	0.965
E	0.048	0.055	1.219	1.397
F	0.570	0.585	14.478	14.859
G	0.067 BSC		1.702 BSC	
J	0.015	0.025	0.381	0.635
K	0.730	0.745	18.542	18.923
L	0.320	0.365	8.128	9.271
Q	0.140	0.153	3.556	3.886
S	0.210	0.260	5.334	6.604
U	0.468	0.505	11.888	12.827

TV SUFFIX PLASTIC PACKAGE CASE 314B-05 ISSUE J

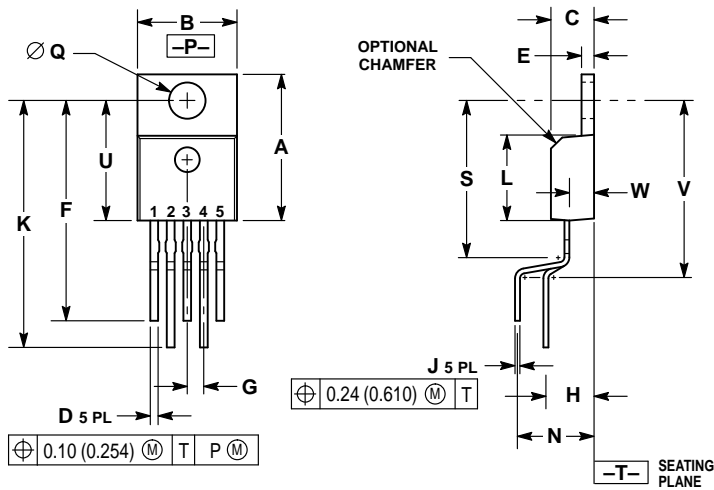

- NOTES:
1. DIMENSIONING AND TOLERANCING PER ANSI Y14.5M, 1982.
 2. CONTROLLING DIMENSION: INCH.
 3. DIMENSION D DOES NOT INCLUDE INTERCONNECT BAR (DAMBAR) PROTRUSION. DIMENSION D INCLUDING PROTRUSION SHALL NOT EXCEED 0.043 (1.092) MAXIMUM.

DIM	INCHES		MILLIMETERS	
	MIN	MAX	MIN	MAX
A	0.572	0.613	14.529	15.570
B	0.390	0.415	9.906	10.541
C	0.170	0.180	4.318	4.572
D	0.025	0.038	0.635	0.965
E	0.048	0.055	1.219	1.397
F	0.850	0.935	21.590	23.749
G	0.067 BSC		1.702 BSC	
H	0.166 BSC		4.216 BSC	
J	0.015	0.025	0.381	0.635
K	0.900	1.100	22.860	27.940
L	0.320	0.365	8.128	9.271
N	0.320 BSC		8.128 BSC	
Q	0.140	0.153	3.556	3.886
S	-	0.620	-	15.748
U	0.468	0.505	11.888	12.827
V	-	0.735	-	18.669
W	0.090	0.110	2.286	2.794

LM2935

OUTLINE DIMENSIONS

T SUFFIX PLASTIC PACKAGE CASE 314D-03 ISSUE D

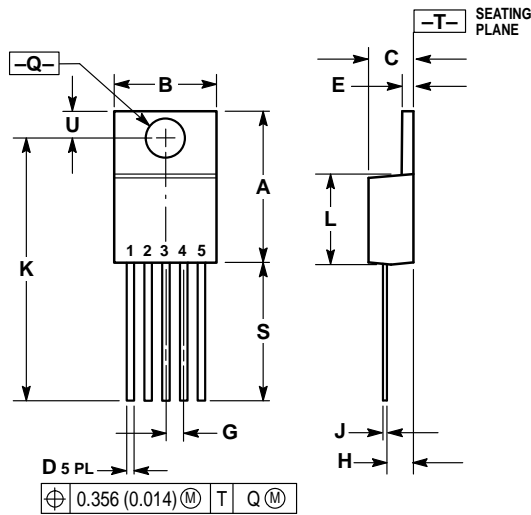

NOTES:

1. DIMENSIONING AND TOLERANCING PER ANSI Y14.5M, 1982.
2. CONTROLLING DIMENSION: INCH.
3. DIMENSION D DOES NOT INCLUDE INTERCONNECT BAR (DAMBAR) PROTRUSION. DIMENSION D INCLUDING PROTRUSION SHALL NOT EXCEED 10.92 (0.043) MAXIMUM.

DIM	INCHES		MILLIMETERS	
	MIN	MAX	MIN	MAX
A	0.572	0.613	14.529	15.570
B	0.390	0.415	9.906	10.541
C	0.170	0.180	4.318	4.572
D	0.025	0.038	0.635	0.965
E	0.048	0.055	1.219	1.397
G	0.067 BSC		1.702 BSC	
H	0.087	0.112	2.210	2.845
J	0.015	0.025	0.381	0.635
K	1.020	1.065	25.908	27.051
L	0.320	0.365	8.128	9.271
Q	0.140	0.153	3.556	3.886
U	0.105	0.117	2.667	2.972
S	0.543	0.582	13.792	14.783

D2T SUFFIX PLASTIC PACKAGE CASE 936A-02 (D²PAK) ISSUE A

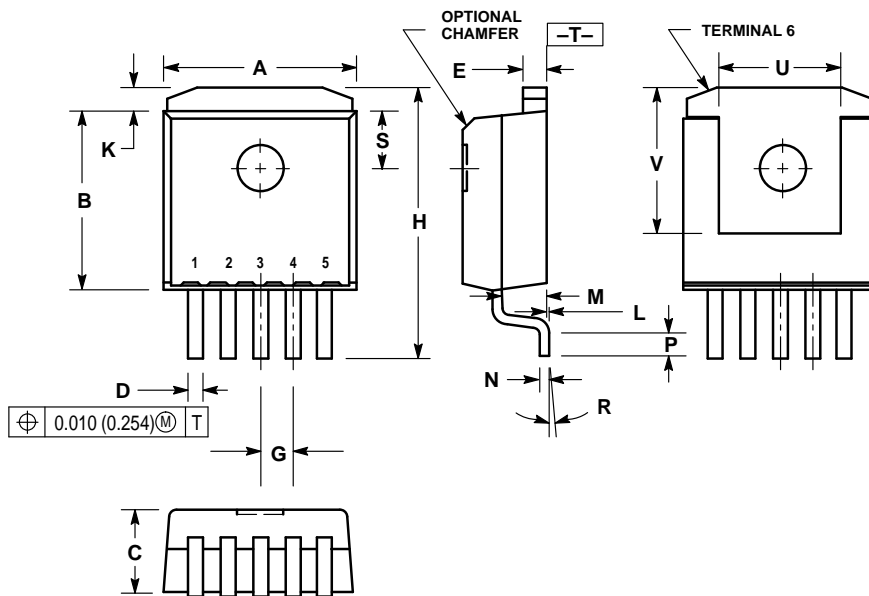

NOTES:

1. DIMENSIONING AND TOLERANCING PER ANSI Y14.5M, 1982.
2. CONTROLLING DIMENSION: INCH.
3. TAB CONTOUR OPTIONAL WITHIN DIMENSIONS A AND K.
4. DIMENSIONS U AND V ESTABLISH A MINIMUM MOUNTING SURFACE FOR TERMINAL 6.
5. DIMENSIONS A AND B DO NOT INCLUDE MOLD FLASH OR GATE PROTRUSIONS. MOLD FLASH AND GATE PROTRUSIONS NOT TO EXCEED 0.025 (0.635) MAXIMUM.

DIM	INCHES		MILLIMETERS	
	MIN	MAX	MIN	MAX
A	0.386	0.403	9.804	10.236
B	0.356	0.368	9.042	9.347
C	0.170	0.180	4.318	4.572
D	0.026	0.036	0.660	0.914
E	0.045	0.055	1.143	1.397
G	0.067 BSC		1.702 BSC	
H	0.539	0.579	13.691	14.707
K	0.050 REF		1.270 REF	
L	0.000	0.010	0.000	0.254
M	0.088	0.102	2.235	2.591
N	0.018	0.026	0.457	0.660
P	0.058	0.078	1.473	1.981
R	5° REF		5° REF	
S	0.116 REF		2.946 REF	
U	0.200 MIN		5.080 MIN	
V	0.250 MIN		6.350 MIN	

LM2935

Motorola reserves the right to make changes without further notice to any products herein. Motorola makes no warranty, representation or guarantee regarding the suitability of its products for any particular purpose, nor does Motorola assume any liability arising out of the application or use of any product or circuit, and specifically disclaims any and all liability, including without limitation consequential or incidental damages. "Typical" parameters which may be provided in Motorola data sheets and/or specifications can and do vary in different applications and actual performance may vary over time. All operating parameters, including "Typicals" must be validated for each customer application by customer's technical experts. Motorola does not convey any license under its patent rights nor the rights of others. Motorola products are not designed, intended, or authorized for use as components in systems intended for surgical implant into the body, or other applications intended to support or sustain life, or for any other application in which the failure of the Motorola product could create a situation where personal injury or death may occur. Should Buyer purchase or use Motorola products for any such unintended or unauthorized application, Buyer shall indemnify and hold Motorola and its officers, employees, subsidiaries, affiliates, and distributors harmless against all claims, costs, damages, and expenses, and reasonable attorney fees arising out of, directly or indirectly, any claim of personal injury or death associated with such unintended or unauthorized use, even if such claim alleges that Motorola was negligent regarding the design or manufacture of the part. Motorola and  are registered trademarks of Motorola, Inc. Motorola, Inc. is an Equal Opportunity/Affirmative Action Employer.

LM2935

How to reach us:

USA/EUROPE/Locations Not Listed: Motorola Literature Distribution;
P.O. Box 20912; Phoenix, Arizona 85036. 1-800-441-2447 or 602-303-5454

MFAX: RMFAX0@email.sps.mot.com – TOUCHTONE 602-244-6609
INTERNET: <http://Design-NET.com>

JAPAN: Nippon Motorola Ltd.; Tatsumi-SPD-JLDC, 6F Seibu-Butsuryu-Center,
3-14-2 Tatsumi Koto-Ku, Tokyo 135, Japan. 03-81-3521-8315

ASIA/PACIFIC: Motorola Semiconductors H.K. Ltd.; 8B Tai Ping Industrial Park,
51 Ting Kok Road, Tai Po, N.T., Hong Kong. 852-26629298



MOTOROLA



LM2935/D

