

LM317M

Three-Terminal Adjustable Output Positive Voltage Regulator

The LM317M is an adjustable three-terminal positive voltage regulator capable of supplying in excess of 500 mA over an output voltage range of 1.2 V to 37 V. This voltage regulator is exceptionally easy to use and requires only two external resistors to set the output voltage. Further, it employs internal current limiting, thermal shutdown and safe area compensation, making it essentially blow-out proof.

The LM317M serves a wide variety of applications including local, on-card regulation. This device also makes an especially simple adjustable switching regulator, a programmable output regulator, or by connecting a fixed resistor between the adjustment and output, the LM317M can be used as a precision current regulator.

- Output Current in Excess of 500 mA
- Output Adjustable between 1.2 V and 37 V
- Internal Thermal Overload Protection
- Internal Short Circuit Current Limiting
- Output Transistor Safe-Area Compensation
- Floating Operation for High Voltage Applications
- Eliminates Stocking Many Fixed Voltages

Simplified Application

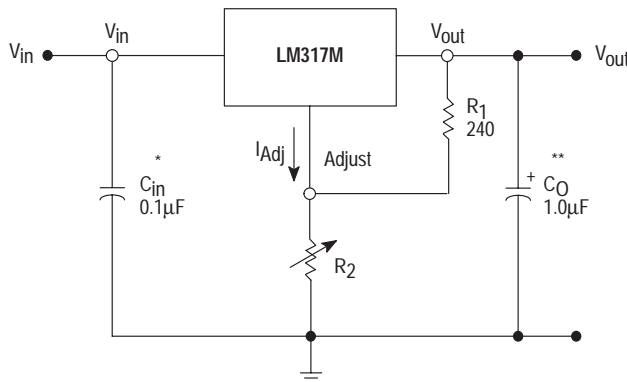

* = C_{in} is required if regulator is located an appreciable distance from power supply filter.
 ** = C_O is not needed for stability, however, it does improve transient response.

$$V_{out} = 1.25 \text{ V} \left(1 + \frac{R_2}{R_1} \right) + I_{Adj} R_2$$

Since I_{Adj} is controlled to less than 100 μA , the error associated with this term is negligible in most applications.



ON Semiconductor
 Formerly a Division of Motorola
<http://onsemi.com>

Heatsink surface
 connected to Pin 2

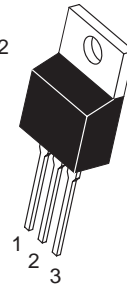

TO-220AB
T SUFFIX
CASE 221A



SOT-223
ST SUFFIX
CASE 318E

DPAK
DT SUFFIX
CASE 369A

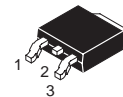

Heatsink Surface (shown as terminal 4 in case outline drawing) is connected to Pin 2.

PIN ASSIGNMENT	
1	Adjust
2	V_{out}
3	V_{in}

ORDERING INFORMATION

See detailed ordering and shipping information in the package dimensions section on page 10 of this data sheet.

LM317M

MAXIMUM RATINGS (T_A = 25°C, unless otherwise noted.)

Rating	Symbol	Value	Unit
Input–Output Voltage Differential	V _I –V _O	40	Vdc
Power Dissipation (Package Limitation) (Note 1)			
Plastic Package, T Suffix, Case 221A			
T _A = 25°C	P _D	Internally Limited	
Thermal Resistance, Junction–to–Air	θ _{JA}	70	°C/W
Thermal Resistance, Junction–to–Case	θ _{JC}	5.0	°C/W
Plastic Package, DT Suffix, Case 369A			
T _A = 25°C	P _D	Internally Limited	
Thermal Resistance, Junction–to–Air	θ _{JA}	92	°C/W
Thermal Resistance, Junction–to–Case	θ _{JC}	5.0	°C/W
Plastic Package, ST Suffix, Case 318E			
T _A = 25°C	P _D	Internally Limited	
Thermal Resistance, Junction–to–Air	θ _{JA}	245	°C/W
Thermal Resistance, Junction–to–Case	θ _{JC}	15	°C/W
Operating Junction Temperature Range	T _J	–40 to +125	°C
Storage Temperature Range	T _{stg}	–65 to +150	°C

NOTE: 1. Figure 23 provides thermal resistance versus pc board pad size.

ELECTRICAL CHARACTERISTICS (V_I–V_O = 5.0 V; I_O = 0.1 A, T_J = T_{low} to T_{high} [Note 1], unless otherwise noted.)

Characteristics	Figure	Symbol	Min	Typ	Max	Unit
Line Regulation (Note 2) T _A = 25°C, 3.0 V ≤ V _I –V _O ≤ 40 V	1	Reg _{line}	–	0.01	0.04	%/V
Load Regulation (Note 2) T _A = 25°C, 10 mA ≤ I _O ≤ 0.5 A V _O ≤ 5.0 V V _O ≥ 5.0 V	2	Reg _{load}	– –	5.0 0.1	25 0.5	mV % V _O
Adjustment Pin Current	3	I _{Adj}	–	50	100	μA
Adjustment Pin Current Change 2.5 V ≤ V _I –V _O ≤ 40 V, 10 mA ≤ I _L ≤ 0.5 A, P _D ≤ P _{max}	1,2	ΔI _{Adj}	–	0.2	5.0	μA
Reference Voltage 3.0 V ≤ V _I –V _O ≤ 40 V, 10 mA ≤ I _O ≤ 0.5 A, P _D ≤ P _{max} :	3	V _{ref}	1.200	1.250	1.300	V
Line Regulation (Note 2) 3.0 V ≤ V _I –V _O ≤ 40 V	1	Reg _{line}	–	0.02	0.07	%/V
Load Regulation (Note 2) 10 mA ≤ I _O ≤ 0.5 A V _O ≤ 5.0 V V _O ≥ 5.0 V	2	Reg _{load}	– –	20 0.3	70 1.5	mV % V _O
Temperature Stability (T _{low} ≤ T _J ≤ T _{high})	3	T _S	–	0.7	–	% V _O
Minimum Load Current to Maintain Regulation (V _I –V _O = 40 V)	3	I _{Lmin}	–	3.5	10	mA
Maximum Output Current V _I –V _O ≤ 15 V, P _D ≤ P _{max} V _I –V _O = 40 V, P _D ≤ P _{max} , T _A = 25°C	3	I _{max}	0.5 0.15	0.9 0.25	– –	A
RMS Noise, % of V _O T _A = 25°C, 10 Hz ≤ f ≤ 10 kHz	–	N	–	0.003	–	% V _O
Ripple Rejection, V _O = 10 V, f = 120 Hz (Note 3) Without C _{Adj} C _{Adj} = 10 μF	4	RR	– 66	65 80	– –	dB
Long–Term Stability, T _J = T _{high} (Note 4) T _A = 25°C for Endpoint Measurements	3	S	–	0.3	1.0	%/1.0 k Hrs.

- NOTES:** 1. T_{low} to T_{high} = 0° to +125°C for LM317M T_{low} to T_{high} = –40° to +125°C for LM317MB
2. Load and line regulation are specified at constant junction temperature. Changes in V_O due to heating effects must be taken into account separately. Pulse testing with low duty cycle is used.
3. C_{Adj}, when used, is connected between the adjustment pin and ground.
4. Since Long–Term Stability cannot be measured on each device before shipment, this specification is an engineering estimate of average stability from lot to lot.

LM317M

Representative Schematic Diagram

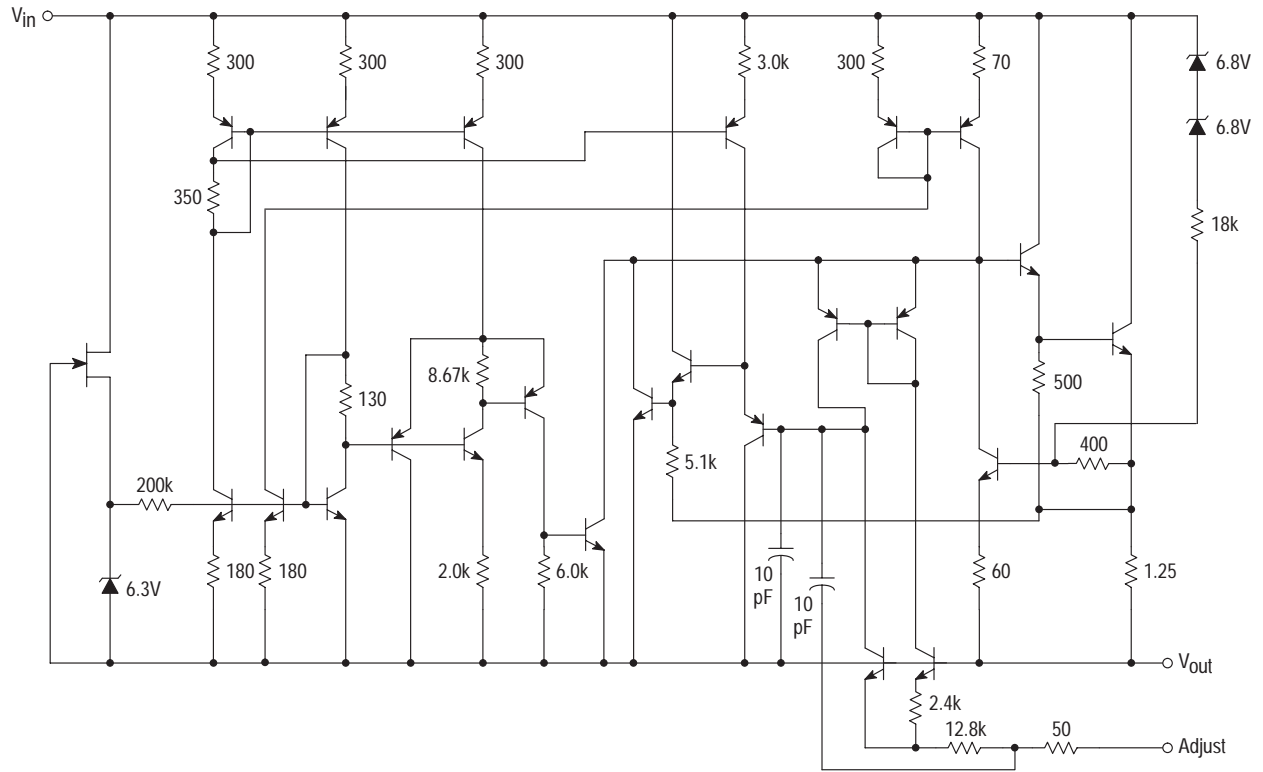

LM317M

Figure 1. Line Regulation and ΔI_{Adj} /Line Test Circuit

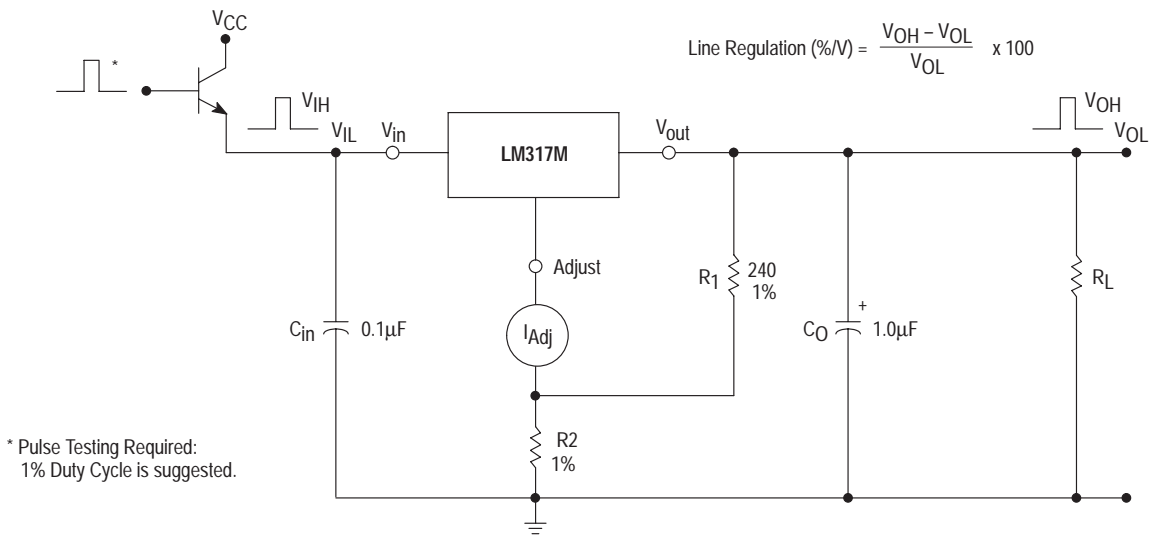
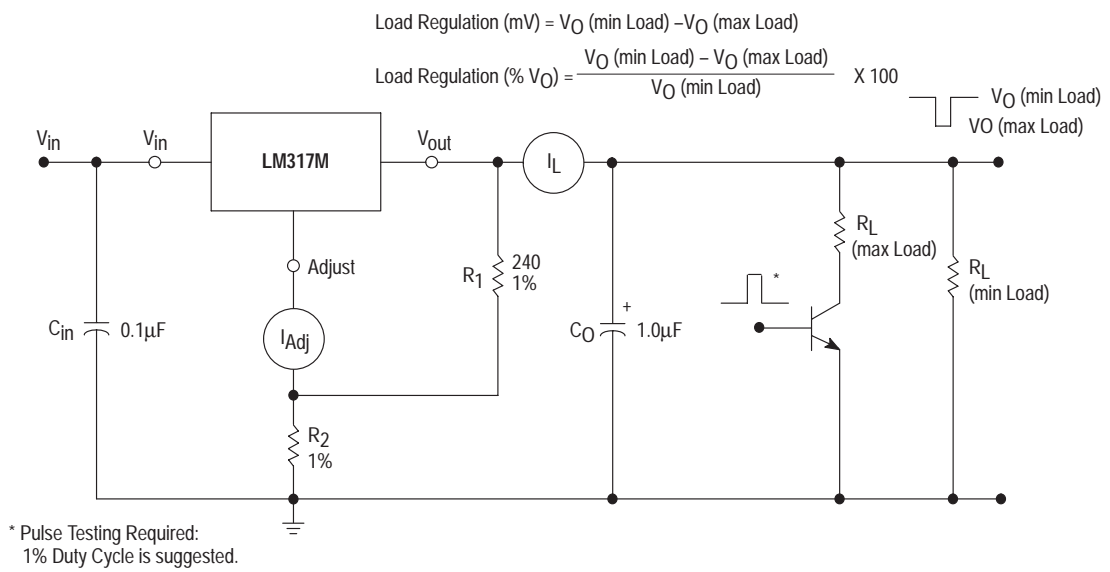
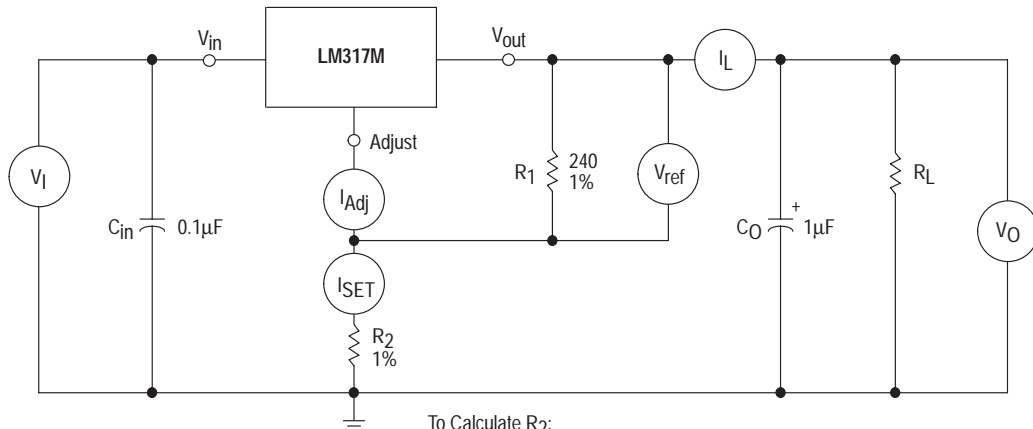

Figure 2. Load Regulation and ΔI_{Adj} /Load Test Circuit



LM317M

Figure 3. Standard Test Circuit



*Pulse Testing Required:
1% Duty Cycle is suggested.

To Calculate R_2 :
 $V_{out} = I_{SET} R_2 + 1.250 \text{ V}$
 Assume $I_{SET} = 5.25 \text{ mA}$

Figure 4. Ripple Rejection Test Circuit

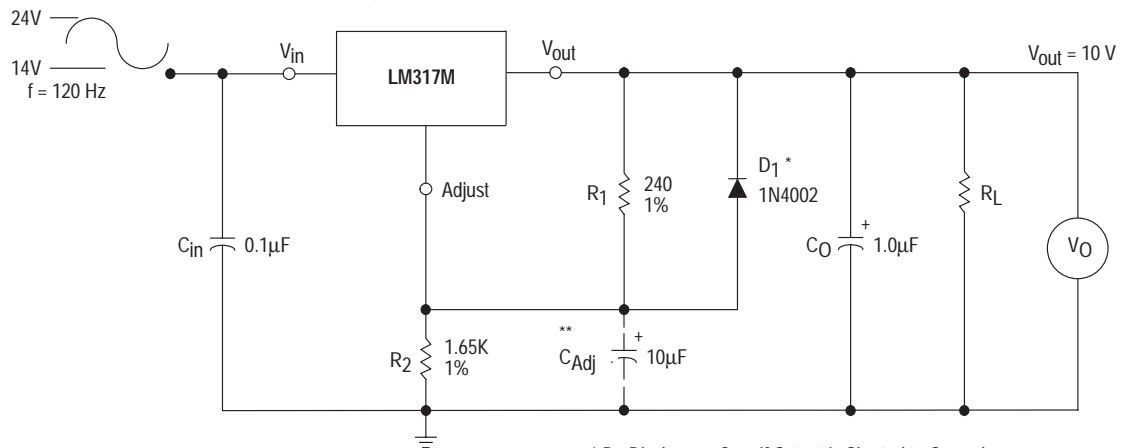

* D_1 Discharges C_{Adj} if Output is Shorted to Ground.
 ** C_{Adj} provides an AC ground to the adjust pin.

LM317M

Figure 5. Load Regulation

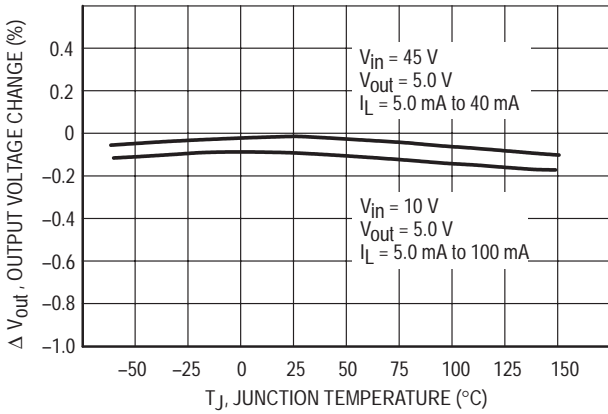

Figure 6. Ripple Rejection

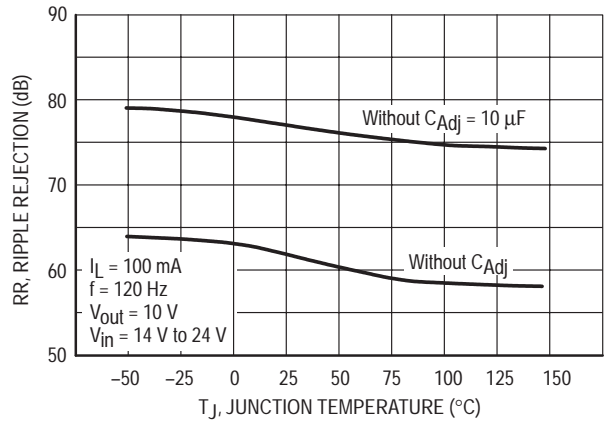

Figure 7. Current Limit

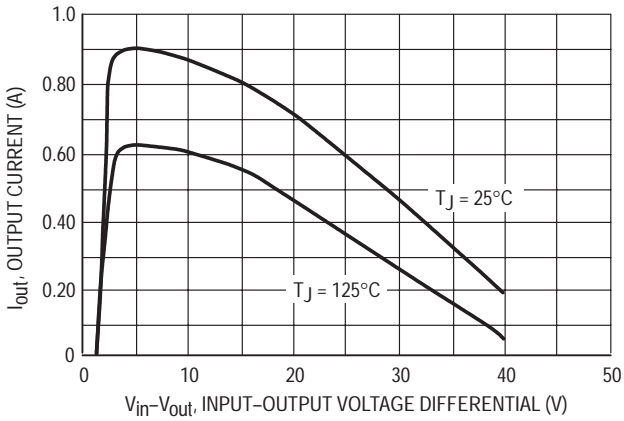

Figure 8. Dropout Voltage

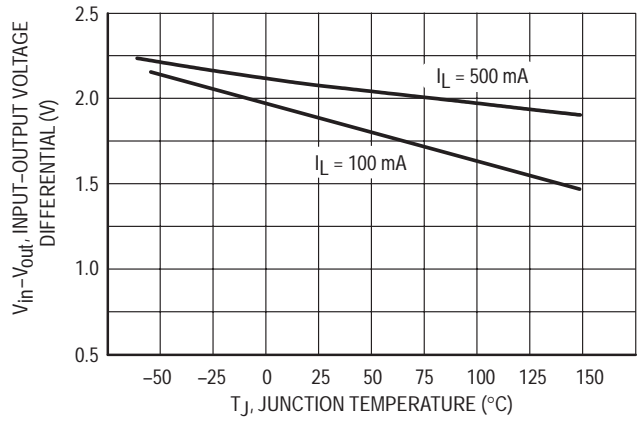

Figure 9. Minimum Operating Current

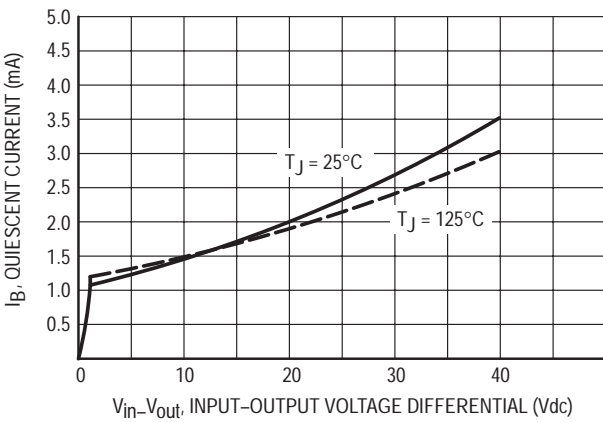
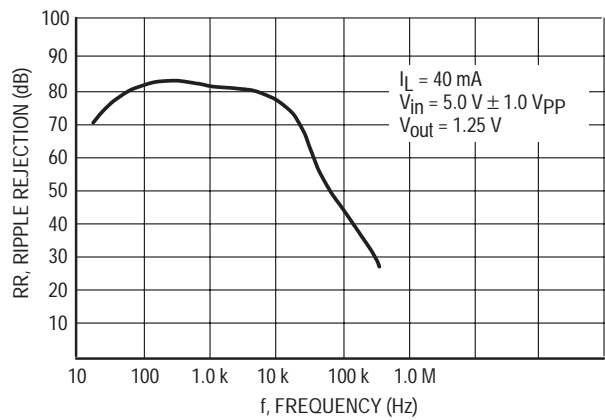

Figure 10. Ripple Rejection versus Frequency



LM317M

Figure 11. Temperature Stability

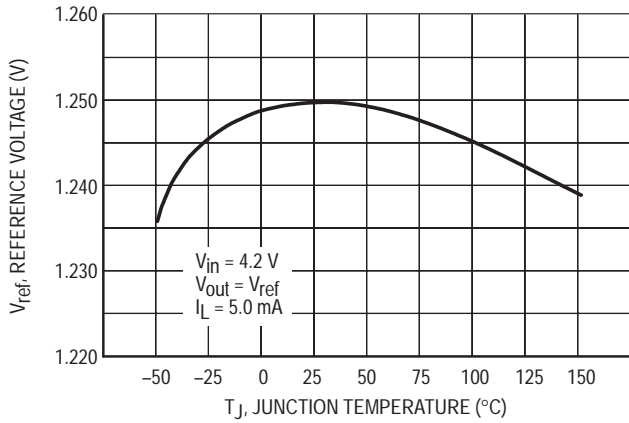

Figure 12. Adjustment Pin Current

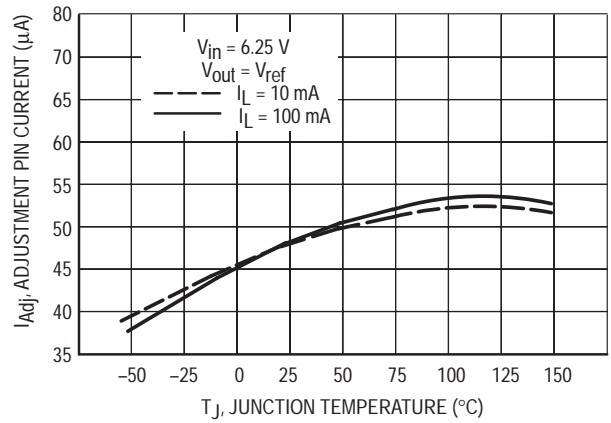

Figure 13. Line Regulation

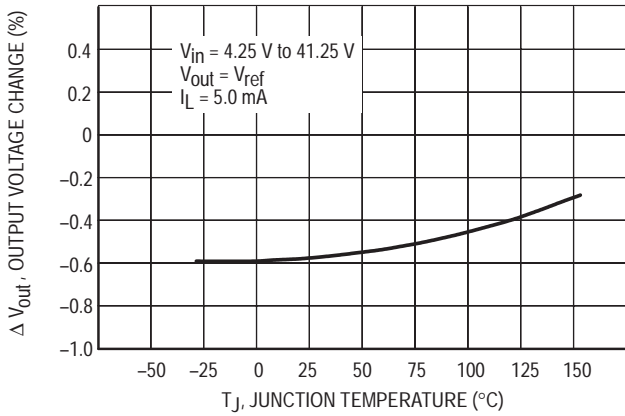

Figure 14. Output Noise

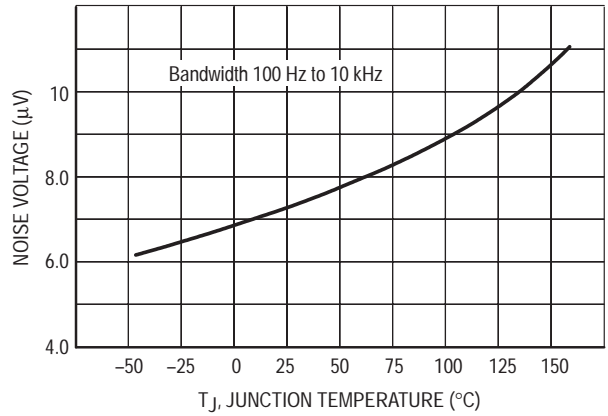

Figure 15. Line Transient Response

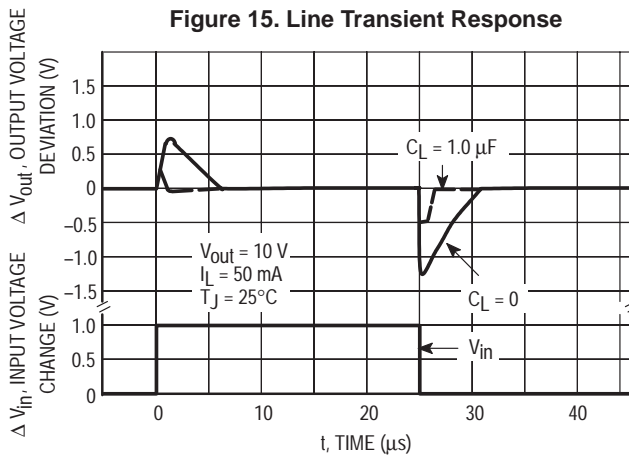
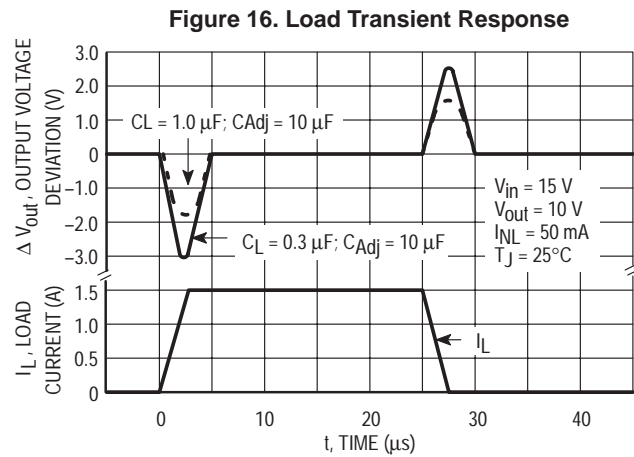

Figure 16. Load Transient Response



LM317M

APPLICATIONS INFORMATION

Basic Circuit Operation

The LM317M is a three-terminal floating regulator. In operation, the LM317M develops and maintains a nominal 1.25 V reference (V_{ref}) between its output and adjustment terminals. This reference voltage is converted to a programming current (I_{PROG}) by R_1 (see Figure 17), and this constant current flows through R_2 to ground. The regulated output voltage is given by:

$$V_{out} = V_{ref} \left(1 + \frac{R_2}{R_1} \right) + I_{Adj} R_2$$

Since the current from the terminal (I_{Adj}) represents an error term in the equation, the LM317M was designed to control I_{Adj} to less than 100 μA and keep it constant. To do this, all quiescent operating current is returned to the output terminal. This imposes the requirement for a minimum load current. If the load current is less than this minimum, the output voltage will rise.

Since the LM317M is a floating regulator, it is only the voltage differential across the circuit which is important to performance, and operation at high voltages with respect to ground is possible.

Figure 17. Basic Circuit Configuration

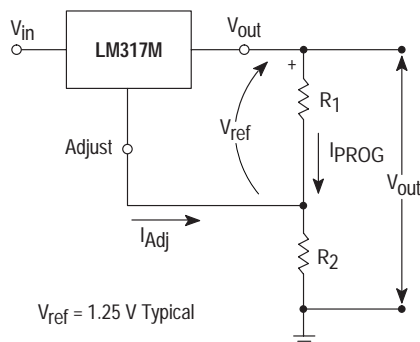

Load Regulation

The LM317M is capable of providing extremely good load regulation, but a few precautions are needed to obtain maximum performance. For best performance, the programming resistor (R_1) should be connected as close to the regulator as possible to minimize line drops which effectively appear in series with the reference, thereby degrading regulation. The ground end of R_2 can be returned near the load ground to provide remote ground sensing and improve load regulation.

External Capacitors

A 0.1 μF disc or 1.0 μF tantalum input bypass capacitor (C_{in}) is recommended to reduce the sensitivity to input line impedance.

The adjustment terminal may be bypassed to ground to improve ripple rejection. This capacitor (C_{Adj}) prevents ripple from being amplified as the output voltage is increased. A 10 μF capacitor should improve ripple rejection about 15 dB at 120 Hz in a 10 V application.

Although the LM317M is stable with no output capacitance, like any feedback circuit, certain values of external capacitance can cause excessive ringing. An output capacitance (C_O) in the form of a 1.0 μF tantalum or 25 μF aluminum electrolytic capacitor on the output swamps this effect and insures stability.

Protection Diodes

When external capacitors are used with any IC regulator it is sometimes necessary to add protection diodes to prevent the capacitors from discharging through low current points into the regulator.

Figure 18 shows the LM317M with the recommended protection diodes for output voltages in excess of 25 V or high capacitance values ($C_O > 25 \mu F$, $C_{Adj} > 5.0 \mu F$). Diode D_1 prevents C_O from discharging thru the IC during an input short circuit. Diode D_2 protects against capacitor C_{Adj} discharging through the IC during an output short circuit. The combination of diodes D_1 and D_2 prevents C_{Adj} from discharging through the IC during an input short circuit.

Figure 18. Voltage Regulator with Protection Diodes

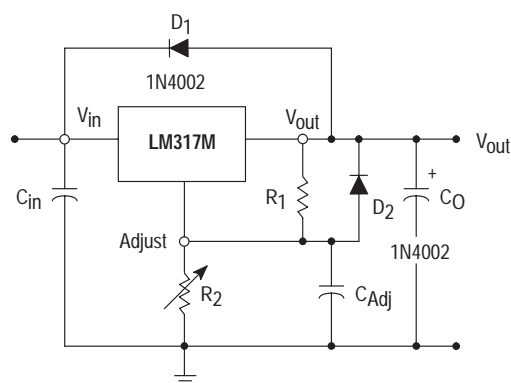

LM317M

Figure 19. Adjustable Current Limiter

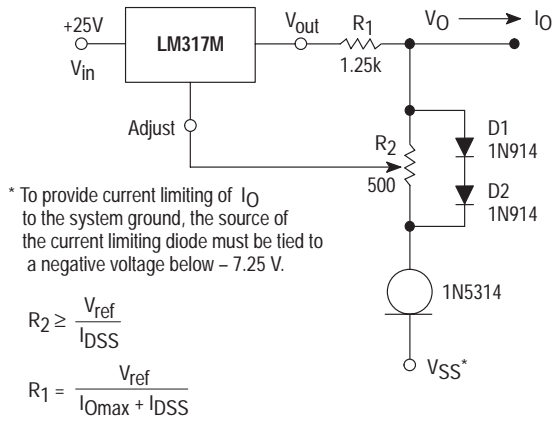

$V_O < P_{OV} + 1.25$ V + V_{SS}
 $I_{Lmin} - I_p < I_O < 500$ mA - I_p
 As shown $0 < I_O < 495$ mA

Figure 20. 5 V Electronic Shutdown Regulator

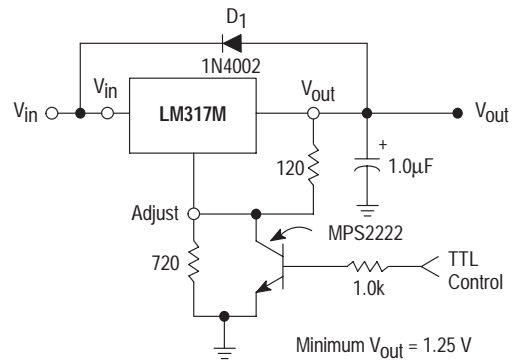

D1 protects the device during an input short circuit.

Figure 21. Slow Turn-On Regulator

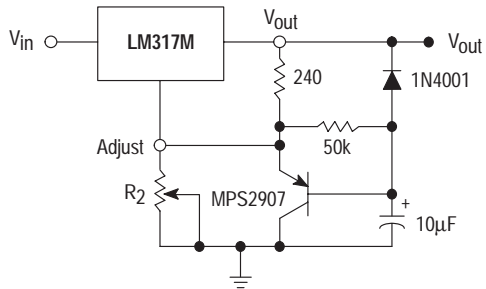

Figure 22. Current Regulator

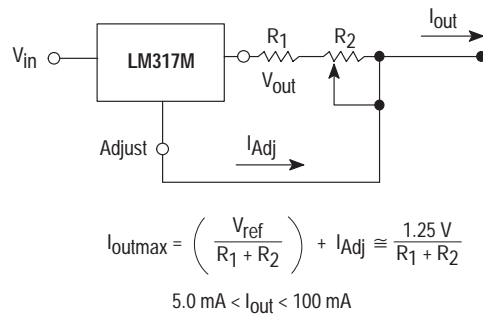

Figure 23. DPAK Thermal Resistance and Maximum Power Dissipation versus P.C.B. Copper Length

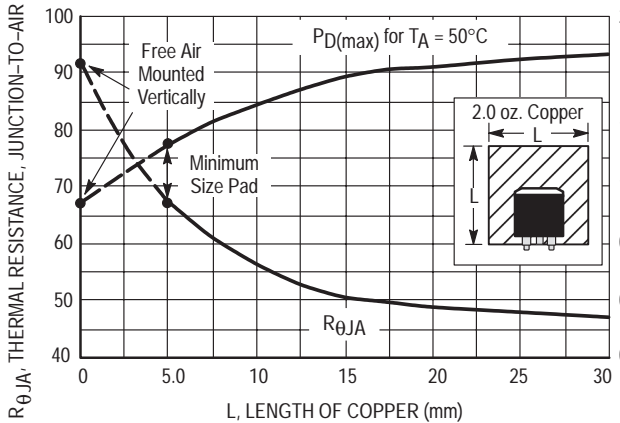
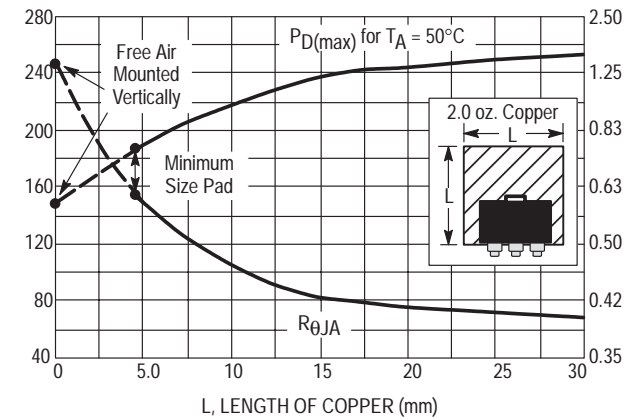

Figure 24. SOT-223 Thermal Resistance and Maximum Power Dissipation versus P.C.B. Copper Length



LM317M

ORDERING INFORMATION

Device	Operating Temperature Range	Package	Shipping
LM317MT	$T_J = 0^\circ\text{C to } 125^\circ\text{C}$	TO-220	50 units/rail
LM317MDT	$T_J = 0^\circ\text{C to } 125^\circ\text{C}$	DPAK	75 units/rail
LM317MDTRK	$T_J = 0^\circ\text{C to } 125^\circ\text{C}$	DPAK	2500 units/Tape & Reel
LM317MSTT3	$T_J = 0^\circ\text{C to } 125^\circ\text{C}$	SOT-223	4000 units/Tape & Reel
LM317MBT	$T_J = -40^\circ\text{C to } 125^\circ\text{C}$	TO-220	50 units/rail
LM317MBDT	$T_J = -40^\circ\text{C to } 125^\circ\text{C}$	DPAK	75 units/rail
LM317MBDTRK	$T_J = -40^\circ\text{C to } 125^\circ\text{C}$	DPAK	2500 units/Tape & Reel
LM317MBSTT3	$T_J = -40^\circ\text{C to } 125^\circ\text{C}$	SOT-223	4000 units/Tape & Reel

PACKAGE DIMENSIONS

T SUFFIX PLASTIC PACKAGE CASE 221A-09 ISSUE Z

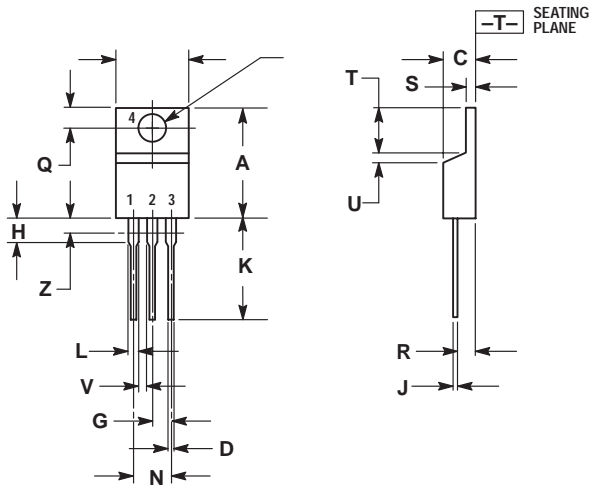

- NOTES:
- DIMENSIONING AND TOLERANCING PER ANSI Y14.5M, 1982.
 - CONTROLLING DIMENSION: INCH.
 - DIMENSION Z DEFINES A ZONE WHERE ALL BODY AND LEAD IRREGULARITIES ARE ALLOWED.

DIM	INCHES		MILLIMETERS	
	MIN	MAX	MIN	MAX
A	0.570	0.620	14.48	15.75
B	0.380	0.405	9.66	10.28
C	0.160	0.190	4.07	4.82
D	0.025	0.035	0.64	0.88
F	0.142	0.147	3.61	3.73
G	0.095	0.105	2.42	2.66
H	0.110	0.155	2.80	3.93
J	0.018	0.025	0.46	0.64
K	0.500	0.562	12.70	14.27
L	0.045	0.060	1.15	1.52
N	0.190	0.210	4.83	5.33
Q	0.100	0.120	2.54	3.04
R	0.080	0.110	2.04	2.79
S	0.045	0.055	1.15	1.39
T	0.235	0.255	5.97	6.47
U	0.000	0.050	0.00	1.27
V	0.045	---	1.15	---
Z	---	0.080	---	2.04

(SOT-223) ST SUFFIX PLASTIC PACKAGE CASE 318E-04 ISSUE J

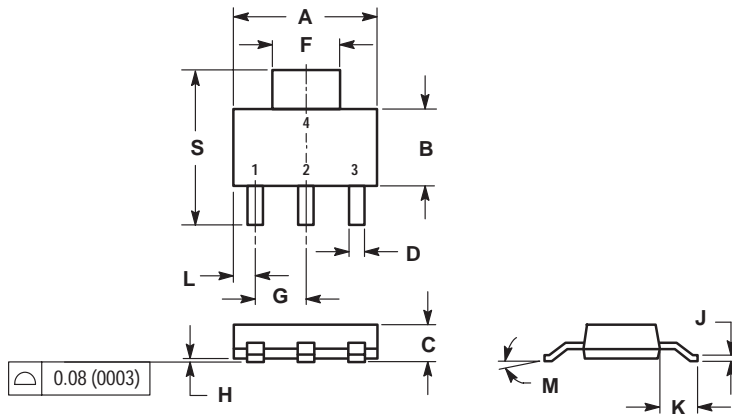

- NOTES:
- DIMENSIONING AND TOLERANCING PER ANSI Y14.5M, 1982.
 - CONTROLLING DIMENSION: INCH.

DIM	INCHES		MILLIMETERS	
	MIN	MAX	MIN	MAX
A	0.249	0.263	6.30	6.70
B	0.130	0.145	3.30	3.70
C	0.060	0.068	1.50	1.75
D	0.024	0.035	0.60	0.89
F	0.115	0.126	2.90	3.20
G	0.087	0.094	2.20	2.40
H	0.0008	0.0040	0.020	0.100
J	0.009	0.014	0.24	0.35
K	0.060	0.078	1.50	2.00
L	0.033	0.041	0.85	1.05
M	0°	10°	0°	10°
S	0.264	0.287	6.70	7.30

LM317M

PACKAGE DIMENSIONS

(DPAK)
DT SUFFIX
PLASTIC PACKAGE
CASE 369A-13
ISSUE Z

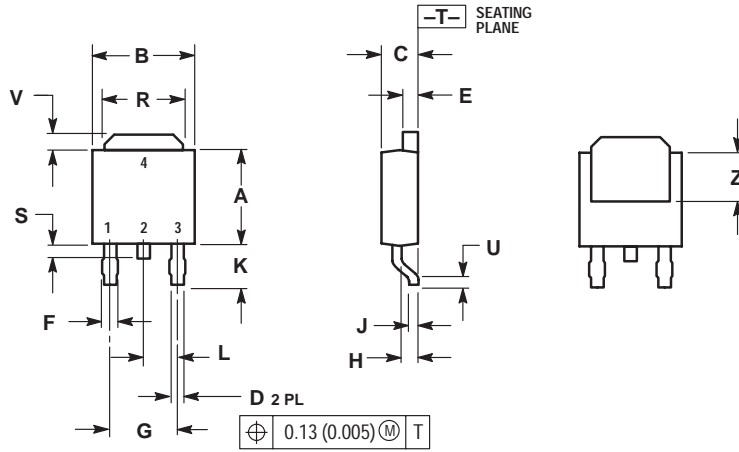

- NOTES:
1. DIMENSIONING AND TOLERANCING PER ANSI Y14.5M, 1982.
2. CONTROLLING DIMENSION: INCH.

DIM	INCHES		MILLIMETERS	
	MIN	MAX	MIN	MAX
A	0.235	0.250	5.97	6.35
B	0.250	0.265	6.35	6.73
C	0.086	0.094	2.19	2.38
D	0.027	0.035	0.69	0.88
E	0.033	0.040	0.84	1.01
F	0.037	0.047	0.94	1.19
G	0.180 BSC		4.58 BSC	
H	0.034	0.040	0.87	1.01
J	0.018	0.023	0.46	0.58
K	0.102	0.114	2.60	2.89
L	0.090 BSC		2.29 BSC	
R	0.175	0.215	4.45	5.46
S	0.020	0.050	0.51	1.27
U	0.020	---	0.51	---
V	0.030	0.050	0.77	1.27
Z	0.138	---	3.51	---

LM317M

ON Semiconductor and  are trademarks of Semiconductor Components Industries, LLC (SCILLC). SCILLC reserves the right to make changes without further notice to any products herein. SCILLC makes no warranty, representation or guarantee regarding the suitability of its products for any particular purpose, nor does SCILLC assume any liability arising out of the application or use of any product or circuit, and specifically disclaims any and all liability, including without limitation special, consequential or incidental damages. "Typical" parameters which may be provided in SCILLC data sheets and/or specifications can and do vary in different applications and actual performance may vary over time. All operating parameters, including "Typicals" must be validated for each customer application by customer's technical experts. SCILLC does not convey any license under its patent rights nor the rights of others. SCILLC products are not designed, intended, or authorized for use as components in systems intended for surgical implant into the body, or other applications intended to support or sustain life, or for any other application in which the failure of the SCILLC product could create a situation where personal injury or death may occur. Should Buyer purchase or use SCILLC products for any such unintended or unauthorized application, Buyer shall indemnify and hold SCILLC and its officers, employees, subsidiaries, affiliates, and distributors harmless against all claims, costs, damages, and expenses, and reasonable attorney fees arising out of, directly or indirectly, any claim of personal injury or death associated with such unintended or unauthorized use, even if such claim alleges that SCILLC was negligent regarding the design or manufacture of the part. SCILLC is an Equal Opportunity/Affirmative Action Employer.

PUBLICATION ORDERING INFORMATION

USA/EUROPE Literature Fulfillment:

Literature Distribution Center for ON Semiconductor
P.O. Box 5163, Denver, Colorado 80217 USA
Phone: 303-675-2175 or 800-344-3860 Toll Free USA/Canada
Fax: 303-675-2176 or 800-344-3867 Toll Free USA/Canada
Email: ONlit@hibbertco.com

Fax Response Line*: 303-675-2167
800-344-3810 Toll Free USA/Canada
*To receive a Fax of our publications

N. America Technical Support: 800-282-9855 Toll Free USA/Canada

ASIA/PACIFIC: LDC for ON Semiconductor – Asia Support

Phone: 303-675-2121 (Tue–Fri 9:00am to 1:00pm, Hong Kong Time)
Email: ONlit-asia@hibbertco.com

JAPAN: ON Semiconductor, Japan Customer Focus Center
4-32-1 Nishi-Gotanda, Shinagawa-ku, Tokyo, Japan 141-8549
Phone: 81-3-5487-8345
Email: r14153@onsemi.com

ON Semiconductor Website: <http://onsemi.com>

For additional information, please contact your local Sales Representative.