

Universal Hexadecimal Counter

The MC10136 is a high speed synchronous counter that can count up, count down, preset, or stop count at frequencies exceeding 100 MHz. The flexibility of this device allows the designer to use one basic counter for most applications, and the synchronous count feature makes the MC10136 suitable for either computers or instrumentation.

Three control lines (S1, S2, and Carry In) determine the operation mode of the counter. Lines S1 and S2 determine one of four operations; preset (program), increment (count up), decrement (count down), or hold (stop count). Note that in the preset mode a clock pulse is necessary to load the counter, and the information present on the data inputs (D0, D1, D2, and D3) will be entered into the counter. Carry Out goes low on the terminal count, or when the counter is being preset.

This device is not designed for use with gated clocks. Control is via S1 and S2.

MC10136

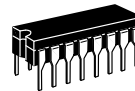

L SUFFIX
CERAMIC PACKAGE
CASE 620-10



P SUFFIX
PLASTIC PACKAGE
CASE 648-08



FN SUFFIX
PLCC
CASE 775-02

$P_D = 625 \text{ mW typ/pkg (No Load)}$
 $f_{\text{count}} = 150 \text{ MHz typ}$
 $t_{pd} = 3.3 \text{ ns typ (C-Q)}$
 $7.0 \text{ ns typ (C-C}_{\text{out}})$
 $5.0 \text{ ns typ (C}_{\text{in}}\text{-C}_{\text{out}})$

FUNCTION TABLE

C _{in}	S1	S2	Operating Mode
X	L	L	Preset (Program)
L	L	H	Increment (Count Up)
H	L	H	Hold Count
L	H	L	Decrement (Count Down)
H	H	L	Hold Count
X	H	H	Hold (Stop Count)

DIP PIN ASSIGNMENT

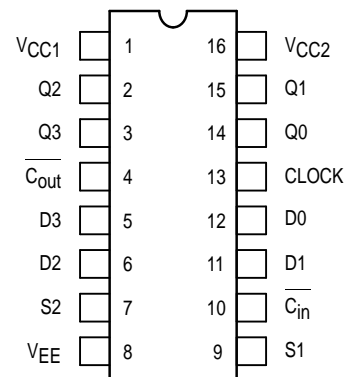

Pin assignment is for Dual-in-Line Package. For PLCC pin assignment, see the Pin Conversion Tables on page 6-11 of the Motorola MECL Data Book (DL122/D).



LOGIC DIAGRAM

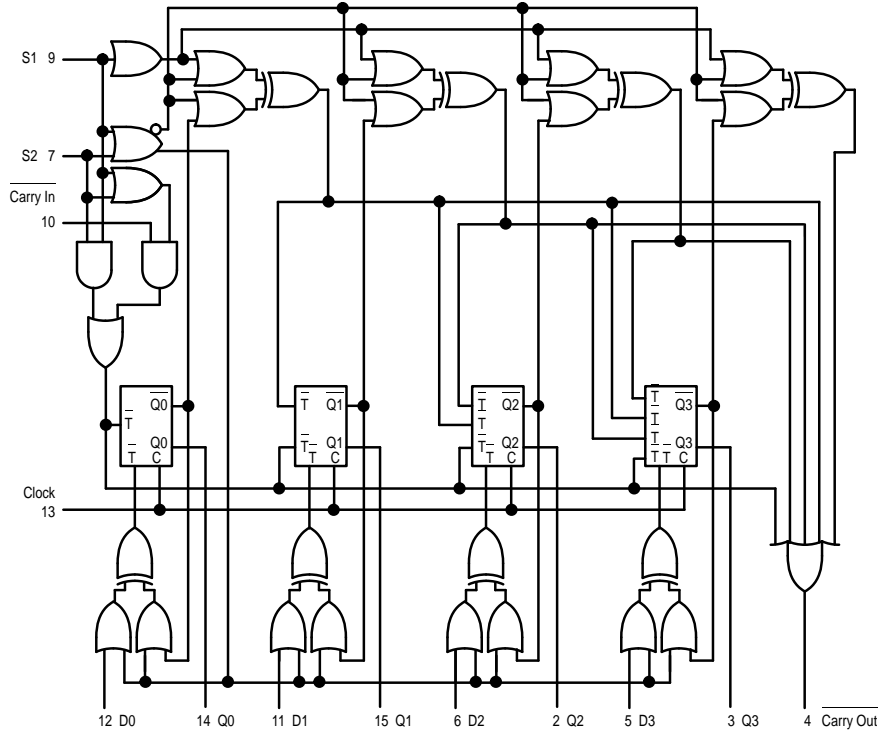

VCC1 = PIN 1
 VCC2 = PIN 16
 VEE = PIN 8

NOTE: Flip-flops will toggle when all T inputs are low.

SEQUENTIAL TRUTH TABLE*

INPUTS								OUTPUTS				
S1	S2	D0	D1	D2	D3	Carry In	Clock **	Q0	Q1	Q2	Q3	Carry Out
L	L	L	L	H	H	X	H	L	L	H	H	L
L	H	X	X	X	X	L	H	H	L	H	H	H
L	H	X	X	X	X	L	H	L	H	H	H	H
L	H	X	X	X	X	L	H	H	H	H	H	L
L	H	X	X	X	X	H	L	H	H	H	H	H
L	H	X	X	X	X	H	H	H	H	H	H	H
L	H	X	X	X	X	X	H	H	H	H	H	H
L	H	X	X	X	X	X	H	H	H	H	H	H
H	L	X	X	X	X	L	H	L	H	L	L	H
H	L	X	X	X	X	L	H	H	L	L	L	H
H	L	X	X	X	X	L	H	L	L	L	L	L
H	L	X	X	X	X	L	H	H	H	H	H	H

* Truth table shows logic states assuming inputs vary in sequence shown from top to bottom.
 ** A clock H is defined as a clock input transition from a low to a high logic level.

ELECTRICAL CHARACTERISTICS

Characteristic	Symbol	Pin Under Test	Test Limits						Unit		
			-30°C		+25°C			+85°C			
			Min	Max	Min	Typ	Max	Min		Max	
Power Supply Drain Current	I_E	8		138		100	125		138	mAdc	
Input Current	I_{inH}	5,6,11,12		350			220		220	μ Adc	
		7		425			265		265		
		9,10		390			245		245		
		13		460			290		290		
	I_{inL}	All	0.5		0.5			0.3		μ Adc	
Output Voltage	Logic 1	V_{OH}	14 (2.)	-1.060	-0.890	-0.960		-0.810	-0.890	-0.700	Vdc
Output Voltage	Logic 0	V_{OL}	14 (2.)	-1.890	-1.675	-1.850		-1.650	-1.825	-1.615	Vdc
Threshold Voltage	Logic 1	V_{OHA}	14 (2.)	-1.080		-0.980			-0.910		Vdc
Threshold Voltage	Logic 0	V_{OLA}	14 (2.)		-1.655			-1.630		-1.595	Vdc
Switching Times	(50 Ω Load)										ns
Propagation Delay	Clock Input	t_{13+14+}	14	0.8	4.8	1.0	3.3	4.5	1.4	5.0	
		t_{13+14-}	14	0.8	4.8	1.0	3.3	4.5	1.4	5.0	
		t_{13+4+}	4	2.0	10.9	2.5	7.0	10.5	2.4	11.5	
		t_{13+4-}	4	2.0	10.9	2.5	7.0	10.5	2.4	11.5	
Carry In to Carry Out		t_{10-4-}	4 (3.)	1.6	7.4	1.6	5.0	6.9	1.9	7.5	
		t_{10+4+}	4	1.6	7.4	1.6	5.0	6.9	1.9	7.5	
Setup Time	Data Inputs	t_{12+13+}	14	3.5		3.5			3.5		
		t_{12-13+}	14	3.5		3.5			3.5		
	Select Inputs	t_{9+13+}	14	6.0		6.0			6.0		
		t_{7+13+}	14	6.0		6.0			6.0		
Carry In Input		t_{10-13+}	14	2.5		2.5			3.0		
		t_{10+13+}	14	1.5		1.5			1.5		
Hold Time	Data Inputs	t_{13+12+}	14	0		0			0		
		t_{13+12-}	14	0		0			0		
	Select Inputs	t_{13+9+}	14	-1.0		-1.0			-1.0		
		t_{13+7+}	14	-1.0		-1.0			-1.0		
Carry In Input		t_{13+10-}	14	0		0			0		
		t_{13+10+}	14	0		0			0		
Counting Frequency		$f_{countup}$	14	125		125	150		125		MHz
		$f_{countdown}$	14	125		125	150		125		
Rise Time	(20 to 80%)	t_{4+}	4	0.9	3.3	1.1	2.0	3.3	1.1	3.5	ns
		t_{14+}	14	0.9	3.3	1.1	2.0	3.3	1.1	3.5	
Fall Time	(20 to 80%)	t_{4-}	4	0.9	3.3	1.1	2.0	3.3	1.1	3.5	ns
		t_{14-}	14	0.9	3.3	1.1	2.0	3.3	1.1	3.5	

1. Individually test each input; apply V_{ILmin} to pin under test.

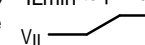
2. Measure output after clock pulse V_{IL}  V_{IH} appears at clock input (Pin 13).

3. Before test set all Q outputs to a logic high.

4. To preserve reliable performance, the MC10136 (plastic packaged device only) is to be operated in ambient temperatures above 70°C only when 500lfpm blown air or equivalent heat sinking is provided.

ELECTRICAL CHARACTERISTICS (continued)

			TEST VOLTAGE VALUES (Volts)						
			V _{IHmax}	V _{ILmin}	V _{IHAmin}	V _{ILAmx}	V _{EE}		
@ Test Temperature									
			-30°C	-0.890	-1.890	-1.205	-1.500	-5.2	
			+25°C	-0.810	-1.850	-1.105	-1.475	-5.2	
			+85°C	-0.700	-1.825	-1.035	-1.440	-5.2	
Characteristic	Symbol	Pin Under Test	TEST VOLTAGE APPLIED TO PINS LISTED BELOW					(V _{CC}) Gnd	
			V _{IHmax}	V _{ILmin}	V _{IHAmin}	V _{ILAmx}	V _{EE}		
Power Supply Drain Current	I _E	8					8	1, 16	
Input Current	I _{inH}	5,6,11,12	5,6,11,12				8	1, 16	
		7	7			8	1, 16		
		9,10	9,10			8	1, 16		
		13	13			8	1, 16		
	I _{inL}	All		Note 1.			8	1, 16	
Output Voltage	Logic 1	V _{OH}	14 (2.)	12	7, 9		8	1, 16	
Output Voltage	Logic 0	V _{OL}	14 (2.)		7, 9		8	1, 16	
Threshold Voltage	Logic 1	V _{OHA}	14 (2.)		7, 9	12	8	1, 16	
Threshold Voltage	Logic 0	V _{OLA}	14 (2.)		7, 9	12	8	1, 16	
Switching Times	(50Ω Load)			+1.11V	+0.31V	Pulse In	Pulse Out	-3.2 V	+2.0 V
Propagation Delay	Clock Input	t ₁₃₊₁₄₊	14	12		13	14	8	1, 16
		t ₁₃₊₁₄₋	14			13	14	8	1, 16
		t ₁₃₊₄₊	4	7		13	4	8	1, 16
		t ₁₃₊₄₋	4	7		13	4	8	1, 16
Carry In to Carry Out		t ₁₀₋₄₋	4 (3.)	7	13	10	4	8	1, 16
		t ₁₀₊₄₊	4	7	13	10	4	8	1, 16
Setup Time	Data Inputs	t ₁₂₊₁₃₊	14		7, 9	12, 13	14	8	1, 16
		t ₁₂₋₁₃₊	14		7, 9	12, 13	14	8	1, 16
	Select Inputs	t ₉₊₁₃₊	14			9, 13	14	8	1, 16
		t ₇₊₁₃₊	14			7, 13	14	8	1, 16
Carry In Inputs	t ₁₀₋₁₃₊	14	7	9	10, 13	14	8	1, 16	
	t ₁₀₊₁₃₊	14	7	9	10, 13	14	8	1, 16	
Hold Time	Data Inputs	t ₁₃₊₁₂₊	14		7, 9	12, 13	14	8	1, 16
		t ₁₃₊₁₂₋	14		7, 9	12, 13	14	8	1, 16
	Select Inputs	t ₁₃₊₉₊	14			9, 13	14	8	1, 16
		t ₁₃₊₇₊	14			7, 13	14	8	1, 16
Carry In Inputs	t ₁₃₊₁₀₋	14	7	9	10, 13	14	8	1, 16	
	t ₁₃₊₁₀₊	14	7		10, 13	14	8	1, 16	
Counting Frequency		f _{countup}	14	7		13	14	8	1, 16
		f _{countdown}	14	9		13	14	8	1, 16
Rise Time	(20 to 80%)	t ₄₊	4	7		13	4	8	1, 16
		t ₁₄₊	14	7		13	14	8	1, 16
Fall Time	(20 to 80%)	t ₄₋	4	7		13	4	8	1, 16
		t ₁₄₋	14	7		13	14	8	1, 16

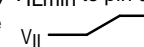
1. Individually test each input; apply V_{ILmin} to pin under test.
2. Measure output after clock pulse  V_{IH} appears at clock input (Pin 13).
3. Before test set all Q outputs to a logic high.
4. To preserve reliable performance, the MC10136 (plastic packaged device only) is to be operated in ambient temperatures above 70°C only when 500fpm blown air or equivalent heat sinking is provided.

Each MECL 10,000 series circuit has been designed to meet the dc specifications shown in the test table, after thermal equilibrium has been established. The circuit is in a test socket or mounted on a printed circuit board and transverse air flow greater than 500 linear fpm is maintained. Outputs are terminated through a 50-ohm resistor to -2.0 volts. Test procedures are shown for only one gate. The other gates are tested in the same manner.

SWITCHING TIME TEST CIRCUIT AND WAVEFORMS @ 25°C

NOTE:

t_{setup} is the minimum time before the positive transition of the clock pulse (C) that information must be present at the input D or S.

t_{hold} is the minimum time after the positive transition of the clock pulse (C) that information must remain unchanged at the input D or S.

INPUT PULSE

$$T+ = T- = 2.0 \pm 0.2 \text{ NS} \\ (20 \text{ TO } 80\%)$$

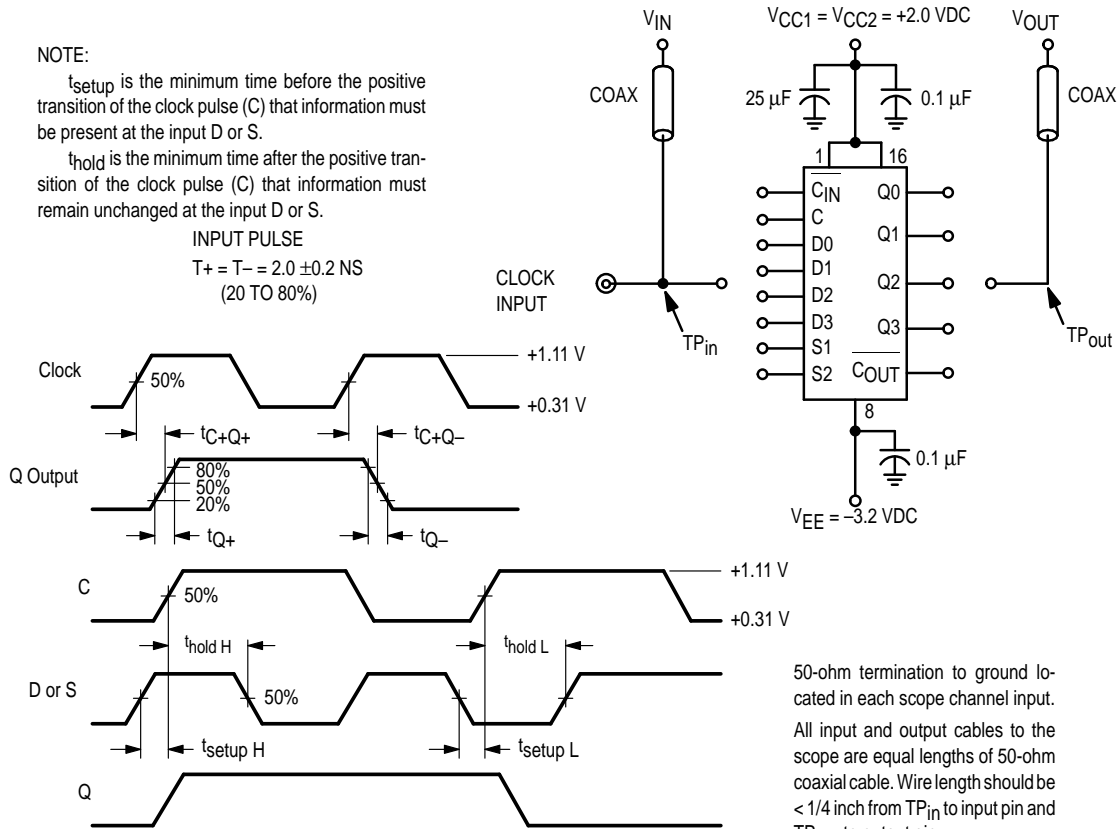

50-ohm termination to ground located in each scope channel input. All input and output cables to the scope are equal lengths of 50-ohm coaxial cable. Wire length should be < 1/4 inch from TP_{in} to input pin and TP_{out} to output pin. Unused outputs are connected to a 50-ohm resistor to ground.

CARRY IN SET UP AND HOLD TIMES

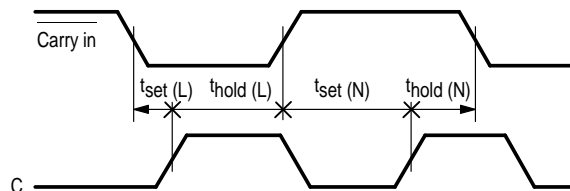

APPLICATIONS INFORMATION

To provide more than four bits of counting capability several MC10136 counters may be cascaded. The Carry In input overrides the clock when the counter is either in the increment mode or the decrement mode of operation. This input allows several devices to be cascaded in a fully synchronous multistage counter as illustrated in Figure 1. The carry is advanced between stages as shown with no external gating. The Carry In of the first device may be left open. The system clock is common to all devices.

The various operational modes of the counter make it useful for a wide variety of applications. If used with MECL III devices, prescalers with input toggle frequencies in excess of 300 MHz are possible. Figure 2 shows such a prescaler using the MC10136 and MC1670. Use of the MC10231 in place of the MC1670 permits 200 MHz operation.

The MC10136 may also be used as a programmable counter. The configuration of Figure 3 requires no additional gates, although maximum frequency is limited to about 50 MHz. The divider modulus is equal to the program input plus one ($M = N + 1$), therefore, the counter will divide by a modulus varying from 1 to 16.

A second programmable configuration is also illustrated in Figure 4. A pulse swallowing technique is used to speed the counter operation up to 110 MHz typically. The divider modulus for this figure is equal to the program input ($M = N$). The minimum modulus is 2 because of the pulse swallowing technique, and the modulus may vary from 2 to 15. This programmable configuration requires an additional gate, such as $1/2$ MC10109 and a flip-flop such as $1/2$ MC10131.

FIGURE 1 — 12 BIT SYNCHRONOUS COUNTER

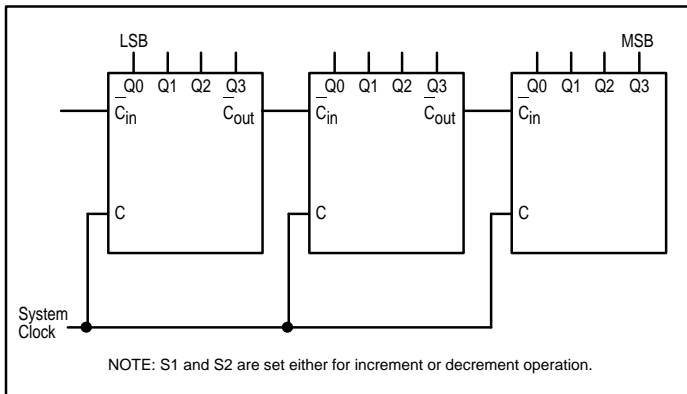

FIGURE 2 — 300 MHz PRESCALER

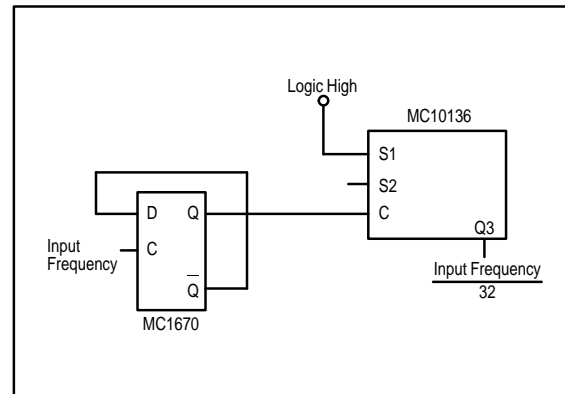

FIGURE 3 — 50 MHz PROGRAMMABLE COUNTER

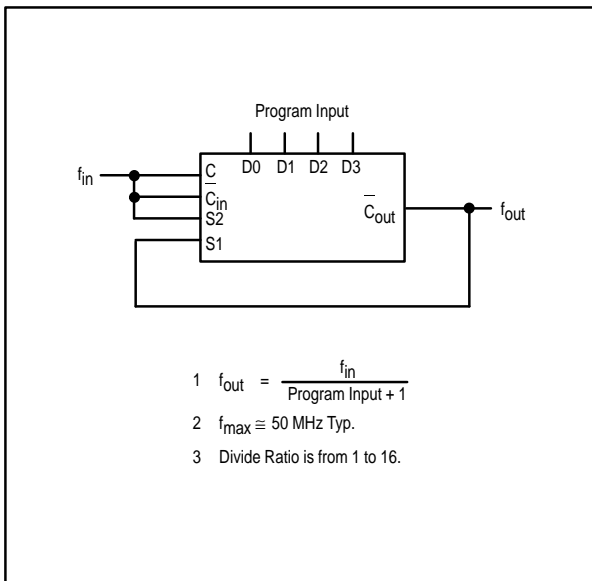
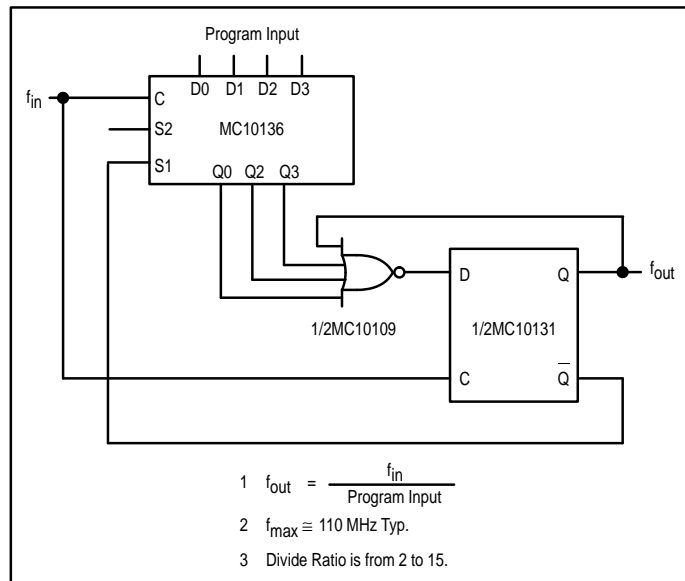
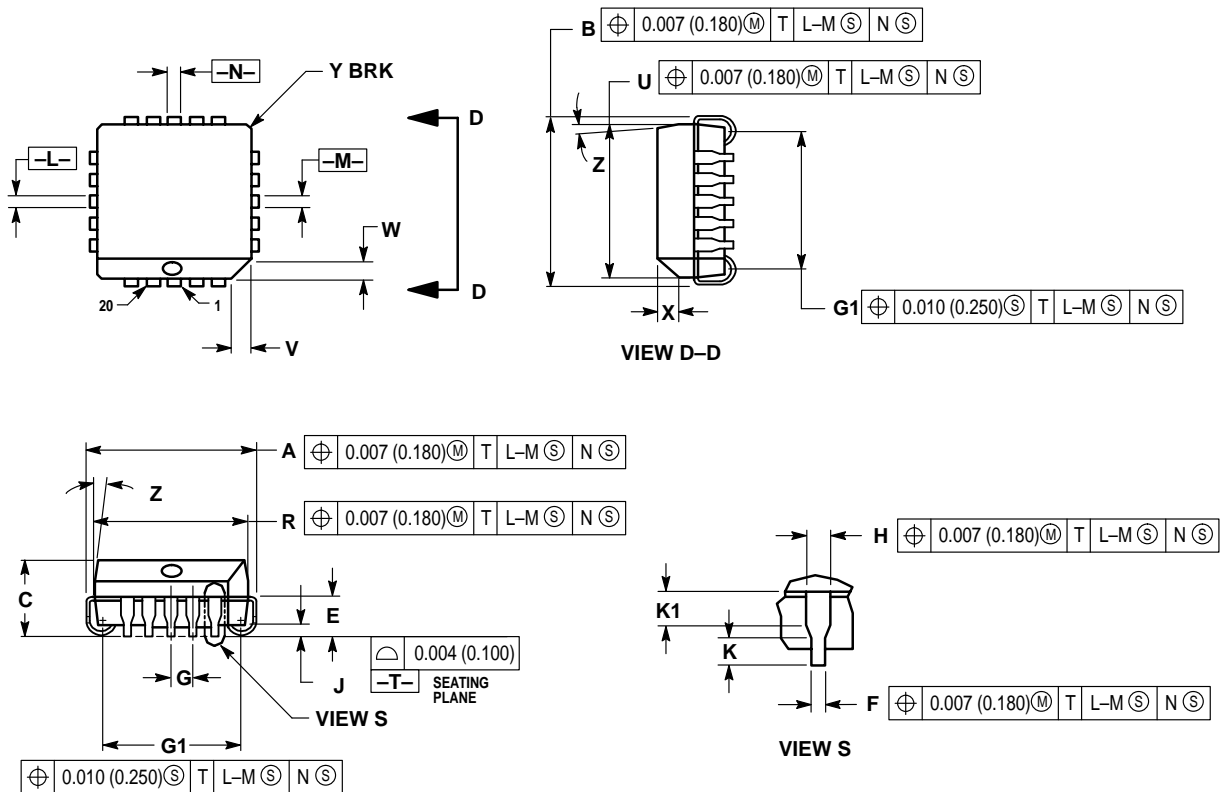

FIGURE 4 — 100 MHz PROGRAMMABLE COUNTER



OUTLINE DIMENSIONS

FN SUFFIX
 PLASTIC PLCC PACKAGE
 CASE 775-02
 ISSUE C



- NOTES:
- DATUMS -L-, -M-, AND -N- DETERMINED WHERE TOP OF LEAD SHOULDER EXITS PLASTIC BODY AT MOLD PARTING LINE.
 - DIMENSION G1, TRUE POSITION TO BE MEASURED AT DATUM -T-, SEATING PLANE.
 - DIMENSIONS R AND U DO NOT INCLUDE MOLD FLASH. ALLOWABLE MOLD FLASH IS 0.010 (0.250) PER SIDE.
 - DIMENSIONING AND TOLERANCING PER ANSI Y14.5M, 1982.
 - CONTROLLING DIMENSION: INCH.
 - THE PACKAGE TOP MAY BE SMALLER THAN THE PACKAGE BOTTOM BY UP TO 0.012 (0.300). DIMENSIONS R AND U ARE DETERMINED AT THE OUTERMOST EXTREMES OF THE PLASTIC BODY EXCLUSIVE OF MOLD FLASH, TIE BAR BURRS, GATE BURRS AND INTERLEAD FLASH, BUT INCLUDING ANY MISMATCH BETWEEN THE TOP AND BOTTOM OF THE PLASTIC BODY.
 - DIMENSION H DOES NOT INCLUDE DAMBAR PROTRUSION OR INTRUSION. THE DAMBAR PROTRUSION(S) SHALL NOT CAUSE THE H DIMENSION TO BE GREATER THAN 0.037 (0.940). THE DAMBAR INTRUSION(S) SHALL NOT CAUSE THE H DIMENSION TO BE SMALLER THAN 0.025 (0.635).

DIM	INCHES		MILLIMETERS	
	MIN	MAX	MIN	MAX
A	0.385	0.395	9.78	10.03
B	0.385	0.395	9.78	10.03
C	0.165	0.180	4.20	4.57
E	0.090	0.110	2.29	2.79
F	0.013	0.019	0.33	0.48
G	0.050 BSC		1.27 BSC	
H	0.026	0.032	0.66	0.81
J	0.020	—	0.51	—
K	0.025	—	0.64	—
R	0.350	0.356	8.89	9.04
U	0.350	0.356	8.89	9.04
V	0.042	0.048	1.07	1.21
W	0.042	0.048	1.07	1.21
X	0.042	0.056	1.07	1.42
Y	—	0.020	—	0.50
Z	2° 10°		2° 10°	
G1	0.310	0.330	7.88	8.38
K1	0.040	—	1.02	—

OUTLINE DIMENSIONS

L SUFFIX
CERAMIC DIP PACKAGE
CASE 620-10
ISSUE V

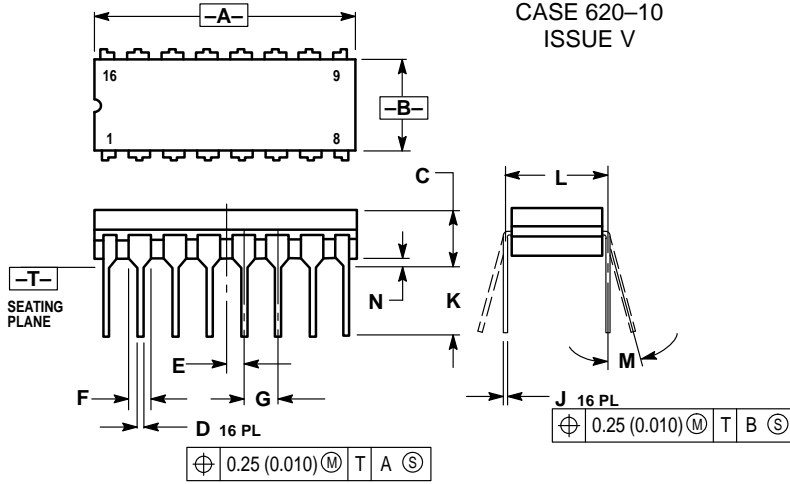

- NOTES:
1. DIMENSIONING AND TOLERANCING PER ANSI Y14.5M, 1982.
 2. CONTROLLING DIMENSION: INCH.
 3. DIMENSION L TO CENTER OF LEAD WHEN FORMED PARALLEL.
 4. DIMENSION F MAY NARROW TO 0.76 (0.030) WHERE THE LEAD ENTERS THE CERAMIC BODY.

DIM	INCHES		MILLIMETERS	
	MIN	MAX	MIN	MAX
A	0.750	0.785	19.05	19.93
B	0.240	0.295	6.10	7.49
C	—	0.200	—	5.08
D	0.015	0.020	0.39	0.50
E	0.050 BSC		1.27 BSC	
F	0.055	0.065	1.40	1.65
G	0.100 BSC		2.54 BSC	
H	0.008	0.015	0.21	0.38
K	0.125	0.170	3.18	4.31
L	0.300 BSC		7.62 BSC	
M	0°		15°	
N	0.020	0.040	0.51	1.01

P SUFFIX
PLASTIC DIP PACKAGE
CASE 648-08
ISSUE R

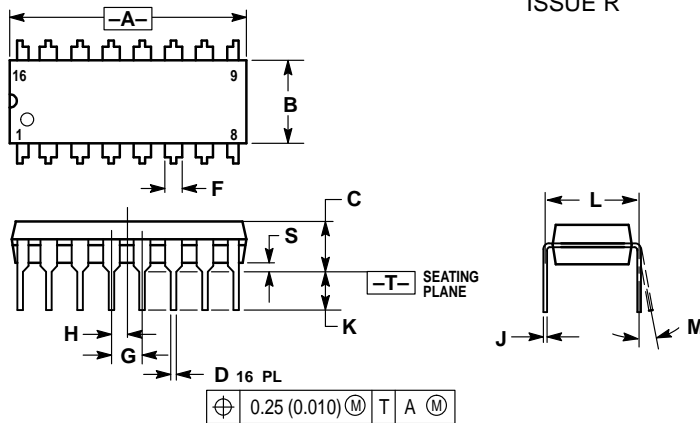

- NOTES:
1. DIMENSIONING AND TOLERANCING PER ANSI Y14.5M, 1982.
 2. CONTROLLING DIMENSION: INCH.
 3. DIMENSION L TO CENTER OF LEADS WHEN FORMED PARALLEL.
 4. DIMENSION B DOES NOT INCLUDE MOLD FLASH.
 5. ROUNDED CORNERS OPTIONAL.

DIM	INCHES		MILLIMETERS	
	MIN	MAX	MIN	MAX
A	0.740	0.770	18.80	19.55
B	0.250	0.270	6.35	6.85
C	0.145	0.175	3.69	4.44
D	0.015	0.021	0.39	0.53
F	0.040	0.70	1.02	1.77
G	0.100 BSC		2.54 BSC	
H	0.050 BSC		1.27 BSC	
J	0.008	0.015	0.21	0.38
K	0.110	0.130	2.80	3.30
L	0.295	0.305	7.50	7.74
M	0°		10°	
S	0.020	0.040	0.51	1.01

Motorola reserves the right to make changes without further notice to any products herein. Motorola makes no warranty, representation or guarantee regarding the suitability of its products for any particular purpose, nor does Motorola assume any liability arising out of the application or use of any product or circuit, and specifically disclaims any and all liability, including without limitation consequential or incidental damages. "Typical" parameters which may be provided in Motorola data sheets and/or specifications can and do vary in different applications and actual performance may vary over time. All operating parameters, including "Typicals" must be validated for each customer application by customer's technical experts. Motorola does not convey any license under its patent rights nor the rights of others. Motorola products are not designed, intended, or authorized for use as components in systems intended for surgical implant into the body, or other applications intended to support or sustain life, or for any other application in which the failure of the Motorola product could create a situation where personal injury or death may occur. Should Buyer purchase or use Motorola products for any such unintended or unauthorized application, Buyer shall indemnify and hold Motorola and its officers, employees, subsidiaries, affiliates, and distributors harmless against all claims, costs, damages, and expenses, and reasonable attorney fees arising out of, directly or indirectly, any claim of personal injury or death associated with such unintended or unauthorized use, even if such claim alleges that Motorola was negligent regarding the design or manufacture of the part. Motorola and are registered trademarks of Motorola, Inc. Motorola, Inc. is an Equal Opportunity/Affirmative Action Employer.

How to reach us:

USA/EUROPE/Locations Not Listed: Motorola Literature Distribution; P.O. Box 5405, Denver, Colorado 80217. 303-675-2140 or 1-800-441-2447

Mfax™: RMFAX0@email.sps.mot.com – TOUCHTONE 602-244-6609
INTERNET: <http://Design-NET.com>

JAPAN: Nippon Motorola Ltd.; Tatsumi-SPD-JLDC, 6F Seibu-Butsuryu-Center, 3-14-2 Tatsumi Koto-Ku, Tokyo 135, Japan. 81-3-3521-8315

ASIA/PACIFIC: Motorola Semiconductors H.K. Ltd.; 8B Tai Ping Industrial Park, 51 Ting Kok Road, Tai Po, N.T., Hong Kong. 852-26629298

