

68030/040 PECL-TTL Clock Driver

The MC10H/100H644 generates the necessary clocks for the 68030, 68040 and similar microprocessors. The device is functionally equivalent to the H640, but with fewer outputs in a smaller outline 20-lead PLCC package. It is guaranteed to meet the clock specifications required by the 68030 and 68040 in terms of part-to-part skew, within-part skew and also duty cycle skew.

- Generates Clocks for 68030/040
- Meets 68030/040 Skew Requirements
- TTL or PECL Input Clock
- Extra TTL and ECL Power/Ground Pins
- Within Device Skew on Similar Paths is 0.5 ns
- Asynchronous Reset
- Single +5.0V Supply

The user has a choice of using either TTL or PECL (ECL referenced to +5.0V) for the input clock. TTL clocks are typically used in present MPU systems. However, as clock speeds increase to 50MHz and beyond, the inherent superiority of ECL (particularly differential ECL) as a means of clock signal distribution becomes increasingly evident. The H644 also uses differential ECL internally to achieve its superior skew characteristic.

The H644 includes divide-by-two and divide-by-four stages, both to achieve the necessary duty cycle and skew to generate MPU clocks as required. A typical 50MHz processor application would use an input clock running at 100MHz, thus obtaining output clocks at 50MHz and 25MHz (see Logic Symbol).

The 10H version is compatible with MECL 10H™ ECL logic levels, while the 100H version is compatible with 100K levels (referenced to +5.0V).

Function

Reset (R): LOW on RESET forces all Q outputs LOW and all \bar{Q} outputs HIGH.

Synchronized Outputs: The device is designed to have the POS edges of the +2 and +4 outputs synchronized.

Select (SEL): LOW selects the ECL input source (DE/ \overline{DE}). HIGH selects the TTL input source (DT).

The H644 also contains circuitry to force a stable state of the ECL input differential pair, should both sides be left open. In this case, the DE side of the input is pulled LOW, and \overline{DE} goes HIGH.

Pinout: 20-Lead PLCC (Top View)

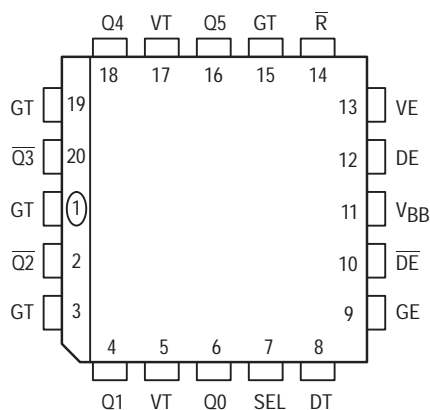

MECL 10H is a trademark of Motorola, Inc.

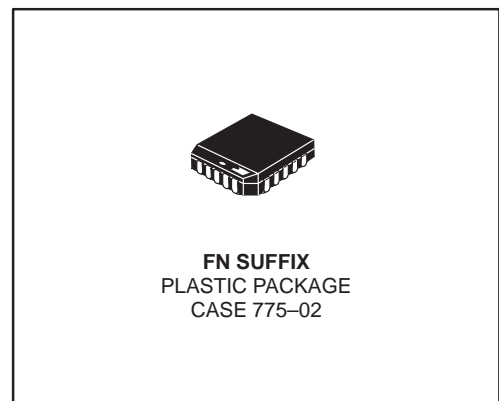
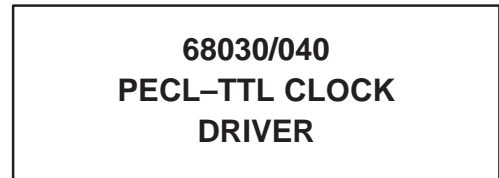
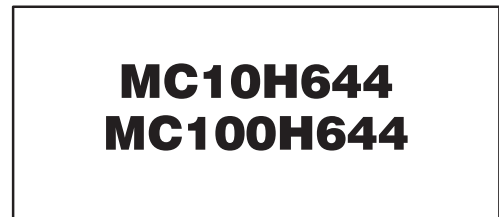

MC10H644 MC100H644

PIN NAMES

PIN	FUNCTION
GT	TTL Ground (0V)
VT	TTL V _{CC} (+5.0V)
VE	ECL V _{CC} (+5.0V)
GE	ECL Ground (0V)
DE, \overline{DE}	ECL Signal Input (positive ECL)
V _{BB}	V _{BB} Reference Output
DT	TTL Signal Input
Q _n , $\overline{Q_n}$	Signal Outputs (TTL)
SEL	Input Select (TTL)
R	Reset (TTL)

LOGIC DIAGRAM

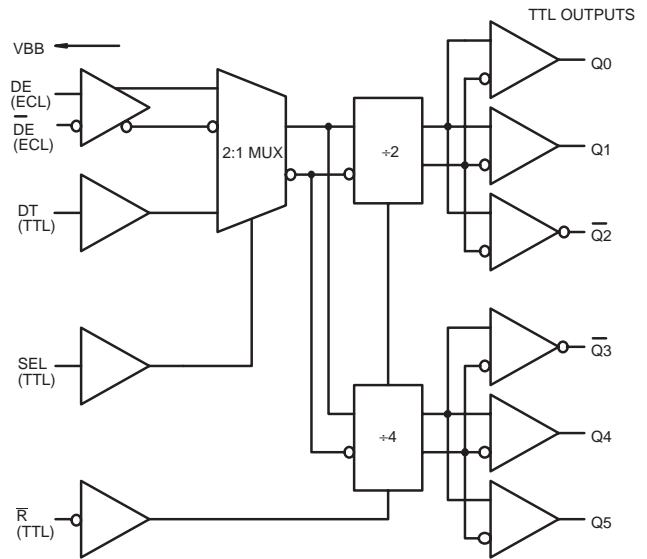

AC CHARACTERISTICS (VT = VE = 5.0 V ±5%)

Symbol	Characteristic		0°C		25°C		85°C		Unit	Condition
			Min	Max	Min	Max	Min	Max		
t _{PLH}	Propagation Delay ECL D to Output	All Outputs	5.8	6.8	5.7	6.7	6.1	7.1	ns	CL = 50pF
t _{PLH}	Propagation Delay TTL D to Output		5.7	6.7	5.7	6.7	6.0	7.0		
t _{skwd} *	Within-Device Skew	Q0, 1, 4, 5	-	0.5	-	0.5	-	0.5	ns	CL = 50pF
t _{skwd} *	Within-Device Skew	$\overline{Q_2}$, $\overline{Q_3}$	-	0.5	-	0.5	-	0.5		
t _{skwd} *	Within-Device Skew	All Outputs	-	1.5	-	1.5	-	1.5	ns	CL = 50pF
t _{skp-p} *	Part-to-Part Skew	Q0, 1, 4, 5	-	1.0	-	1.0	-	1.0		
t _{PD}	Propagation Delay R to Output	All Outputs	4.3	7.3	4.3	7.3	4.5	7.5	ns	CL = 50pF
t _R t _F	Output Rise/Fall Time 0.8V - 2.0V	All Outputs	-	1.6	-	1.6	-	1.6		
f _{max}	Maximum Input Frequency		135	-	135	-	135	-	MHz	CL = 50pF
TW	Minimum Pulse Width Reset		1.5	-	1.5	-	1.5	-		
t _{rr}	Reset Recovery Time		1.25	-	1.25	-	1.25	-	ns	CL = 50pf Relative 1.5V
T _{PW}	Pulse Width Out High or Low @ f _{in} = 100 MHz and CL = 50 pf	Q0, 1	9.5	10.5	9.5	10.5	9.5	10.5		
TS	Setup Time SEL to DE, DT		2.0	-	2.0	-	2.0	-	ns	
TH	Hold Time SEL to DE, DT		2.0	-	2.0	-	2.0	-		

* Skews are specified for Identical Edges

DC CHARACTERISTICS ($V_T = V_E = 5.0\text{ V} \pm 5\%$)

Symbol	Characteristic		0°C		25°C		85°C		Unit	Condition
			Min	Max	Min	Max	Min	Max		
I_{EE}	Power Supply Current	ECL		65		65		65	mA	VE Pin
I_{CC}		TTL		85		85		85	mA	Total all V_T pins

TTL DC CHARACTERISTICS ($V_T = V_E = 5.0\text{ V} \pm 5\%$)

Symbol	Characteristic	0°C		25°C		85°C		Unit	Condition
		Min	Max	Min	Max	Min	Max		
V_{IH} V_{IL}	Input HIGH Voltage Input LOW Voltage	2.0	0.8	2.0	0.8	2.0	0.8	V	
I_{IH}	Input HIGH Current		20 100		20 100		20 100	μA	$V_{IN} = 2.7\text{ V}$ $V_{IN} = 7.0\text{ V}$
I_{IL}	Input LOW Current		-0.6		-0.6		-0.6	mA	$V_{IN} = 0.5\text{ V}$
V_{OH}	Output HIGH Voltage	2.5 2.0		2.5 2.0		2.5 2.0		V	$I_{OH} = -3.0\text{ mA}$ $I_{OH} = -24\text{ mA}$
V_{OL}	Output LOW Voltage		0.5		0.5		0.5	V	$I_{OL} = 24\text{ mA}$
V_{IK}	Input Clamp Voltage		-1.2		-1.2		-1.2	V	$I_{IN} = -18\text{ mA}$
I_{OS}	Output Short Circuit Current	-100	-225	-100	-225	-100	-225	mA	$V_{OUT} = 0\text{ V}$

10H PECL DC CHARACTERISTICS ($V_T = V_E = 5.0\text{ V} \pm 5\%$)

Symbol	Characteristic	0°C		25°C		85°C		Unit	Condition
		Min	Max	Min	Max	Min	Max		
I_{IH} I_{IL}	Input HIGH Current Input LOW Current	0.5	225	0.5	175	0.5	175	μA	
V_{IH}^* V_{IL}^*	Input HIGH Voltage Input LOW Voltage	3.83 3.05	4.16 3.52	3.87 3.05	4.19 3.52	3.94 3.05	4.28 3.55	V	$V_E = 5.0\text{ V}$
V_{BB}^*	Output Reference Voltage	3.62	3.73	3.65	3.75	3.69	3.81	V	$V_E = 5.0\text{ V}$

100H PECL DC CHARACTERISTICS ($V_T = V_E = 5.0\text{ V} \pm 5\%$)

Symbol	Characteristic	0°C		25°C		85°C		Unit	Condition
		Min	Max	Min	Max	Min	Max		
I_{IH} I_{IL}	Input HIGH Current Input LOW Current	0.5	225	0.5	175	0.5	175	μA	
V_{IH}^* V_{IL}^*	Input HIGH Voltage Input LOW Voltage	3.835 3.19	4.12 3.525	3.835 3.19	4.12 3.525	3.835 3.19	4.12 3.525	V	$V_E = 5.0\text{ V}$
V_{BB}^*	Output Reference Voltage	3.62	3.74	3.62	3.74	3.62	3.74	V	$V_E = 5.0\text{ V}$

* NOTE: PECL levels are referenced to V_{CC} and will vary 1:1 with the power supply. The values shown are for $V_{CC} = 5.0\text{ V}$. Only corresponds to ECL Clock Inputs.

OUTLINE DIMENSIONS

FN SUFFIX
 PLASTIC PLCC PACKAGE
 CASE 776-02
 ISSUE D

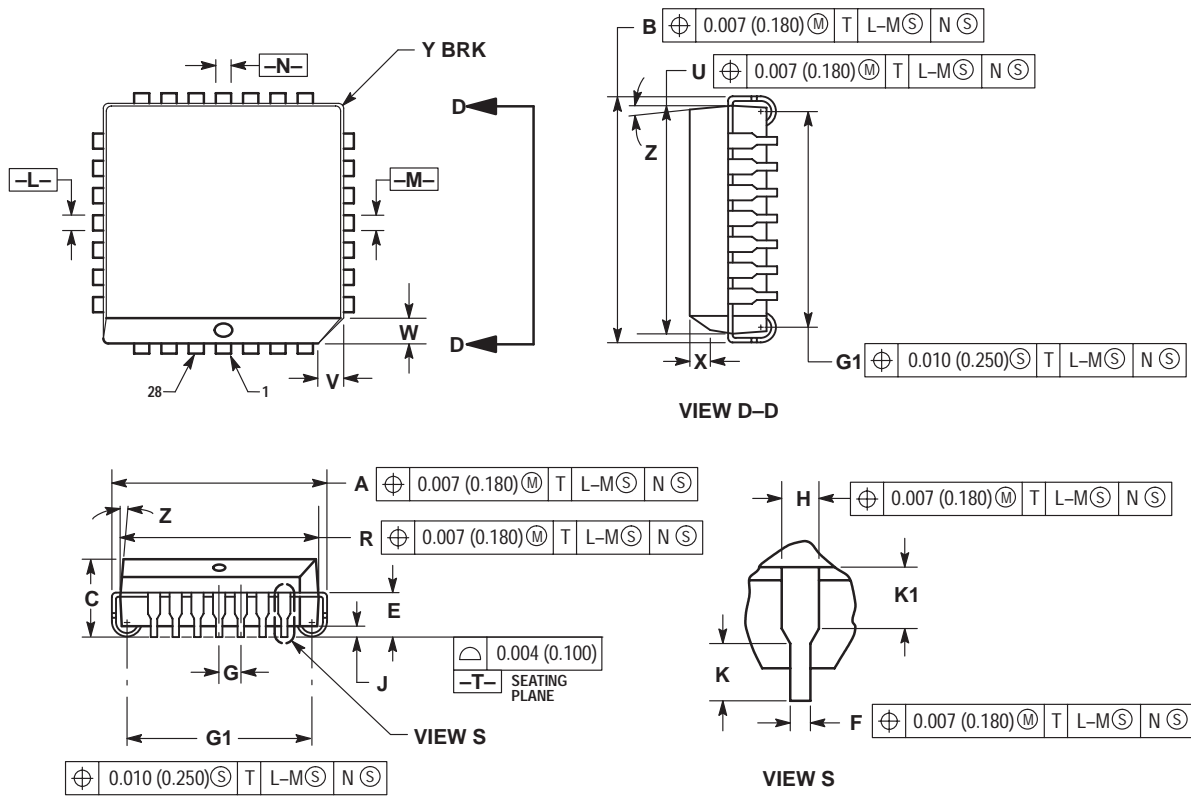

- NOTES:
- DATUMS -L-, -M-, AND -N- DETERMINED WHERE TOP OF LEAD SHOULDER EXITS PLASTIC BODY AT MOLD PARTING LINE.
 - DIMENSION G1, TRUE POSITION TO BE MEASURED AT DATUM -T-, SEATING PLANE.
 - DIMENSIONS R AND U DO NOT INCLUDE MOLD FLASH. ALLOWABLE MOLD FLASH IS 0.010 (0.250) PER SIDE.
 - DIMENSIONING AND TOLERANCING PER ANSI Y14.5M, 1982.
 - CONTROLLING DIMENSION: INCH.
 - THE PACKAGE TOP MAY BE SMALLER THAN THE PACKAGE BOTTOM BY UP TO 0.012 (0.300). DIMENSIONS R AND U ARE DETERMINED AT THE OUTERMOST EXTREMES OF THE PLASTIC BODY EXCLUSIVE OF MOLD FLASH, TIE BAR BURRS, GATE BURRS AND INTERLEAD FLASH, BUT INCLUDING ANY MISMATCH BETWEEN THE TOP AND BOTTOM OF THE PLASTIC BODY.
 - DIMENSION H DOES NOT INCLUDE DAMBAR PROTRUSION OR INTRUSION. THE DAMBAR PROTRUSION(S) SHALL NOT CAUSE THE H DIMENSION TO BE GREATER THAN 0.037 (0.940). THE DAMBAR INTRUSION(S) SHALL NOT CAUSE THE H DIMENSION TO BE SMALLER THAN 0.025 (0.635).

DIM	INCHES		MILLIMETERS	
	MIN	MAX	MIN	MAX
A	0.485	0.495	12.32	12.57
B	0.485	0.495	12.32	12.57
C	0.165	0.180	4.20	4.57
E	0.090	0.110	2.29	2.79
F	0.013	0.019	0.33	0.48
G	0.050 BSC		1.27 BSC	
H	0.026	0.032	0.66	0.81
J	0.020	---	0.51	---
K	0.025	---	0.64	---
R	0.450	0.456	11.43	11.58
U	0.450	0.456	11.43	11.58
V	0.042	0.048	1.07	1.21
W	0.042	0.048	1.07	1.21
X	0.042	0.056	1.07	1.42
Y	---	0.020	---	0.50
Z	2°		10°	
G1	0.410	0.430	10.42	10.92
K1	0.040	---	1.02	---

Motorola reserves the right to make changes without further notice to any products herein. Motorola makes no warranty, representation or guarantee regarding the suitability of its products for any particular purpose, nor does Motorola assume any liability arising out of the application or use of any product or circuit, and specifically disclaims any and all liability, including without limitation consequential or incidental damages. "Typical" parameters which may be provided in Motorola data sheets and/or specifications can and do vary in different applications and actual performance may vary over time. All operating parameters, including "Typicals" must be validated for each customer application by customer's technical experts. Motorola does not convey any license under its patent rights nor the rights of others. Motorola products are not designed, intended, or authorized for use as components in systems intended for surgical implant into the body, or other applications intended to support or sustain life, or for any other application in which the failure of the Motorola product could create a situation where personal injury or death may occur. Should Buyer purchase or use Motorola products for any such unintended or unauthorized application, Buyer shall indemnify and hold Motorola and its officers, employees, subsidiaries, affiliates, and distributors harmless against all claims, costs, damages, and expenses, and reasonable attorney fees arising out of, directly or indirectly, any claim of personal injury or death associated with such unintended or unauthorized use, even if such claim alleges that Motorola was negligent regarding the design or manufacture of the part. Motorola and  are registered trademarks of Motorola, Inc. Motorola, Inc. is an Equal Opportunity/Affirmative Action Employer.

How to reach us:

USA/EUROPE/Locations Not Listed: Motorola Literature Distribution;
P.O. Box 20912; Phoenix, Arizona 85036. 1-800-441-2447 or 602-303-5454

MFAX: RMFAX0@email.sps.mot.com – TOUCHTONE 602-244-6609

INTERNET: <http://Design-NET.com>

JAPAN: Nippon Motorola Ltd.; Tatsumi-SPD-JLDC, 6F Seibu-Butsuryu-Center,
3-14-2 Tatsumi Koto-Ku, Tokyo 135, Japan. 03-81-3521-8315

ASIA/PACIFIC: Motorola Semiconductors H.K. Ltd.; 8B Tai Ping Industrial Park,
51 Ting Kok Road, Tai Po, N.T., Hong Kong. 852-26629298



MC10H644/D

