

# MC14538B

## Dual Precision Retriggerable/Resettable Monostable Multivibrator

The MC14538B is a dual, retriggerable, resettable monostable multivibrator. It may be triggered from either edge of an input pulse, and produces an accurate output pulse over a wide range of widths, the duration and accuracy of which are determined by the external timing components,  $C_X$  and  $R_X$ .

Output Pulse Width =  $(C_X)(R_X)$  where:

$R_X$  is in  $k\Omega$

$C_X$  is in  $\mu F$

- Unlimited Rise and Fall Time Allowed on the A Trigger Input
- Pulse Width Range = 10  $\mu s$  to 10 s
- Latched Trigger Inputs
- Separate Latched Reset Inputs
- 3.0 Vdc to 18 Vdc Operational Limits
- Triggerable from Positive (A Input) or Negative-Going Edge (B-Input)
- Capable of Driving Two Low-power TTL Loads or One Low-power Schottky TTL Load Over the Rated Temperature Range
- Pin-for-pin Compatible with MC14528B and CD4528B (CD4098)
- Use the MC54/74HC4538A for Pulse Widths Less Than 10  $\mu s$  with Supplies Up to 6 V.

### MAXIMUM RATINGS (Voltages Referenced to $V_{SS}$ ) (Note 2.)

Symbol	Parameter	Value	Unit
$V_{DD}$	DC Supply Voltage Range	-0.5 to +18.0	V
$V_{in}, V_{out}$	Input or Output Voltage Range (DC or Transient)	-0.5 to $V_{DD} + 0.5$	V
$I_{in}, I_{out}$	Input or Output Current (DC or Transient) per Pin	$\pm 10$	mA
$P_D$	Power Dissipation, per Package (Note 3.)	500	mW
$T_A$	Operating Temperature Range	-55 to +125	$^{\circ}C$
$T_{stg}$	Storage Temperature Range	-65 to +150	$^{\circ}C$
$T_L$	Lead Temperature (8-Second Soldering)	260	$^{\circ}C$

2. Maximum Ratings are those values beyond which damage to the device may occur.

3. Temperature Derating:

Plastic "P and D/DW" Packages: - 7.0 mW/ $^{\circ}C$  From 65 $^{\circ}C$  To 125 $^{\circ}C$

This device contains protection circuitry to guard against damage due to high static voltages or electric fields. However, precautions must be taken to avoid applications of any voltage higher than maximum rated voltages to this high-impedance circuit. For proper operation,  $V_{in}$  and  $V_{out}$  should be constrained to the range  $V_{SS} \leq (V_{in} \text{ or } V_{out}) \leq V_{DD}$ .

Unused inputs must always be tied to an appropriate logic voltage level (e.g., either  $V_{SS}$  or  $V_{DD}$ ). Unused outputs must be left open.



ON Semiconductor

<http://onsemi.com>

**MARKING DIAGRAMS**

**PDIP-16**  
P SUFFIX  
CASE 648

**SOIC-16**  
D SUFFIX  
CASE 751B

**TSSOP-16**  
DT SUFFIX  
CASE 948F

**SOIC-16**  
DW SUFFIX  
CASE 751G

**SOEIAJ-16**  
F SUFFIX  
CASE 966

A = Assembly Location  
WL or L = Wafer Lot  
YY or Y = Year  
WW or W = Work Week

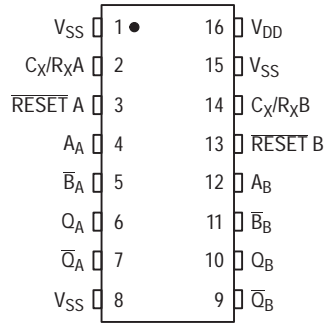
### ORDERING INFORMATION

Device	Package	Shipping
MC14538BCP	PDIP-16	2000/Box
MC14538BD	SOIC-16	48/Rail
MC14538BDR2	SOIC-16	2500/Tape & Reel
MC14538BDT	TSSOP-16	96/Rail
MC14538BDTR2	TSSOP-16	2500/Tape & Reel
MC14538BDW	SOIC-16	47/Rail
MC14538BDWR2	SOIC-16	1000/Tape & Reel
MC14538BF	SOEIAJ-16	See Note 1.
MC14538BFEL	SOEIAJ-16	See Note 1.

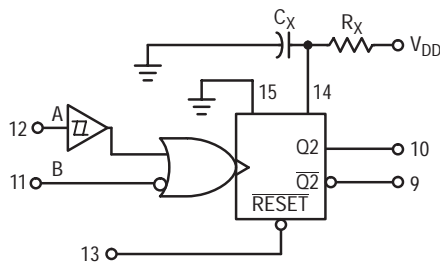
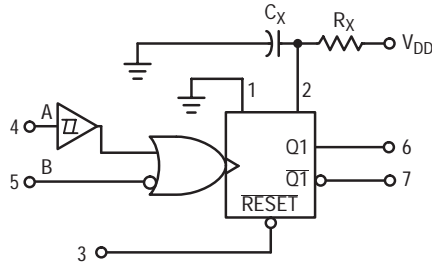
1. For ordering information on the EIAJ version of the SOIC packages, please contact your local ON Semiconductor representative.

# MC14538B

## PIN ASSIGNMENT



## BLOCK DIAGRAM

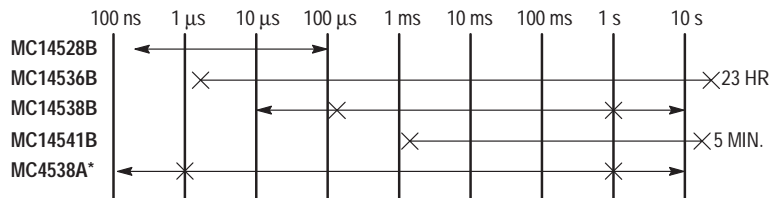


R<sub>X</sub> AND C<sub>X</sub> ARE EXTERNAL COMPONENTS.

V<sub>DD</sub> = PIN 16

V<sub>SS</sub> = PIN 8, PIN 1, PIN 15

## ONE-SHOT SELECTION GUIDE



\*LIMITED OPERATING VOLTAGE (2 - 6 V)

TOTAL OUTPUT PULSE WIDTH RANGE ←-----→

RECOMMENDED PULSE WIDTH RANGE ×-----×

# MC14538B

## ELECTRICAL CHARACTERISTICS (Voltages Referenced to V<sub>SS</sub>)

Characteristic	Symbol	V <sub>DD</sub> Vdc	- 55 °C		25 °C			125 °C		Unit	
			Min	Max	Min	Typ <sup>(4.)</sup>	Max	Min	Max		
Output Voltage V <sub>in</sub> = V <sub>DD</sub> or 0	"0" Level V <sub>OL</sub>	5.0	—	0.05	—	0	0.05	—	0.05	Vdc	
		10	—	0.05	—	0	0.05	—	0.05		
		15	—	0.05	—	0	0.05	—	0.05		
	"1" Level V <sub>in</sub> = 0 or V <sub>DD</sub>	V <sub>OH</sub>	5.0	4.95	—	4.95	5.0	—	4.95		—
			10	9.95	—	9.95	10	—	9.95		—
			15	14.95	—	14.95	15	—	14.95		—
Input Voltage (V <sub>O</sub> = 4.5 or 0.5 Vdc) (V <sub>O</sub> = 9.0 or 1.0 Vdc) (V <sub>O</sub> = 13.5 or 1.5 Vdc)	"0" Level V <sub>IL</sub>	5.0	—	1.5	—	2.25	1.5	—	1.5	Vdc	
		10	—	3.0	—	4.50	3.0	—	3.0		
		15	—	4.0	—	6.75	4.0	—	4.0		
	"1" Level (V <sub>O</sub> = 0.5 or 4.5 Vdc) (V <sub>O</sub> = 1.0 or 9.0 Vdc) (V <sub>O</sub> = 1.5 or 13.5 Vdc)	V <sub>IH</sub>	5.0	3.5	—	3.5	2.75	—	3.5		—
			10	7.0	—	7.0	5.50	—	7.0		—
			15	11	—	11	8.25	—	11		—
Output Drive Current (V <sub>OH</sub> = 2.5 Vdc) (V <sub>OH</sub> = 4.6 Vdc) (V <sub>OH</sub> = 9.5 Vdc) (V <sub>OH</sub> = 13.5 Vdc)	Source I <sub>OH</sub>	5.0	- 3.0	—	- 2.4	- 4.2	—	- 1.7	—	mAdc	
		5.0	- 0.64	—	- 0.51	- 0.88	—	- 0.36	—		
		10	- 1.6	—	- 1.3	- 2.25	—	- 0.9	—		
		15	- 4.2	—	- 3.4	- 8.8	—	- 2.4	—		
	Sink I <sub>OL</sub>	5.0	0.64	—	0.51	0.88	—	0.36	—		
		10	1.6	—	1.3	2.25	—	0.9	—		
15	4.2	—	3.4	8.8	—	2.4	—	—			
Input Current, Pin 2 or 14	I <sub>in</sub>	15	—	±0.05	—	±0.00001	±0.05	—	±0.5	μAdc	
Input Current, Other Inputs	I <sub>in</sub>	15	—	±0.1	—	±0.00001	±0.1	—	±1.0	μAdc	
Input Capacitance, Pin 2 or 14	C <sub>in</sub>	—	—	—	—	25	—	—	—	pF	
Input Capacitance, Other Inputs (V <sub>in</sub> = 0)	C <sub>in</sub>	—	—	—	—	5.0	7.5	—	—	pF	
Quiescent Current (Per Package) Q = Low, Q̄ = High	I <sub>DD</sub>	5.0	—	5.0	—	0.005	5.0	—	150	μAdc	
		10	—	10	—	0.010	10	—	300		
		15	—	20	—	0.015	20	—	600		
Quiescent Current, Active State (Both) (Per Package) Q = High, Q̄ = Low	I <sub>DD</sub>	5.0	—	2.0	—	0.04	0.20	—	2.0	mAdc	
		10	—	2.0	—	0.08	0.45	—	2.0		
		15	—	2.0	—	0.13	0.70	—	2.0		
Total Supply Current at an external load capacitance (C <sub>L</sub> ) and at external timing network (R <sub>X</sub> , C <sub>X</sub> ) <sup>(5.)</sup>	I <sub>T</sub>	5.0 10	$I_T = (3.5 \times 10^{-2}) R_X C_X f + 4 C_X f + 1 \times 10^{-5} C_L f$ $I_T = (8.0 \times 10^{-2}) R_X C_X f + 9 C_X f + 2 \times 10^{-5} C_L f$ $I_T = (1.25 \times 10^{-1}) R_X C_X f + 12 C_X f + 3 \times 10^{-5} C_L f$ where: I <sub>T</sub> in μA (one monostable switching only), C <sub>X</sub> in μF, C <sub>L</sub> in pF, R <sub>X</sub> in k ohms, and f in Hz is the input frequency.							μAdc	

4. Data labelled "Typ" is not to be used for design purposes but is intended as an indication of the IC's potential performance.

5. The formulas given are for the typical characteristics only at 25°C.

## MC14538B

### SWITCHING CHARACTERISTICS (6.) ( $C_L = 50 \text{ pF}$ , $T_A = 25^\circ\text{C}$ )

Characteristic	Symbol	$V_{DD}$ Vdc	All Types			Unit
			Min	Typ (7.)	Max	
Output Rise Time $t_{TLH} = (1.35 \text{ ns/pF}) C_L + 33 \text{ ns}$ $t_{TLH} = (0.60 \text{ ns/pF}) C_L + 20 \text{ ns}$ $t_{TLH} = (0.40 \text{ ns/pF}) C_L + 20 \text{ ns}$	$t_{TLH}$	5.0 10 15	— — —	100 50 40	200 100 80	ns
Output Fall Time $t_{THL} = (1.35 \text{ ns/pF}) C_L + 33 \text{ ns}$ $t_{THL} = (0.60 \text{ ns/pF}) C_L + 20 \text{ ns}$ $t_{THL} = (0.40 \text{ ns/pF}) C_L + 20 \text{ ns}$	$t_{THL}$	5.0 10 15	— — —	100 50 40	200 100 80	ns
Propagation Delay Time A or B to Q or $\bar{Q}$ $t_{PLH}, t_{PHL} = (0.90 \text{ ns/pF}) C_L + 255 \text{ ns}$ $t_{PLH}, t_{PHL} = (0.36 \text{ ns/pF}) C_L + 132 \text{ ns}$ $t_{PLH}, t_{PHL} = (0.26 \text{ ns/pF}) C_L + 87 \text{ ns}$  Reset to Q or $\bar{Q}$ $t_{PLH}, t_{PHL} = (0.90 \text{ ns/pF}) C_L + 205 \text{ ns}$ $t_{PLH}, t_{PHL} = (0.36 \text{ ns/pF}) C_L + 107 \text{ ns}$ $t_{PLH}, t_{PHL} = (0.26 \text{ ns/pF}) C_L + 82 \text{ ns}$	$t_{PLH},$ $t_{PHL}$	5.0 10 15  5.0 10 15	— — —  — — —	300 150 100  250 125 95	600 300 220  500 250 190	ns   ns
Input Rise and Fall Times Reset  B Input  A Input	$t_r, t_f$	5 10 15  5 10 15  5 10 15	— — —  — — —  — — —	— — —  300 1.2 0.4  No Limit	15 5 4  1.0 0.1 0.05  —	$\mu\text{s}$  ms  —
Input Pulse Width A, B, or Reset	$t_{WH},$ $t_{WL}$	5.0 10 15	170 90 80	85 45 40	— — —	ns
Retrigger Time	$t_{rr}$	5.0 10 15	0 0 0	— — —	— — —	ns
Output Pulse Width — Q or $\bar{Q}$ Refer to Figures 8 and 9 $C_X = 0.002 \mu\text{F}, R_X = 100 \text{ k}\Omega$  $C_X = 0.1 \mu\text{F}, R_X = 100 \text{ k}\Omega$  $C_X = 10 \mu\text{F}, R_X = 100 \text{ k}\Omega$	T	5.0 10 15  5.0 10 15  5.0 10 15	198 200 202  9.3 9.4 9.5  0.91 0.92 0.93	210 212 214  9.86 10 10.14  0.965 0.98 0.99	230 232 234  10.5 10.6 10.7  1.03 1.04 1.06	$\mu\text{s}$  ms  s
Pulse Width Match between circuits in the same package. $C_X = 0.1 \mu\text{F}, R_X = 100 \text{ k}\Omega$	100 [( $T_1 - T_2$ )/ $T_1$ ]	5.0 10 15	— — —	$\pm 1.0$ $\pm 1.0$ $\pm 1.0$	$\pm 5.0$ $\pm 5.0$ $\pm 5.0$	%

6. The formulas given are for the typical characteristics only at 25°C.

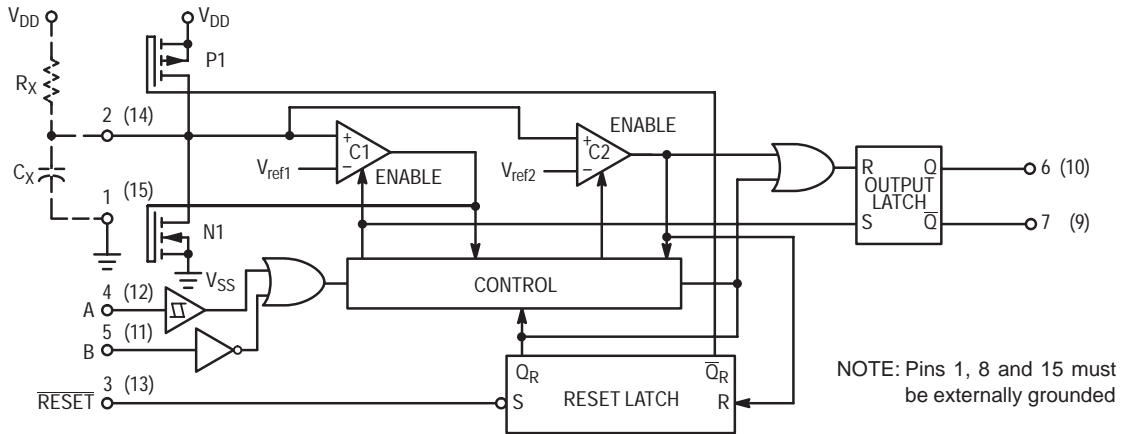
7. Data labelled "Typ" is not to be used for design purposes but is intended as an indication of the IC's potential performance.

# MC14538B

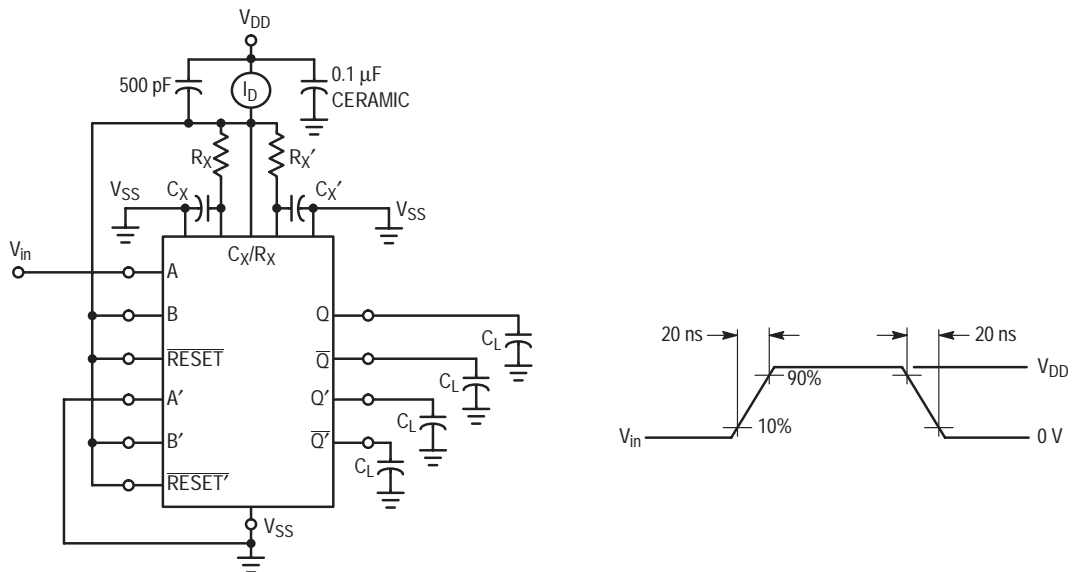
## OPERATING CONDITIONS

External Timing Resistance	$R_X$	—	5.0	—	(8.)	$k\Omega$
External Timing Capacitance	$C_X$	—	0	—	No Limit (9.)	$\mu F$

8. The maximum usable resistance  $R_X$  is a function of the leakage of the capacitor  $C_X$ , leakage of the MC14538B, and leakage due to board layout and surface resistance. Susceptibility to externally induced noise signals may occur for  $R_X > 1 M\Omega$ .
9. If  $C_X > 15 \mu F$ , use discharge protection diode per Fig. 11.

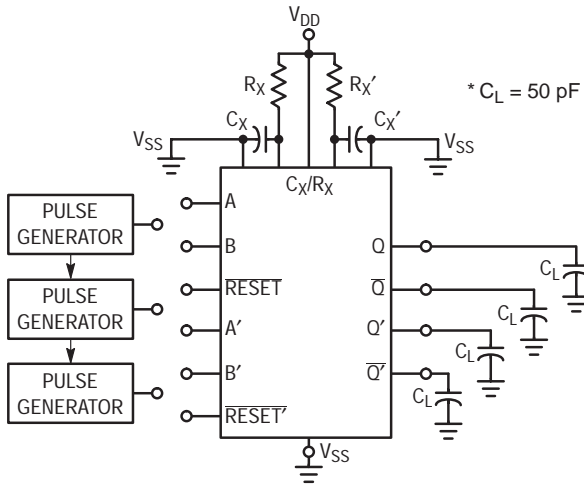


**Figure 1. Logic Diagram  
(1/2 of Device Shown)**



**Figure 2. Power Dissipation Test Circuit and Waveforms**

# MC14538B



## INPUT CONNECTIONS

Characteristics	Reset	A	B
$t_{PLH}$ , $t_{PHL}$ , $t_{TLH}$ , $t_{THL}$ , $T$ , $t_{WH}$ , $t_{WL}$	$V_{DD}$	PG1	$V_{DD}$
$t_{PLH}$ , $t_{PHL}$ , $t_{TLH}$ , $t_{THL}$ , $T$ , $t_{WH}$ , $t_{WL}$	$V_{DD}$	$V_{SS}$	PG2
$t_{PLH(R)}$ , $t_{PHL(R)}$ , $t_{WH}$ , $t_{WL}$	PG3	PG1	PG2

\* Includes capacitance of probes, wiring, and fixture parasitic.

NOTE: Switching test waveforms for PG1, PG2, PG3 are shown in Figure 4.

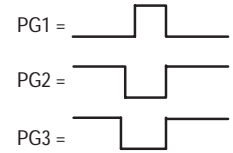


Figure 3. Switching Test Circuit

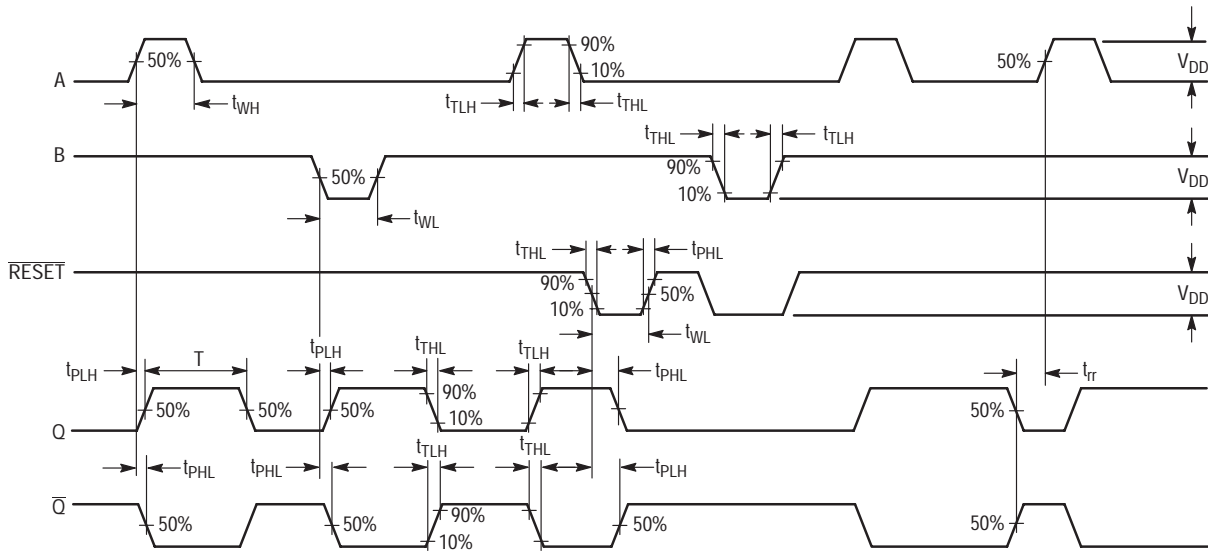


Figure 4. Switching Test Waveforms

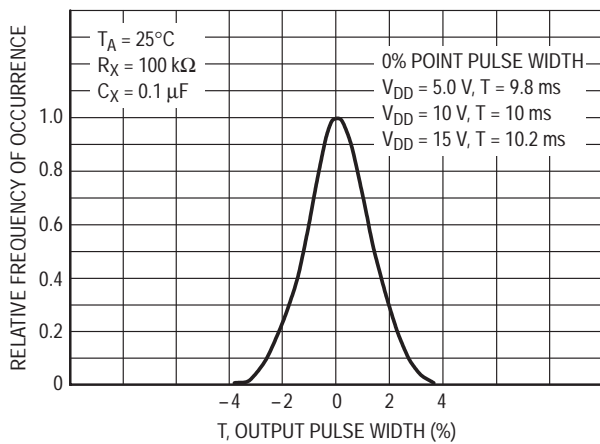


Figure 5. Typical Normalized Distribution of Units for Output Pulse Width

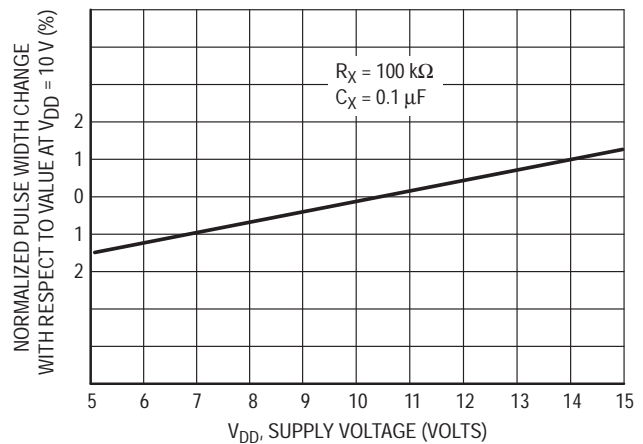
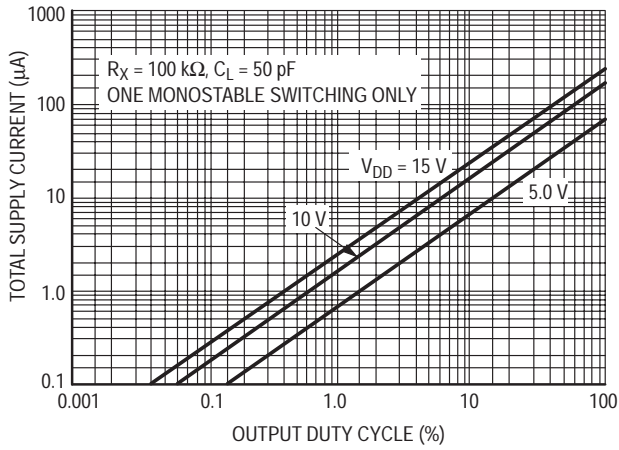


Figure 6. Typical Pulse Width Variation as a Function of Supply Voltage  $V_{DD}$

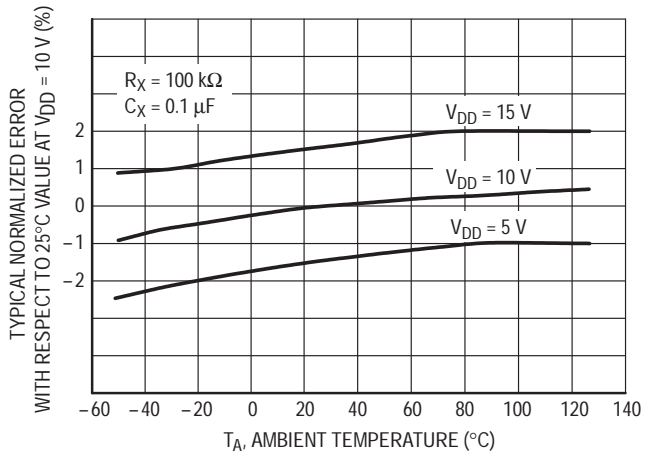
# MC14538B



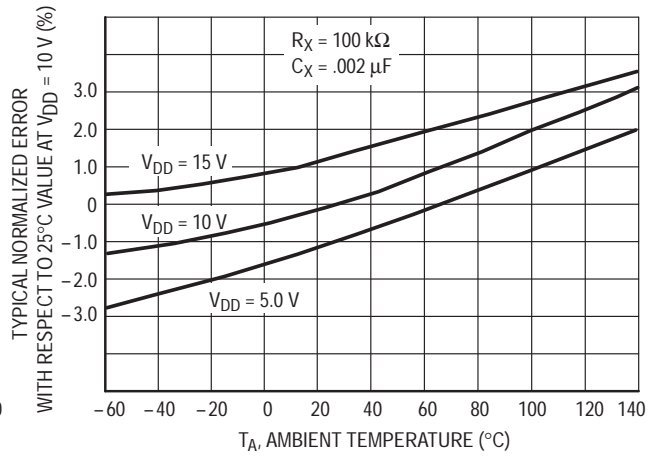
**Figure 7. Typical Total Supply Current versus Output Duty Cycle**

## FUNCTION TABLE

Inputs			Outputs	
Reset	A	B	Q	Q̄
H		H		
H	L			
H		L	Not Triggered	Not Triggered
H	H		Not Triggered	Not Triggered
H	L, H,	H	Not Triggered	Not Triggered
H	L	L, H,	Not Triggered	Not Triggered
L	X	X	L	H
	X	X	Not Triggered	Not Triggered



**Figure 8. Typical Error of Pulse Width Equation versus Temperature**



**Figure 9. Typical Error of Pulse Width Equation versus Temperature**

# MC14538B

## THEORY OF OPERATION

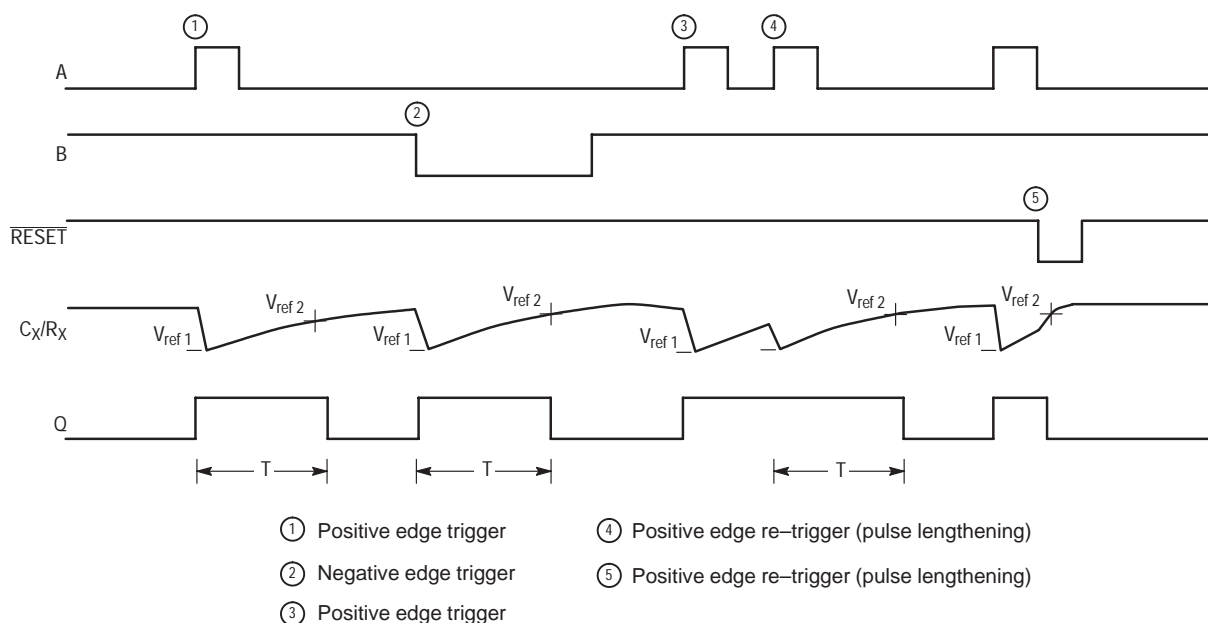


Figure 10. Timing Operation

### TRIGGER OPERATION

The block diagram of the MC14538B is shown in Figure 1, with circuit operation following.

As shown in Figure 1 and 10, before an input trigger occurs, the monostable is in the quiescent state with the Q output low, and the timing capacitor C<sub>X</sub> completely charged to V<sub>DD</sub>. When the trigger input A goes from V<sub>SS</sub> to V<sub>DD</sub> (while inputs B and  $\overline{\text{Reset}}$  are held to V<sub>DD</sub>) a valid trigger is recognized, which turns on comparator C1 and N-channel transistor N1. At the same time the output latch is set. With transistor N1 on, the capacitor C<sub>X</sub> rapidly discharges toward V<sub>SS</sub> until V<sub>ref1</sub> is reached. At this point the output of comparator C1 changes state and transistor N1 turns off. Comparator C1 then turns off while at the same time comparator C2 turns on. With transistor N1 off, the capacitor C<sub>X</sub> begins to charge through the timing resistor, R<sub>X</sub>, toward V<sub>DD</sub>. When the voltage across C<sub>X</sub> equals V<sub>ref2</sub>, comparator C2 changes state, causing the output latch to reset (Q goes low) while at the same time disabling comparator C2. This ends at the timing cycle with the monostable in the quiescent state, waiting for the next trigger.

In the quiescent state, C<sub>X</sub> is fully charged to V<sub>DD</sub> causing the current through resistor R<sub>X</sub> to be zero. Both comparators are "off" with total device current due only to reverse junction leakages. An added feature of the MC14538B is that the output latch is set via the input trigger without regard to the capacitor voltage. Thus, propagation delay from trigger to Q is independent of the value of C<sub>X</sub>, R<sub>X</sub>, or the duty cycle of the input waveform.

### RETRIGGER OPERATION

The MC14538B is retriggered if a valid trigger occurs followed by another valid trigger before the Q output has returned to the quiescent (zero) state. Any retrigger, after the timing node voltage at pin 2 or 14 has begun to rise from V<sub>ref1</sub>, but has not yet reached V<sub>ref2</sub>, will cause an increase in output pulse width T. When a valid retrigger is initiated, the voltage at C<sub>X</sub>/R<sub>X</sub> will again drop to V<sub>ref1</sub> before progressing along the RC charging curve toward V<sub>DD</sub>. The Q output will remain high until time T, after the last valid retrigger.

### RESET OPERATION

The MC14538B may be reset during the generation of the output pulse. In the reset mode of operation, an input pulse on  $\overline{\text{Reset}}$  sets the reset latch and causes the capacitor to be fast charged to V<sub>DD</sub> by turning on transistor P1. When the voltage on the capacitor reaches V<sub>ref2</sub>, the reset latch will clear, and will then be ready to accept another pulse. If the  $\overline{\text{Reset}}$  input is held low, any trigger inputs that occur will be inhibited and the Q and  $\overline{Q}$  outputs of the output latch will not change. Since the Q output is reset when an input low level is detected on the  $\overline{\text{Reset}}$  input, the output pulse T can be made significantly shorter than the minimum pulse width specification.



# MC14538B

## POWER-DOWN CONSIDERATIONS

Large capacitance values can cause problems due to the large amount of energy stored. When a system containing the MC14538B is powered down, the capacitor voltage may discharge from  $V_{DD}$  through the standard protection diodes at pin 2 or 14. Current through the protection diodes should be limited to 10 mA and therefore the discharge time of the  $V_{DD}$  supply must not be faster than  $(V_{DD}) \cdot (C) / (10 \text{ mA})$ . For example, if  $V_{DD} = 10 \text{ V}$  and  $C_X = 10 \mu\text{F}$ , the  $V_{DD}$  supply should discharge no faster than  $(10 \text{ V}) \times (10 \mu\text{F}) / (10 \text{ mA}) = 10 \text{ ms}$ . This is normally not a problem since power supplies are heavily filtered and cannot discharge at this rate.

When a more rapid decrease of  $V_{DD}$  to zero volts occurs, the MC14538B can sustain damage. To avoid this possibility use an external clamping diode,  $D_X$ , connected as shown in Fig. 11.

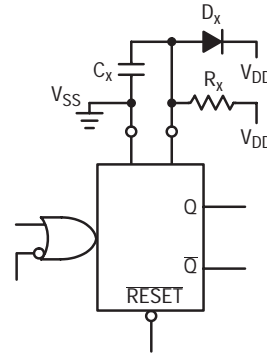


Figure 11. Use of a Diode to Limit Power Down Current Surge

## TYPICAL APPLICATIONS

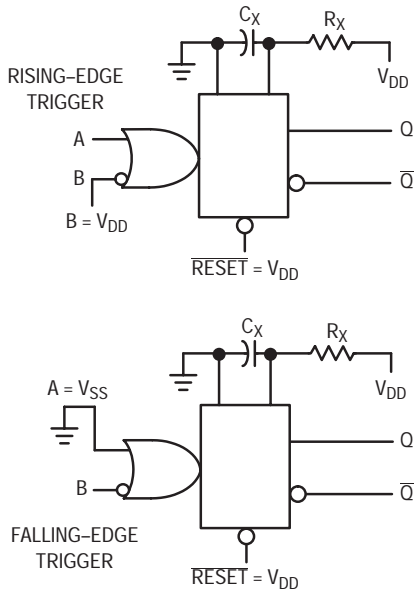


Figure 12. Retriggerable Monostables Circuitry

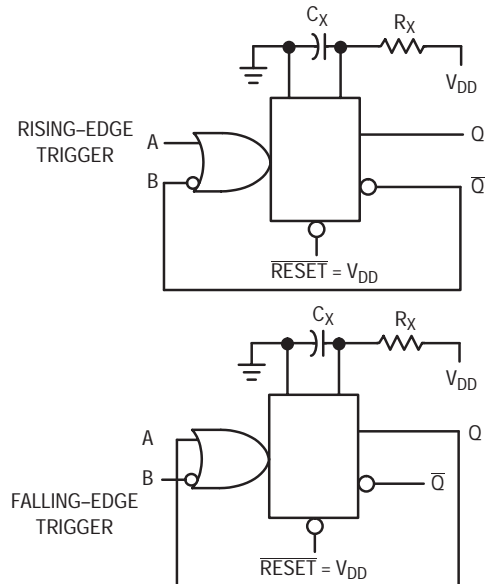


Figure 13. Non-Retriggerable Monostables Circuitry

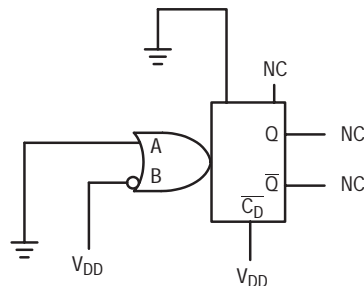
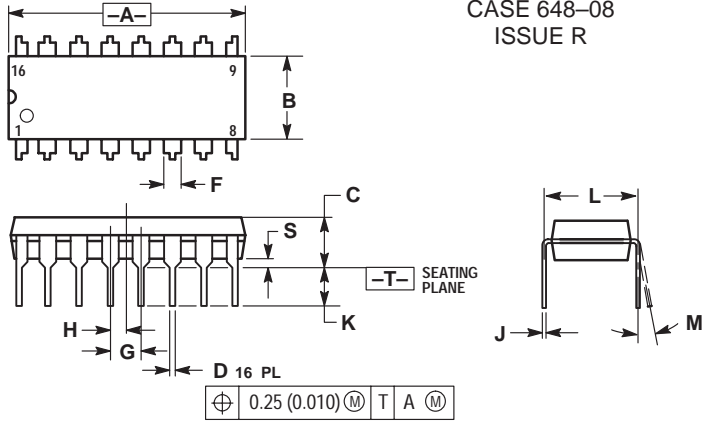


Figure 14. Connection of Unused Sections

# MC14538B

## PACKAGE DIMENSIONS

### PDIP-16 P SUFFIX PLASTIC DIP PACKAGE CASE 648-08 ISSUE R

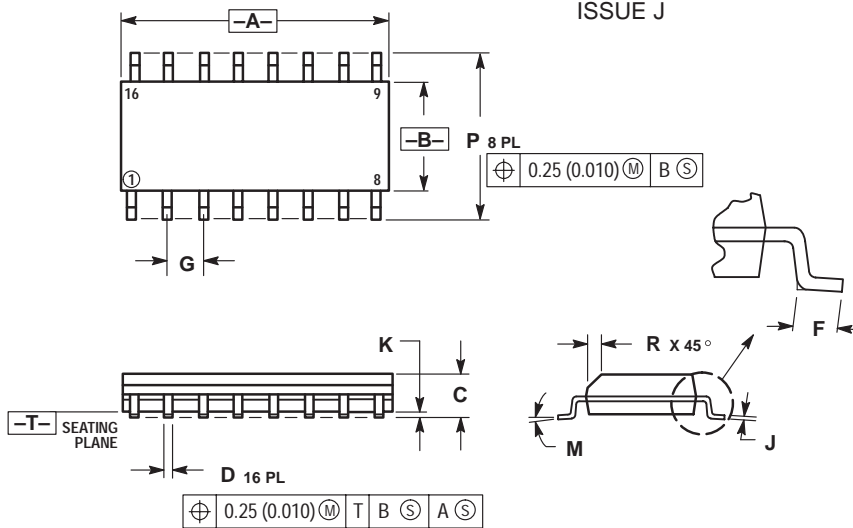


NOTES:

1. DIMENSIONING AND TOLERANCING PER ANSI Y14.5M, 1982.
2. CONTROLLING DIMENSION: INCH.
3. DIMENSION L TO CENTER OF LEADS WHEN FORMED PARALLEL.
4. DIMENSION B DOES NOT INCLUDE MOLD FLASH.
5. ROUNDED CORNERS OPTIONAL.

DIM	INCHES		MILLIMETERS	
	MIN	MAX	MIN	MAX
A	0.740	0.770	18.80	19.55
B	0.250	0.270	6.35	6.85
C	0.145	0.175	3.69	4.44
D	0.015	0.021	0.39	0.53
F	0.040	0.70	1.02	1.77
G	0.100 BSC		2.54 BSC	
H	0.050 BSC		1.27 BSC	
J	0.008	0.015	0.21	0.38
K	0.110	0.130	2.80	3.30
L	0.295	0.305	7.50	7.74
M	0°	10°	0°	10°
S	0.020	0.040	0.51	1.01

### SOIC-16 D SUFFIX PLASTIC SOIC PACKAGE CASE 751B-05 ISSUE J



NOTES:

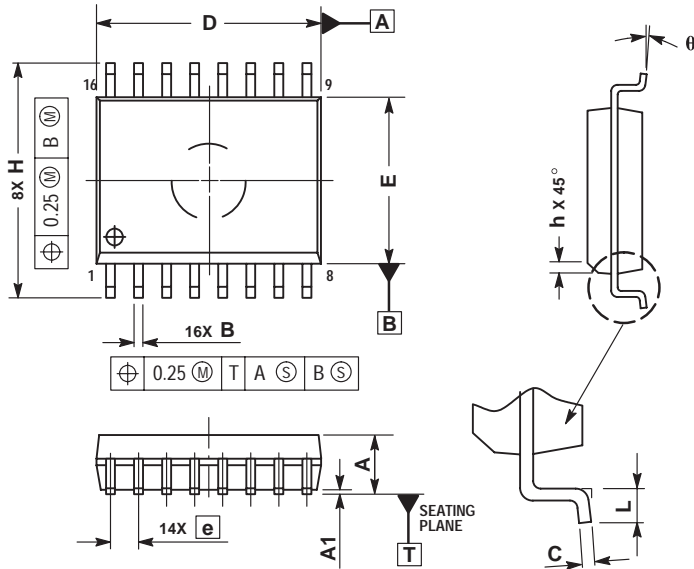
1. DIMENSIONING AND TOLERANCING PER ANSI Y14.5M, 1982.
2. CONTROLLING DIMENSION: MILLIMETER.
3. DIMENSIONS A AND B DO NOT INCLUDE MOLD PROTRUSION.
4. MAXIMUM MOLD PROTRUSION 0.15 (0.006) PER SIDE.
5. DIMENSION D DOES NOT INCLUDE DAMBAR PROTRUSION. ALLOWABLE DAMBAR PROTRUSION SHALL BE 0.127 (0.005) TOTAL IN EXCESS OF THE D DIMENSION AT MAXIMUM MATERIAL CONDITION.

DIM	MILLIMETERS		INCHES	
	MIN	MAX	MIN	MAX
A	9.80	10.00	0.386	0.393
B	3.80	4.00	0.150	0.157
C	1.35	1.75	0.054	0.068
D	0.35	0.49	0.014	0.019
F	0.40	1.25	0.016	0.049
G	1.27 BSC		0.050 BSC	
J	0.19	0.25	0.008	0.009
K	0.10	0.25	0.004	0.009
M	0°	7°	0°	7°
P	5.80	6.20	0.229	0.244
R	0.25	0.50	0.010	0.019

# MC14538B

## PACKAGE DIMENSIONS

**SOIC-16**  
**DW SUFFIX**  
 PLASTIC SOIC PACKAGE  
 CASE 751G-03  
 ISSUE B

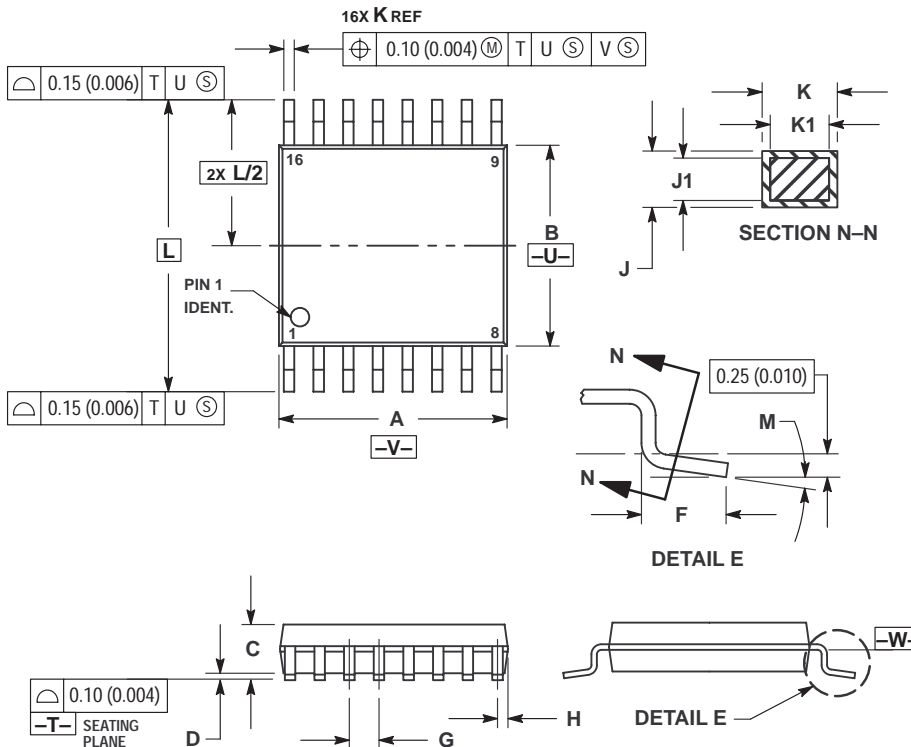


**NOTES:**

1. DIMENSIONS ARE IN MILLIMETERS.
2. INTERPRET DIMENSIONS AND TOLERANCES PER ASME Y14.5M, 1994.
3. DIMENSIONS D AND E DO NOT INCLUDE MOLD PROTRUSION.
4. MAXIMUM MOLD PROTRUSION 0.15 PER SIDE.
5. DIMENSION B DOES NOT INCLUDE DAMBAR PROTRUSION. ALLOWABLE DAMBAR PROTRUSION SHALL BE 0.13 TOTAL IN EXCESS OF THE B DIMENSION AT MAXIMUM MATERIAL CONDITION.

DIM	MILLIMETERS	
	MIN	MAX
A	2.35	2.65
A1	0.10	0.25
B	0.35	0.49
C	0.23	0.32
D	10.15	10.45
E	7.40	7.60
e	1.27 BSC	
H	10.05	10.55
h	0.25	0.75
L	0.50	0.90
θ	0°	7°

**TSSOP-16**  
**DT SUFFIX**  
 PLASTIC TSSOP PACKAGE  
 CASE 948F-01  
 ISSUE O



**NOTES:**

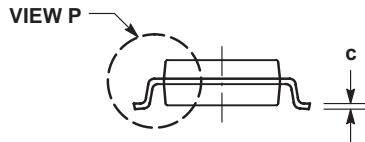
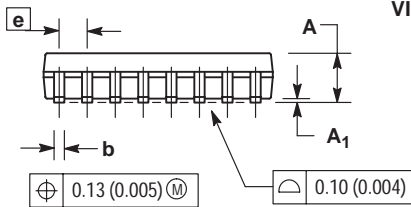
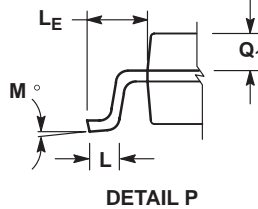
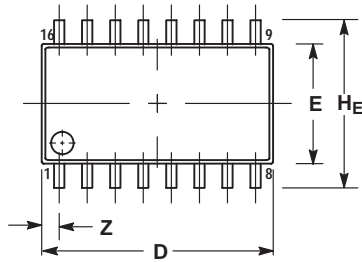
1. DIMENSIONING AND TOLERANCING PER ANSI Y14.5M, 1982.
2. CONTROLLING DIMENSION: MILLIMETER.
3. DIMENSION A DOES NOT INCLUDE MOLD FLASH, PROTRUSIONS OR GATE BURRS. MOLD FLASH OR GATE BURRS SHALL NOT EXCEED 0.15 (0.006) PER SIDE.
4. DIMENSION B DOES NOT INCLUDE INTERLEAD FLASH OR PROTRUSION. INTERLEAD FLASH OR PROTRUSION SHALL NOT EXCEED 0.25 (0.010) PER SIDE.
5. DIMENSION K DOES NOT INCLUDE DAMBAR PROTRUSION. ALLOWABLE DAMBAR PROTRUSION SHALL BE 0.08 (0.003) TOTAL IN EXCESS OF THE K DIMENSION AT MAXIMUM MATERIAL CONDITION.
6. TERMINAL NUMBERS ARE SHOWN FOR REFERENCE ONLY.
7. DIMENSION A AND B ARE TO BE DETERMINED AT DATUM PLANE -W-.

DIM	MILLIMETERS		INCHES	
	MIN	MAX	MIN	MAX
A	4.90	5.10	0.193	0.200
B	4.30	4.50	0.169	0.177
C	---	1.20	---	0.047
D	0.05	0.15	0.002	0.006
F	0.50	0.75	0.020	0.030
G	0.65 BSC		0.026 BSC	
H	0.18	0.28	0.007	0.011
J	0.09	0.20	0.004	0.008
J1	0.09	0.16	0.004	0.006
K	0.19	0.30	0.007	0.012
K1	0.19	0.25	0.007	0.010
L	6.40 BSC		0.252 BSC	
M	0°	8°	0°	8°

# MC14538B

## PACKAGE DIMENSIONS


SOEIAJ-16  
F SUFFIX  
PLASTIC EIAJ SOIC PACKAGE  
CASE 966-01  
ISSUE O



NOTES:

1. DIMENSIONING AND TOLERANCING PER ANSI Y14.5M, 1982.
2. CONTROLLING DIMENSION: MILLIMETER.
3. DIMENSIONS D AND E DO NOT INCLUDE MOLD FLASH OR PROTRUSIONS AND ARE MEASURED AT THE PARTING LINE. MOLD FLASH OR PROTRUSIONS SHALL NOT EXCEED 0.15 (0.006) PER SIDE.
4. TERMINAL NUMBERS ARE SHOWN FOR REFERENCE ONLY.
5. THE LEAD WIDTH DIMENSION (b) DOES NOT INCLUDE DAMBAR PROTRUSION. ALLOWABLE DAMBAR PROTRUSION SHALL BE 0.08 (0.003) TOTAL IN EXCESS OF THE LEAD WIDTH DIMENSION AT MAXIMUM MATERIAL CONDITION. DAMBAR CANNOT BE LOCATED ON THE LOWER RADIUS OR THE FOOT. MINIMUM SPACE BETWEEN PROTRUSIONS AND ADJACENT LEAD TO BE 0.46 (0.018).

DIM	MILLIMETERS		INCHES	
	MIN	MAX	MIN	MAX
A	----	2.05	----	0.081
A <sub>1</sub>	0.05	0.20	0.002	0.008
b	0.35	0.50	0.014	0.020
c	0.18	0.27	0.007	0.011
D	9.90	10.50	0.390	0.413
E	5.10	5.45	0.201	0.215
e	1.27 BSC		0.050 BSC	
H <sub>E</sub>	7.40	8.20	0.291	0.323
L	0.50	0.85	0.020	0.033
L <sub>F</sub>	1.10	1.50	0.043	0.059
M	0°	10°	0°	10°
Q <sub>1</sub>	0.70	0.90	0.028	0.035
Z	----	0.78	----	0.031

ON Semiconductor and  are trademarks of Semiconductor Components Industries, LLC (SCILLC). SCILLC reserves the right to make changes without further notice to any products herein. SCILLC makes no warranty, representation or guarantee regarding the suitability of its products for any particular purpose, nor does SCILLC assume any liability arising out of the application or use of any product or circuit, and specifically disclaims any and all liability, including without limitation special, consequential or incidental damages. "Typical" parameters which may be provided in SCILLC data sheets and/or specifications can and do vary in different applications and actual performance may vary over time. All operating parameters, including "Typicals" must be validated for each customer application by customer's technical experts. SCILLC does not convey any license under its patent rights nor the rights of others. SCILLC products are not designed, intended, or authorized for use as components in systems intended for surgical implant into the body, or other applications intended to support or sustain life, or for any other application in which the failure of the SCILLC product could create a situation where personal injury or death may occur. Should Buyer purchase or use SCILLC products for any such unintended or unauthorized application, Buyer shall indemnify and hold SCILLC and its officers, employees, subsidiaries, affiliates, and distributors harmless against all claims, costs, damages, and expenses, and reasonable attorney fees arising out of, directly or indirectly, any claim of personal injury or death associated with such unintended or unauthorized use, even if such claim alleges that SCILLC was negligent regarding the design or manufacture of the part. SCILLC is an Equal Opportunity/Affirmative Action Employer.

### PUBLICATION ORDERING INFORMATION

**NORTH AMERICA Literature Fulfillment:**

Literature Distribution Center for ON Semiconductor  
P.O. Box 5163, Denver, Colorado 80217 USA  
Phone: 303-675-2175 or 800-344-3860 Toll Free USA/Canada  
Fax: 303-675-2176 or 800-344-3867 Toll Free USA/Canada  
Email: ONlit@hibbertco.com  
Fax Response Line: 303-675-2167 or 800-344-3810 Toll Free USA/Canada

**N. American Technical Support:** 800-282-9855 Toll Free USA/Canada

**EUROPE:** LDC for ON Semiconductor – European Support

**German Phone:** (+1) 303-308-7140 (M-F 1:00pm to 5:00pm Munich Time)  
Email: ONlit\_german@hibbertco.com  
**French Phone:** (+1) 303-308-7141 (M-F 1:00pm to 5:00pm Toulouse Time)  
Email: ONlit\_french@hibbertco.com  
**English Phone:** (+1) 303-308-7142 (M-F 12:00pm to 5:00pm UK Time)  
Email: ONlit@hibbertco.com

**EUROPEAN TOLL-FREE ACCESS\*: 00-800-4422-3781**

\*Available from Germany, France, Italy, England, Ireland

**CENTRAL/SOUTH AMERICA:**

**Spanish Phone:** 303-308-7143 (Mon-Fri 8:00am to 5:00pm MST)  
Email: ONlit-spanish@hibbertco.com

**ASIA/PACIFIC:** LDC for ON Semiconductor – Asia Support

**Phone:** 303-675-2121 (Tue-Fri 9:00am to 1:00pm, Hong Kong Time)  
Toll Free from Hong Kong & Singapore:  
**001-800-4422-3781**  
Email: ONlit-asia@hibbertco.com

**JAPAN:** ON Semiconductor, Japan Customer Focus Center

4-32-1 Nishi-Gotanda, Shinagawa-ku, Tokyo, Japan 141-8549  
**Phone:** 81-3-5740-2745  
Email: r14525@onsemi.com

**ON Semiconductor Website:** <http://onsemi.com>

For additional information, please contact your local Sales Representative.