

Hallogic® Hall Effect Sensors

Types OHN3019U, OHS3019U

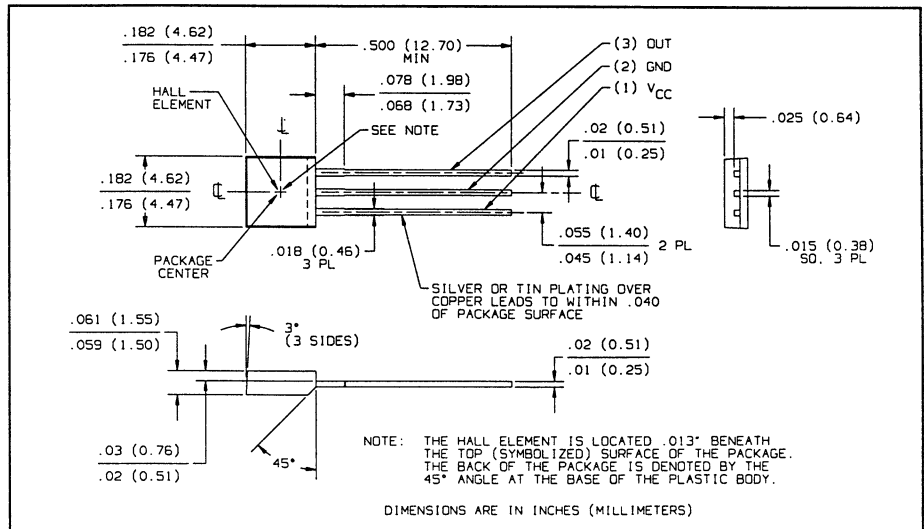
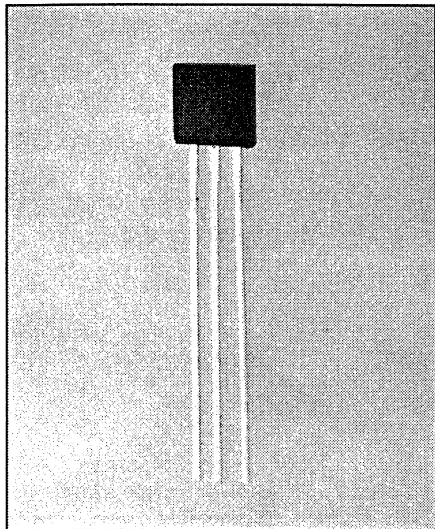

Features

- Operates over a broad range of supply voltages
- Excellent temperature stability to operate in harsh environments
- Drive capability up to 7 TTL loads
- Hall element, linear amplifier, and Schmitt trigger on a single Hallogic® silicon chip

Description

The OHN3019U and OHS3019U each contain a monolithic integrated circuit which incorporates a Hall element, a linear amplifier, and Schmitt trigger on a single silicon chip. Included on-chip is a bandgap voltage regulator to allow operation with a wide range of supply voltages. The device features logic level output and provides up to 21 mA of sink current. This allows direct driving of more than 7 TTL loads or any standard logic family using power supplies ranging from 4.5 to 24 volts. Output amplitude is constant at switching frequencies from DC to over 200 kHz.

Stability of the magnetic operate and release points is excellent over this entire temperature range.

Package size has been kept to minimum, providing an advantage in applications where space is limited.

Absolute Maximum Ratings ($T_A = 25^\circ\text{C}$ unless otherwise noted)

Supply Voltage, V_{CC}	25 V
Storage Temperature Range, T_S	-65°C to $+150^\circ\text{C}$
Operating Temperature Range, T_A OHN3019U.....	-20°C to $+85^\circ\text{C}$
OHS3019U.....	-40°C to $+125^\circ\text{C}$
Lead Soldering Temperature [1/8 inch (3.2 mm) from case for 5 sec. with soldering iron].....	260°C (1)
Output ON Current, I_{SINK}	25 mA
Output OFF Voltage, V_{OUT}	25 V
Magnetic Flux Density, B.....	Unlimited

Note:

(1) Heat sink leads during hand soldering.

Functional Block Diagram

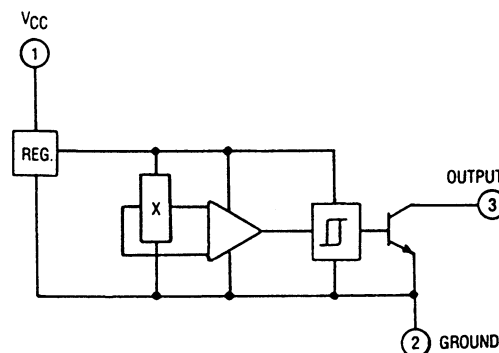

Types OHN3019U, OHS3019U

Electrical Characteristics ($V_{CC} = 4.5 \text{ V to } 24 \text{ VDC}$, $T_A = 25^\circ \text{ C}$ unless otherwise noted)

SYMBOL	PARAMETER	MIN	TYP	MAX	UNITS	TEST CONDITIONS
B _{OP}	Magnetic Operate Point ⁽²⁾		300	500	Gauss	
B _{RP}	Magnetic Release Point	125	235		Gauss	
B _H	Magnetic Hysteresis	50	65		Gauss	
I _{CC}	Supply Current		4	7	mA	$V_{CC} = 24 \text{ V}$, Output Off
V _{OL}	Output Saturation Voltage		100	400	mV	$V_{CC} = 4.5 \text{ V}$, $I_{OL} = 20 \text{ mA}$, $B \geq 500 \text{ Gauss}$
I _{OH}	Output Leakage Current		0.1	10.0	μA	$V_{CC} = 24 \text{ V}$, $V_{OUT} = 24 \text{ V}$, $B \leq 100 \text{ Gauss}$
t _r	Output Rise Time		0.21	1.00	μs	$R_L = 820 \Omega$, $C_L = 20 \text{ pF}$
t _f	Output Fall Time		0.25	1.00	μs	

(2) South pole facing symbolized surface.

Typical Performance Curves

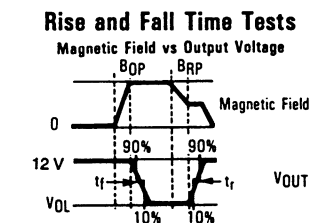
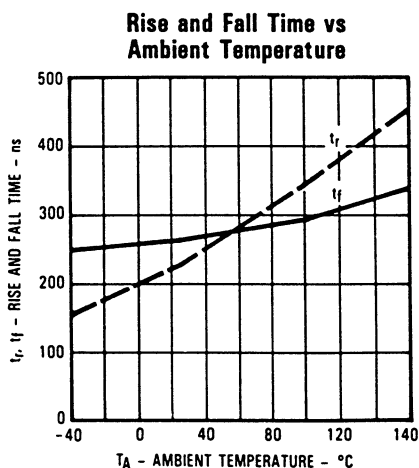
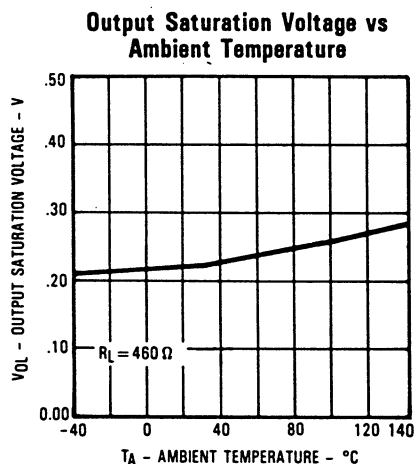
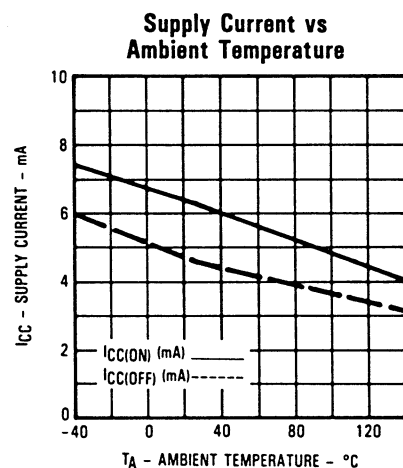
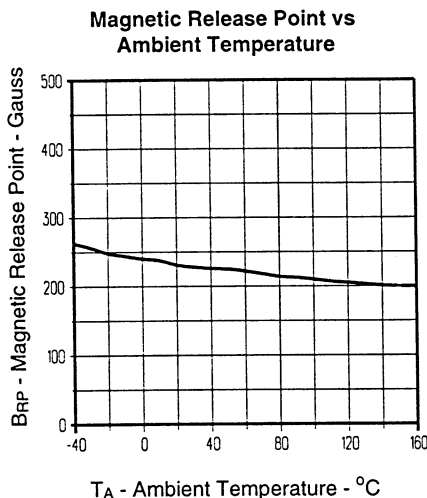
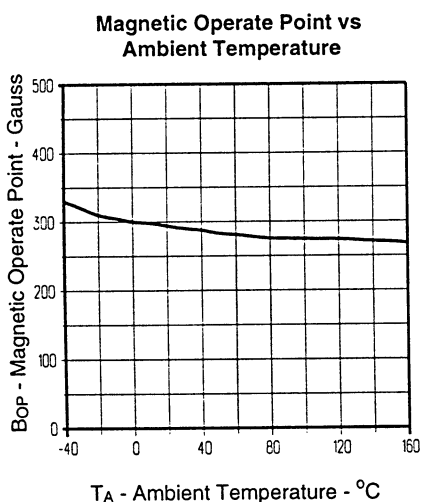

Rise and Fall Time Test Circuit

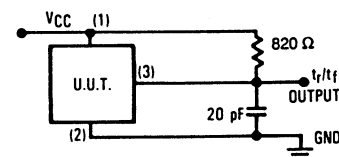

Optek reserves the right to make changes at any time in order to improve design and to supply the best product possible.

Optek Technology, Inc. 1215 W. Crosby Road Carrollton, Texas 75006 (972)323-2200 Fax (972)323-2396