

<div style="border: 1px solid black; border-radius: 10px; padding: 5px; display: inline-block;"> LCD Module Specification </div>		First Edition	Approved by	Production
		June 20, 2002	Checked by	Quality Assurance
		Final Revision	Checked by	Engineering
		*****	Drawn by	Engineering
Type No.	T - 5 1 4 4 0 G L 0 7 0 H U - F W - A C			

Table of Contents

1. Application	2
2. Mechanical Specification	2
3. Absolute Maximum Ratings.....	3
4. Environment Condition.....	3
5. Optical Characteristics	4
6. Electrical Characteristics	10
7. Product Standard.....	19
8. Reliability Test.....	22
9. Code System of Production Lot.....	24
10. Packing Specification	25
11. Product handling Cautions	26
12. Condition for Guarantee.....	27

Revision History

Rev.	Date	Page	Comment

1.Application

This specification applies to 7.0" color TFT-LCD module (T-51440GL070HU-FW-AC).
The applications of the panel are for automotive entertainment and car navigation.

2.Mechanical Specifications

- Screen Size : 7 inches (18cm) diagonal
- Display Mode : Normally White
- Driving Method : a-Si TFT active matrix format
Line Scan/non-interlace Reverse Horizontal Line
- Composition : TFT Cell, Driver IC, Timing controller IC, Backlight unit, Inverter
DC/DC Converter, and Video circuit
- Input Power Supply : +8V-16V(DC)
- Input Signal : Composite Video Signal (NTSC/PAL) or
Specific Analog RGB signal (NTSC/PAL) + Composite or Separate
Synchronized signal
- Output Signal : Horizontal/Vertical Synchronized signal (negative)
- Resolution : 480(W) x 234(H)
- Dot Resolution : 1440(W) x 234(H)
- Dot Pitch : 0.3210(W) x 0.3720(H) mm
- Pixel Configuration : RGB Stripe
- Active Area : 154.08(W) x 87.048(H) mm
- Backlight : Triple wavelength L-shaped Cold Cathode Fluorescent Lamp, Dimming
Ratio 1-100%
- Viewing Direction : 12 O'clock (Maximum Contrast)
- Surface Treatment : AGLR Coating (Low Reflectance)
- Outer Dimension : 164.9(W) x 101.9(H) x 23.1(D) mm
- Weight : TBD g max.
- Attached Drawing : Dimensional Outline UE-210547-00

3. Absolute Maximum Ratings

Item		Symbol	Conditions	Min.	Max.	Unit
Power Supply	Video Circuit	V_{PW}	$T_a=25 \pm 5?$ $V_{SS}=0V$	$V_{SS}-0.2$	16.0	V
	Backlight	V_{BL}		$V_{SS}-0.2$	16.0	V
Input Signal	Composite Video	VIDEO	$T_a=25 \pm 5?$ 750 $V_{PW}=V_{BL}=+12.0V$	-	1.5	V_{P-P}
	Analog RGB	R,G,B		-	1.5	V_{P-P}
	Synchronous Signals	VS _Y ,HS _Y		-	1.5	V_{P-P}
	Chroma Signal	CYSYNC		-	1.5	V_{P-P}
	Adjustment Signals	COLOR, BRT,CONT, TINT,DIM	$T_a=25 \pm 5?$ $V_{SS}=0V$ $V_{PW}=V_{BL}=+12.0V$	$V_{SS}-0.3$	$V_{DD}+0.3$	V
	Switching Signals	U/D,R/L, MOD1~ 3, N/P/R/CMP, YC/CMP		$V_{SS}-0.3$	$V_{DD}+0.3$	V
Storage Temperature		T_{stg}	-	-40	+85	?
Operating Temperature		T_{opr}	-	-30	+85	?

Note: Absolute maximum ratings should not exceed the limit anytime. If the product exceeds the limit, it may cause damage. Please be cautious to the changes in supply voltage, connection parts, surge of signals and ambient temperature.

4. Operating Conditions

Item		Conditions	Temperature Range	Remark
Operating Temperature Range	LCD Module w/Backlight	Ambient Temperature (Panel Surface)	-30- 85? (-30- 85?)	Note4-1,4-2
	LCD Panel	Surface Temperature	-30- 75?	
Storage Temperature Range	LCD Module w/Backlight	Surface Temperature	-40- 85?	Note4-3
	LCD Panel	Surface Temperature	-40- 85?	

Note4-1: Operating temperature range defines the operation only and the contrast, response time and other display optical characteristics are set at $T_a=+25?$.

Note4-2: Panel surface temperature indicates the temperature of the backlight panel surface on the five points from the four corners and the center. Also note that the panel temperature of backlight side is 10? (reference value) higher than the other side.

Note4-3: Backlight is not activated.

5. Optical Specifications

Item	Symbol	Conditions			Standard Value			Unit	Method of Measure	Remark
		?	f	C	Min.	Typ.	Max.			
(1) Brightness	B	0°	0°	/	-	(400)	-	Cd/m ²	(Fig.5-1)	Note5-1
(2) Contrast	CR	Optimum Viewing			60	150	-	-		
(3) White Chromaticity	X	0°	0°	/	0.265	0.305	0.345	-		
	Y	0°	0°	/	0.300	0.340	0.380	-		
(4) Brightness Uniformity	-	0°	0°	/	0.7	-	-	-	(Fig.5-2)	
(5) Vertical Viewing Angle	Up	? _U	-	0°	? 10	-	(60)	-	Degree	(Fig.5-3)
	Down	? _D	-	0°	? 10	-	(30)	-	Degree	
(6) Horizontal Viewing Angle	Left	F _L	0°	-	? 10	-	(60)	-	Degree	
	Right	f _R	0°	-	? 10	-	(60)	-	Degree	
(7) Response Time	Rise	t _r	0°	0°	/	-	TBD	TBD	ms	(Fig.5-4)
	Decay	t _d	0°	0°	/	-	TBD	TBD	Ms	

Note5-1: Under the condition of tube current 6.0mA

? Conditions for Measuring

? Environment: Dark room with no light or close to no light.

? Temperature: 25 ± 5 ?

? Humidity: 40 ~ 70 % RH

? After backlight has been lit more than 30 minutes, driving voltage is set for optimal contrast to measure center of display.

? Measure by the specified inverter or similar product.

? Optimal viewing angle (The angle with best contrast)

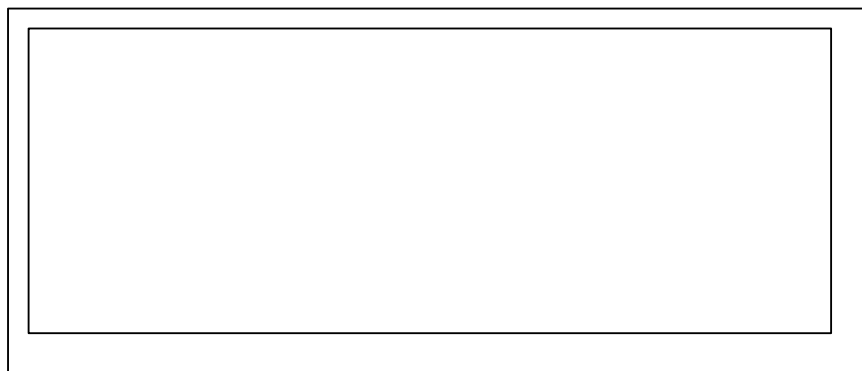
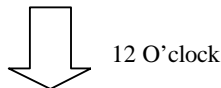

(Fig.5 - 1)

Preliminary

? Method of Brightness Measurement

(1) Measuring Device

TOPCON BM-7 ? Measuring Field : 1°

(2) Measuring Point

Center of Display ? = 0° ? $f = 0^\circ$

On condition ? : A vertical angle from measuring direction to perpendicular.

f : A horizontal angle from measuring direction to perpendicular.

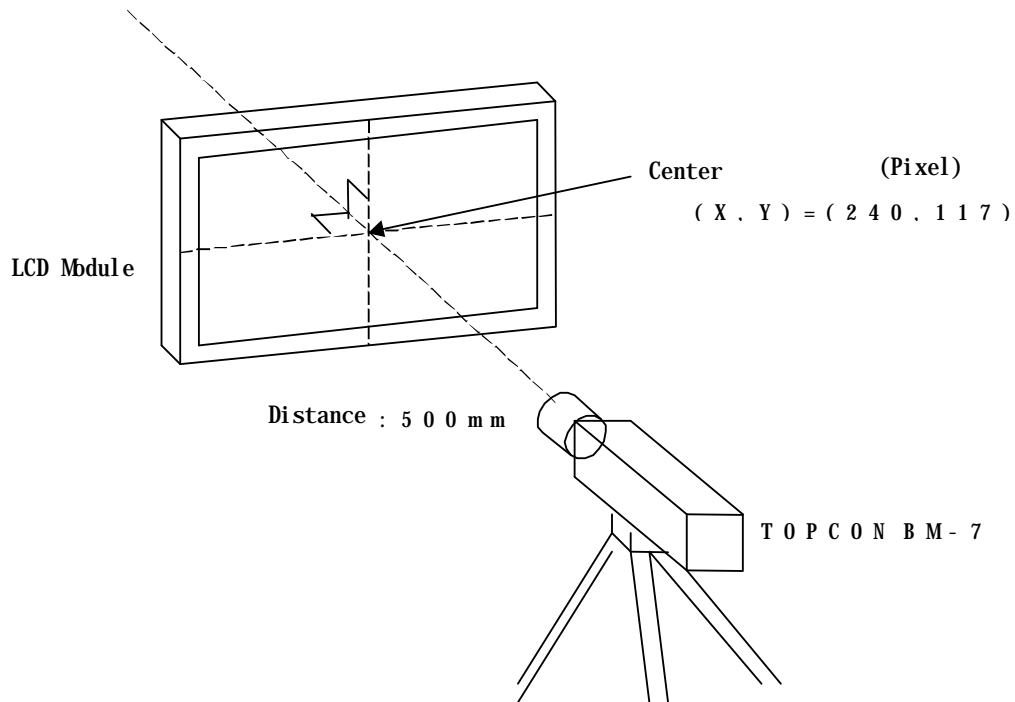

(3) Method of Measuring

Apply signal voltage (displayed in white) to maximize brightness and measure brightness B (cd/m^2).

The distance between BM-7's front lens to surface panel is 500mm.

Measured after backlight has been lit for more than 30 minutes.

? Method of Contrast Measurement

(1) Measuring Device

TOPCON BM-7 ? Measuring Field : 1°

(2) Measuring Point

Center of display: same as Method of Brightness Measurement

(3) Method of Measuring

- Set LCD module to ? = 0° ? $f = 0^\circ$.
- Change signal voltage to measure maximum brightness Y1 and minimum brightness Y2.
- Contrast is derived from $\text{CR} = \text{Y1}/\text{Y2}$.

(Fig.5 - 2)

? Definition of Brightness Uniformity

Definition is calculated from the four points (S0-S4) on the diagram below.

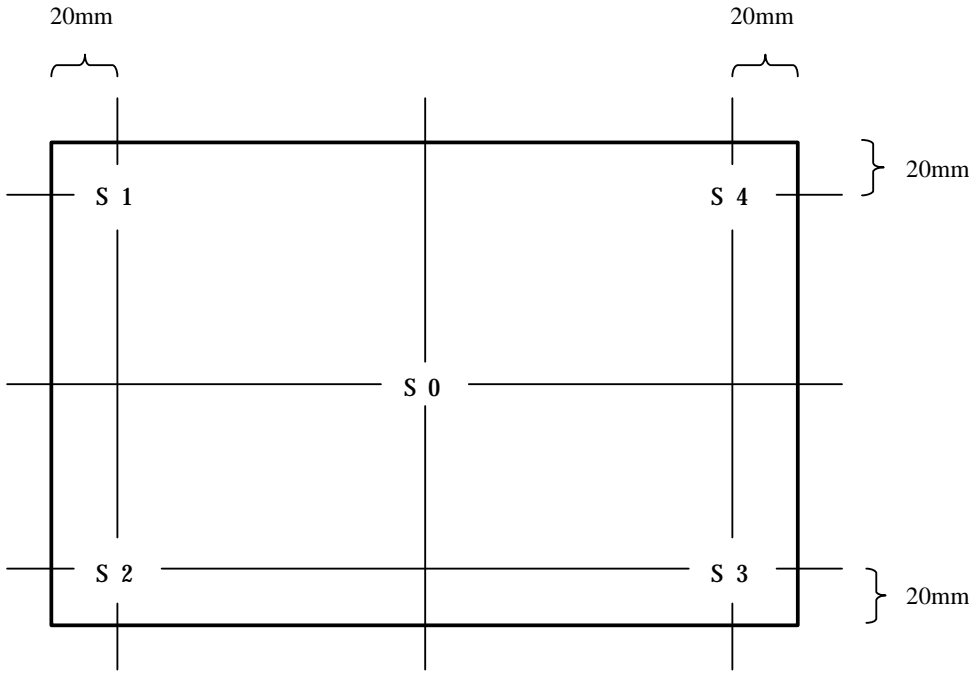

$$\text{Standard Value of Brightness Uniformity} = \frac{\text{Minimum Value of S1-S4}}{S0}$$

(Fig.5 - 3)

? Method of Viewing Angle Measurement

(1) Measuring Device

TOPCON BM-7 ? Measuring Field : 1 °

(2) Measuring Point

Center of display : Same as Method of Brightness Measurement

(3) Angle of Measuring

? : An angle vertical to perpendicular line from the viewing direction.

F : An angle horizontal to perpendicular from the viewing direction.

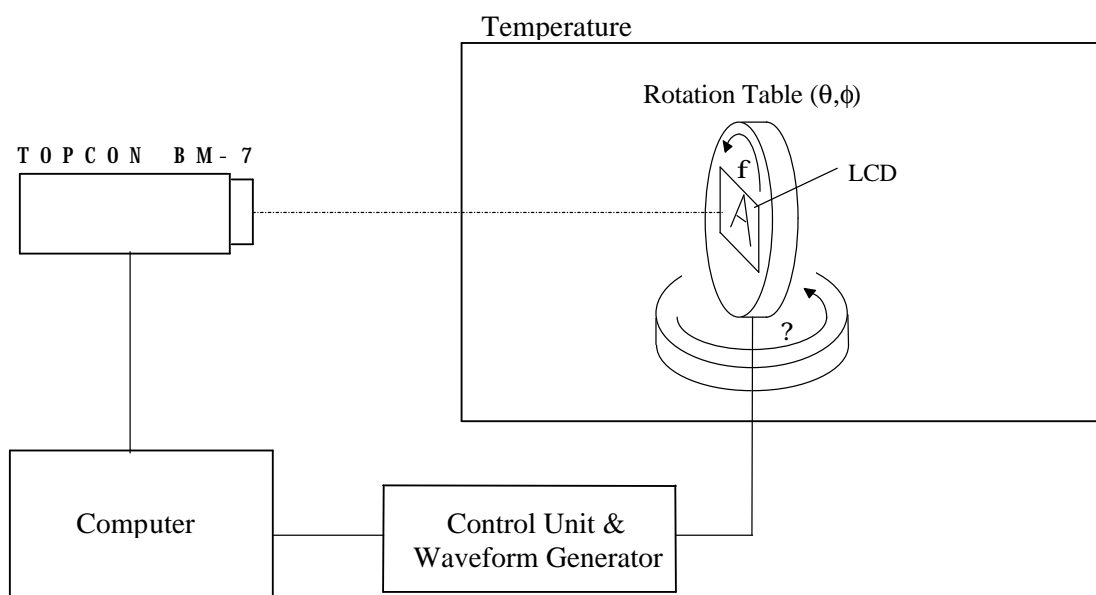

(4) Method of Measuring

Set rotation table to $\theta = 0^\circ$ and set BM-7 to contrast 10 to measure angle $\pm \theta$ for left and right direction of horizontal viewing angle f . Also set rotation table to $\theta = 90^\circ$ and set BM-7 to contrast 10 to measure angle $\pm \theta$ for up and down direction of vertical viewing angle f .

(Fig.5 - 4)

? Measuring Response Time

(1) Measuring Device

T O P C O N B M - 7 ? M e a s u r i n g F i e l d : 1 °

Tektronix Digital Oscilloscope

(2) Measuring Point

Center of display, same as Method of Brightness Measurement

(3) Method of Measuring

- Set LCD panel to $\theta = 0^\circ$, and $f = 0^\circ$.
- Input white? black? white to display by switching signal voltage.
- If the luminance is 0% and 100% immediately before the change of signal voltage, then t_r is optical response time during the change from 90% to 10% immediately after rise of signal voltage, and t_d is optical response time during the change from 10% to 90% immediately after decay of signal voltage.

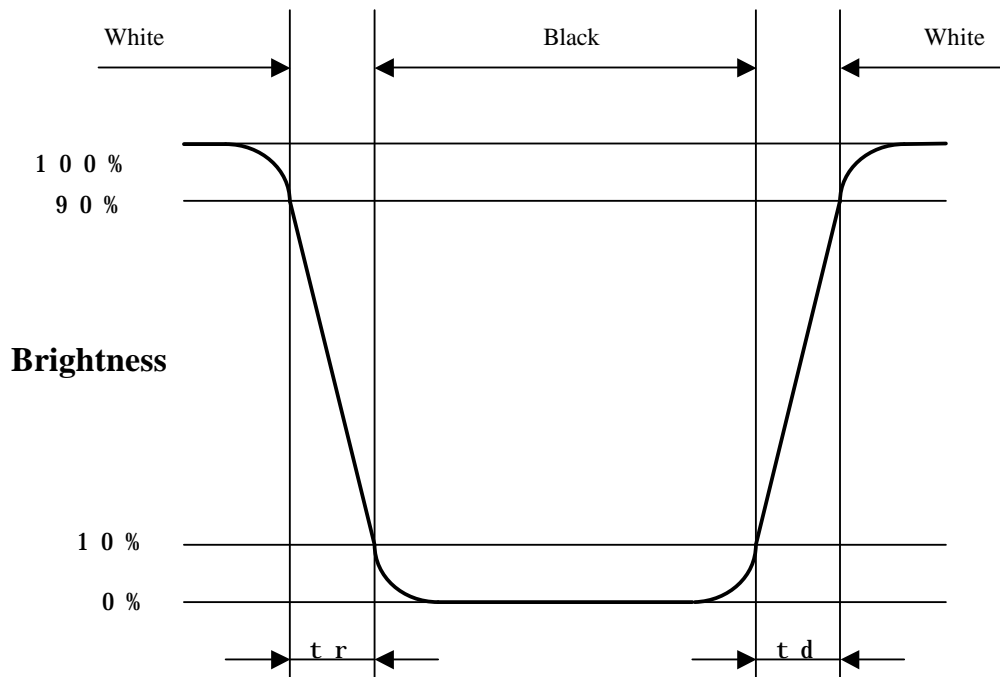

Preliminary

6. Electrical Characteristics

6.1 Recommended Operating Conditions

(T a = 25± 5? ? V ss= 0V)

Item	Symbol	Condition	Min.	Typ.	Max.	Unit	
Power Supply	System	V _{PW}	8.0	12.0	16.0	V	
	Backlight	V _{BL}	8.0	12.0	16.0	V	
Input Signals	Composite Video	VIDEO	750	1.0		V _{p-p}	
	Analog RGB	R,G,B		0.7		V _{p-p}	
	Chroma Signal	YCSYNC		1.0		V _{p-p}	
	Synchronous Signals	HSY,VSY		0.7		V _{p-p}	
	Brightness	BRT		2.6		V	
	Tint	TINT	1.0	2.7		V	
	Color	COLOR		2.5		V	
	Contrast	CONT		2.5		V	
	Backlight	DIM		1		100	%
	Select Signals	MOD1~ 3,N/P U/D,R/CMP R/L,YC/CMP	H level	3.0		3.6	V
		L level	0		0.8		
Synchronous Frequency	f _{V_{DN}}	NTSC	57.14	59.939	62.86	Hz	
	f _{H_{DN}}		15.00	15.734	16.50	KHz	
	f _{V_{DP}}	PAL	48.64	50.00	51.20	Hz	
	f _{H_{DP}}		15.20	15.625	16.00	KHz	

Note: Recommended Operating Conditions defines the guaranteed range of operation and it is out of guarantee if the product exceeds the range even if within the range of Item3.Absolute Maximum Ratings. Please use within the range of Recommended Operating Conditions.

6.2 Pixel Alignment

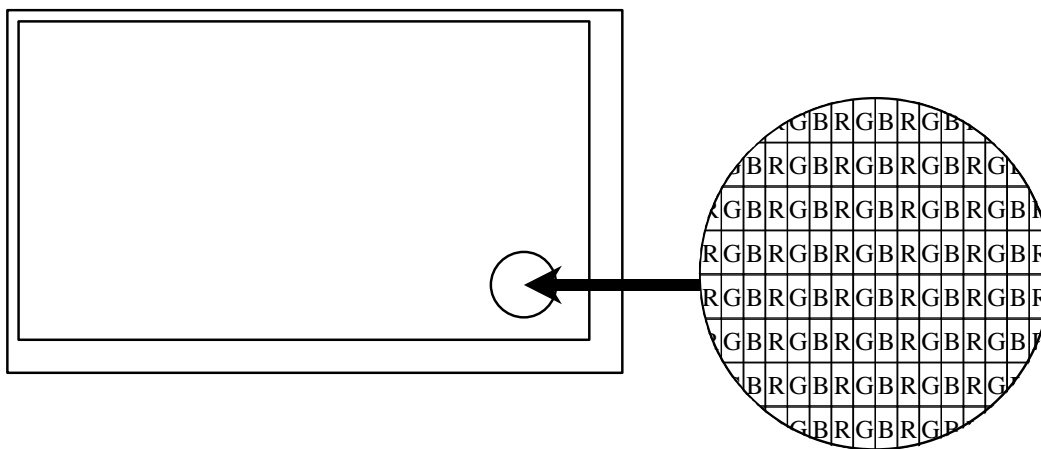

6.3 I/O Terminal Descriptions

Preliminary

No.	Symbol	Level	Function	I/O	Remark
1	V _{DD}	?	Power Supply (+5V)	Output	
2	COLOR	?	Color Adjustment (0~ 5V)	Input	
3	BRT	?	Brightness Adjustment (0~ 5V)	Input	
4	CONT	?	Contrast Adjustment (0~ 5V)	Input	
5	VIDEO	?	Composite Video Signal Input (1.0V _{P-P,750})	Input	
6	V _{SS}	?	Signal Ground	?	
7	V _{SS}	?	Backlight Ground	?	
8	V _{SS}	?	Backlight Ground	?	
9	V _{BL}	?	Power Supply for Backlight (+8~ 16V)	Input	
10	V _{BL}	?	Power Supply for Backlight (+8~ 16V)	Input	
11	U/D	H / L	Up/Down Scanning Direction (Open:Down to Up, GND:Up to Down)	Input	
12	R/L	H / L	Left/Right Scanning Direction (Open: Left to Right, GND: Right to Left)	Input	
13	DIM	?	Backlight Dimming (1~ 100% Adjustable)	Input	
14	MOD1	H / L	Display Mode 1	Input	
15	MOD2	H / L	Display Mode 2	Input	
16	MOD3	H / L	Display Mode 3	Input	
17	N/P	H / L	NTSC/PAL Select (Open : NTSC, GND : PAL)	Input	
18	TINT	?	Tint Adjustment (1~ 5V)	Input	
19	R/CMP	H / L	RGB/Composite Select (Open: RGB, GND:Composite)	Input	
20	YC/CMP	H / L	Synchronous Signal Select (Open: YC Separate, GND: Composite)	Input	
21	YCSYNC	?	Chroma Signal (0.7V _{P-P,750})	Input	
22	VS _Y	?	Vertical Sync. (0.7V _{P-P,750} , Active Low)	Input	
23	HS _Y	?	Horizontal Sync. (0.7V _{P-P,750} , Active low)	Input	
24	V _{SS}	?	Signal Ground	?	
25	G	?	Green Color Video Signal (1.0V _{P-P,750})	Input	
26	B	?	Blue Color Video Signal (1.0V _{P-P,750})	Input	
27	R	?	Red Color Video Signal (1.0V _{P-P,750})	Input	
28	V _{PW}	?	System Power Supply (+8~ 16V)	Input	
29	VS _{YO}	?	Vertical Sync.Output (0.7V _{P-P,750} ,Active Low)	Output	
30	HS _{YO}	?	Horizontal Sync.Output (0.7V _{P-P,750} ,Active Low)	Output	

Mating Connector : SHDR-30V-S-B (JST)

6.4 Block Diagram

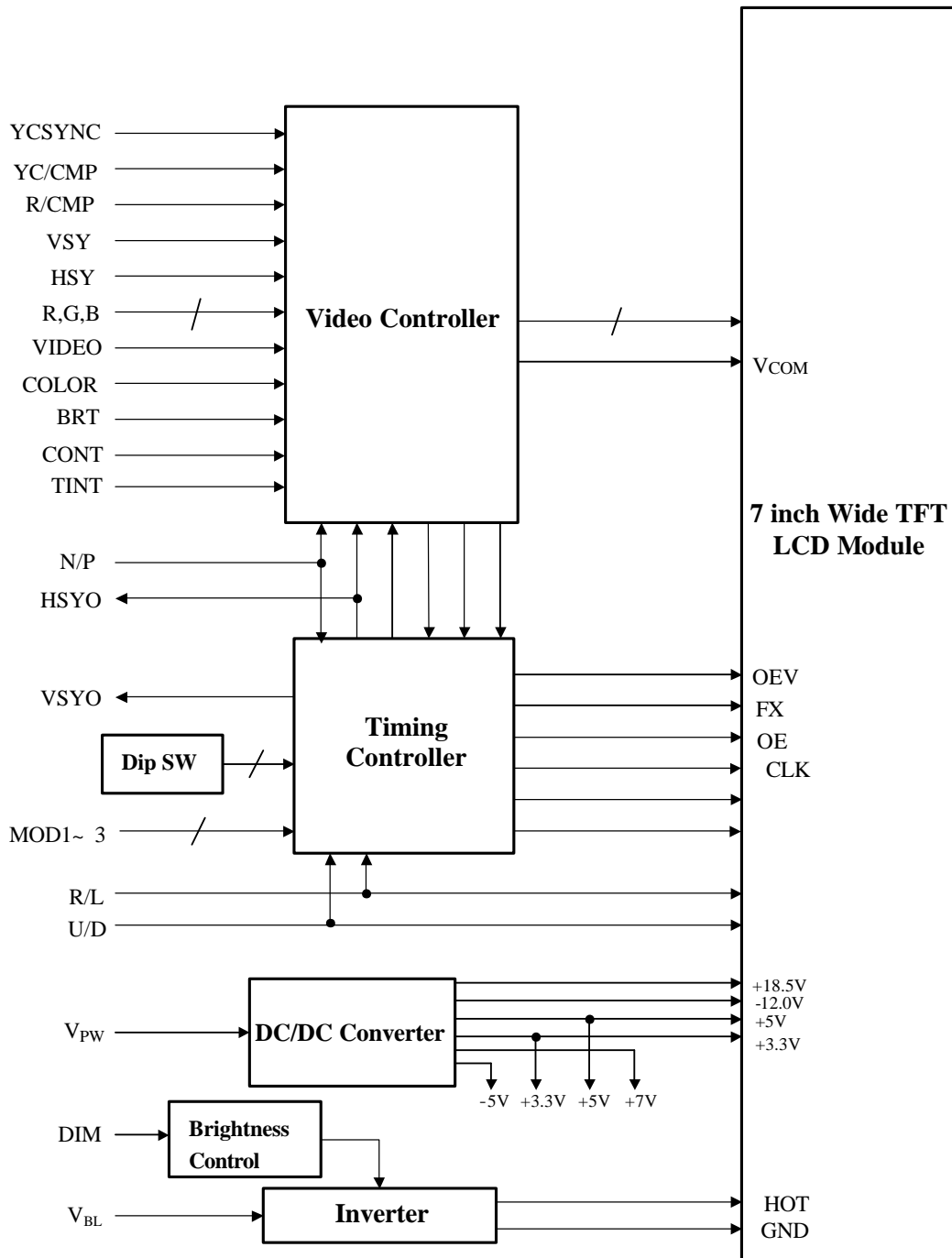

6.5 Signal Definition

Pin No.	Symbol	Function	I/O Internal Equivalent Circuit
1	V _{DD}	5V output terminal Please use this for each adjustable terminal (2 ~ 4, 18 pin)	Output Current(I _{dd}) = Less than 10mA
2	COLOR	Color adjustment input terminal. Can be selected to change anywhere between 0 ~ 5V.	
3	BRT	Brightness Adjustment for RGB signal. Can be selected to change anywhere between 0 ~ 5V.	
4	CONT	Contrast adjustment terminal. Can be selected to change anywhere between 0 ~ 5V.	
5	VIDEO	Composite video signal input terminal. Please use standard input level 1 Vp-p of composite video signal. When using composite video input signal fix YCSYNC(21pin) to GND .	
6	V _{ss}	Signal Ground terminal. Connect to GND.	_____
7	V _{ss}	Backlight grounding terminal. Connect to GND.	_____
8	V _{ss}	Backlight grounding terminal. Connect to GND.	_____
9	V _{BL}	Power supply input terminal for backlight. Use standard 12V.	_____
10	V _{BL}	Power supply input terminal for backlight. Use standard 12V.	_____
11	U/D	Up/Down scanning direction select terminal. When open, it will scan down to up. When connected to GND, it will scan up to down.	
12	R/L	Left/Right scanning direction select terminal. When open, it will scan left to right. When connected to GND, it will scan right to left.	

Pin No.	Symbol	Function	I/O Internal Equivalent Circuit
13	DIM	Backlight Dimming Terminal. Input 3.3V square wave PWM format	
14	MOD 1	Display mode select input terminal	
15	MOD 2	See Table 6.1	
16	MOD 3		
17	N/P	NTSC/PAL select terminal. Open : NTSC GND : PAL	
18	TINT	Tint adjustment input terminal. Can be selected between 1~5V	
19	R/CMP	Video signal input select terminal. Open: Analog RGB GND: Composite Video	
20	YC/CMP	Synchronous signal input select terminal. Open: YC separate input GND: Composite	
21	YCSYNC	Chroma input terminal. Use Chroma signal 0.7Vp-p. When using composite video, connect to GND.	
22	VSY	Vertical synchronous signal input terminal.	
23	HSY	Horizontal synchronous signal input terminal.	
24	Vss	Signal Ground terminal. Connect to GND.	
25	G	Analog RGB signal input terminal.	
26	B	Use Analog RGB signal standard level	
27	R	0.7Vp-p.	
28	PWR	System power supply input terminal. Use standard 12V.	
29	VSYO	Vertical synchronous signal output terminal. Please use for UOS(under on screen) to adjust the screen position.	
30	HSYO	Horizontal synchronous signal output terminal. Please use for UOS(under on screen) to adjust the screen position.	

Table 6.1 : Display Mode

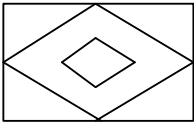
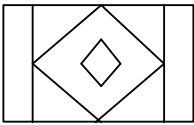
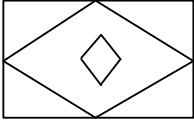
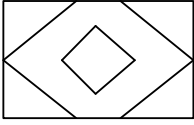
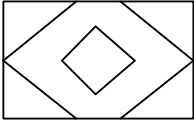
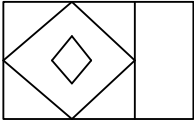
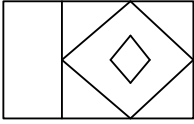
Mode	Display Image (4:3 Signal Input)	MOD1 (14pin)	MOD2 (15pin)	MOD3 (16pin)	Remark
Full		GND	GND	GND	Input Signal is displayed fully on screen.
Normal Center		OPEN	GND	GND	4:3 Image displayed in center of display.
Wide		GND	OPEN	GND	4:3 Signal has been extended sideways from center of display.
Zoom 1		OPEN	OPEN	GND	Display is fixed on top and then zoomed.
Zoom 2		GND	GND	OPEN	The time for gate is adjusted from Zoom1 mode.
Normal Left		OPEN	GND	OPEN	4:3 image shifted to left.
Normal Right		GND	OPEN	OPEN	4:3 image shifted to right.
Unfixed		OPEN	OPEN	OPEN	Unfixed

6.6 Timing specification (Analog RGB)

Fig.6-1 Full/Wide/Zoom1,2 mode

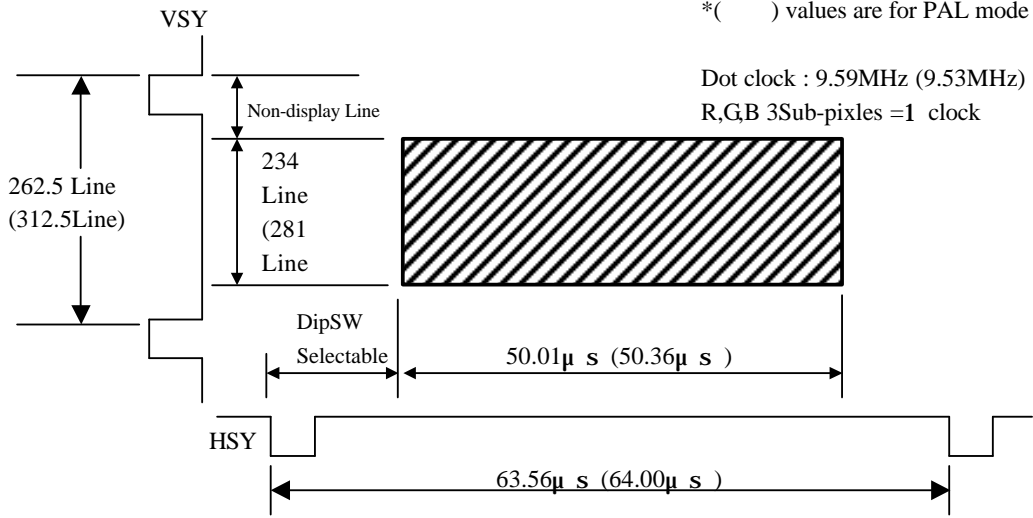

Note: Display mode and DipSW setting can change non-display lines and display lines.

Fig6-2 4:3 mode (Center/Right/Left)

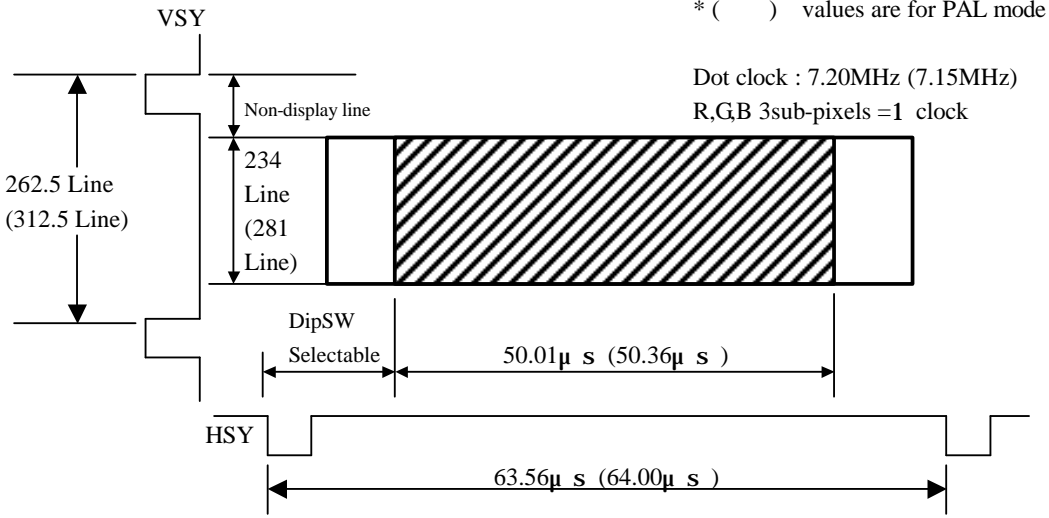

Note: Normal left/right has same value as Normal center values as above.

Preliminary

Fig. 6-3 (Horizontal Timing (NTSC/PAL))

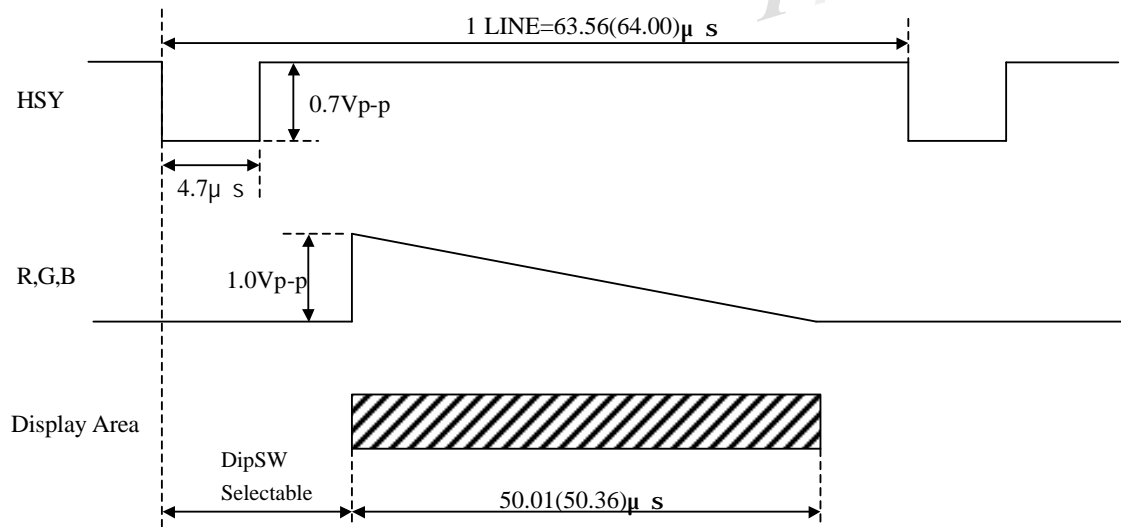

Note : All values are set at typical.

Values within () are values for PAL mode.

Fh=15.734(15.625) kHz

Fig.6-4 Vertical Timing (NTSC: Full/4:3mode)

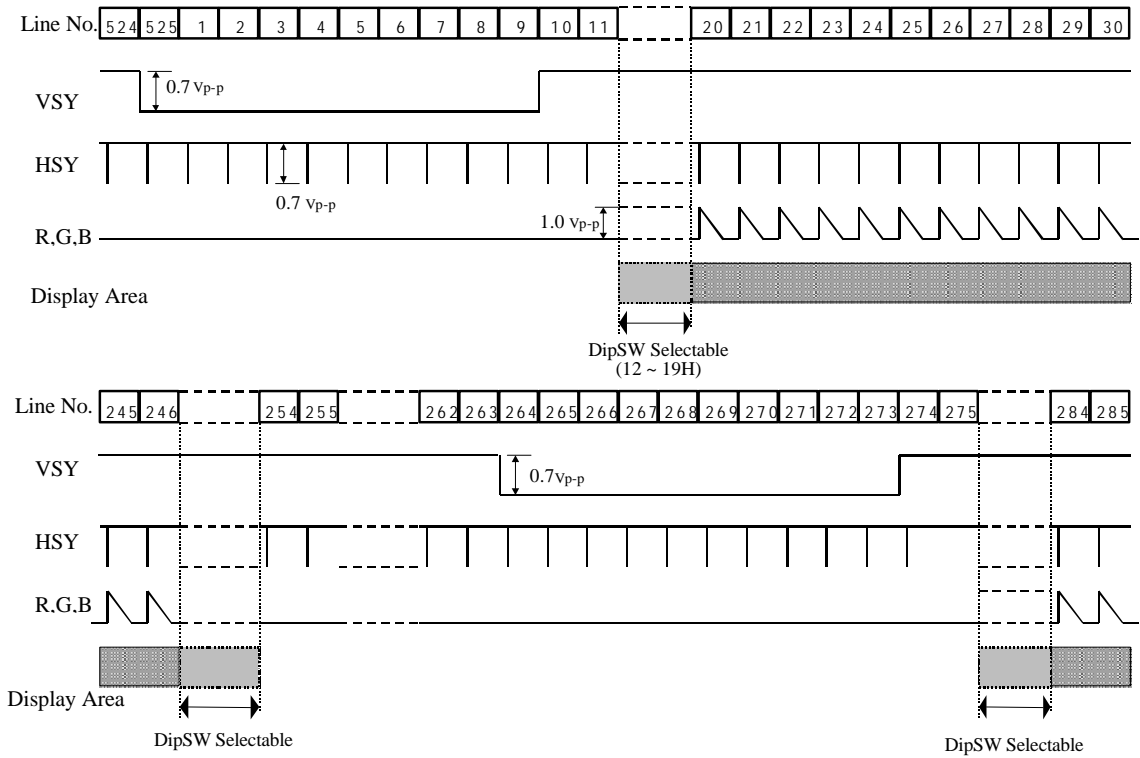

Note: Wide/Zoom mode has different starting location

6.7 Video Board Adjustment

6.7.1 Dip Switch (SW 1,2)

Dip Switch Number	Contents	Remark																																																																																																															
S W 1	Horizontal Display Starting Position Adjust(From HSY) SW1 4 3 2 1 Wait Time	Default Set SW1-1 : ON SW1-2 : OFF SW1-3 : ON SW1-4 : OFF SW1-5 : OFF SW1-6 : OFF SW1-7 : OFF SW1-8 : ON																																																																																																															
	<table border="1"><tr><td>OFF</td><td>OFF</td><td>OFF</td><td>OFF</td></tr><tr><td>OFF</td><td>OFF</td><td>OFF</td><td>ON</td></tr><tr><td>OFF</td><td>OFF</td><td>ON</td><td>OFF</td></tr><tr><td>OFF</td><td>OFF</td><td>ON</td><td>ON</td></tr><tr><td>OFF</td><td>ON</td><td>OFF</td><td>OFF</td></tr><tr><td>OFF</td><td>ON</td><td>OFF</td><td>ON</td></tr><tr><td>OFF</td><td>ON</td><td>ON</td><td>OFF</td></tr><tr><td>OFF</td><td>ON</td><td>ON</td><td>ON</td></tr><tr><td>ON</td><td>OFF</td><td>OFF</td><td>OFF</td></tr><tr><td>ON</td><td>OFF</td><td>OFF</td><td>ON</td></tr><tr><td>ON</td><td>OFF</td><td>ON</td><td>OFF</td></tr><tr><td>ON</td><td>OFF</td><td>ON</td><td>ON</td></tr><tr><td>ON</td><td>ON</td><td>OFF</td><td>OFF</td></tr><tr><td>ON</td><td>ON</td><td>OFF</td><td>ON</td></tr><tr><td>ON</td><td>ON</td><td>ON</td><td>OFF</td></tr> <tr> <td></td> <td>2.6125uS(3.8125uS)</td> <td></td> </tr> <tr> <td></td> <td>() values are for PAL mode, other values at side black</td> <td></td> </tr> <tr> <td></td> <td>Vertical Display Starting Position Adjust(From VSY) SW1 7 6 5 Start Line=12H</td> <td></td> </tr> <tr> <td></td> <td><table border="1"><tr><td>OFF</td><td>OFF</td><td>OFF</td></tr><tr><td>OFF</td><td>OFF</td><td>ON</td></tr><tr><td>OFF</td><td>ON</td><td>OFF</td></tr><tr><td>OFF</td><td>ON</td><td>ON</td></tr><tr><td>ON</td><td>OFF</td><td>OFF</td></tr><tr><td>ON</td><td>OFF</td><td>ON</td></tr><tr><td>ON</td><td>ON</td><td>OFF</td></tr><tr><td>ON</td><td>ON</td><td>ON</td></tr></table></td> <td></td> </tr> <tr> <td></td> <td>12H(24H) 13H(25H) 14H(26H) 15H(27H) 16H(28H) 17H(29H) 18H(30H) 19H(31H)</td> <td></td> </tr> <tr> <td></td> <td>() values are for PAL mode, at zoom add31H(35H)</td> <td></td> </tr> <tr> <td></td> <td>SW1-8: Display Image Adjustment Select ON: Internal by Pots. OFF: External by level</td> <td></td> </tr> <tr> <td rowspan="4">S W 2</td> <td>SW2-1: ON(Default)</td> <td rowspan="4">Default Set SW2-1 : ON SW2-2 : ON SW2-3 : OFF SW2-4 : ON</td> </tr> <tr> <td>SW2-2: ON(Default)</td> </tr> <tr> <td>SW2-3: UOS(Under On Screen) Display Select ON: Active OFF: Non Active</td> </tr> <tr> <td>SW2-4: Synchronous Signal Select ON: Composite OFF: Analog RGB</td> </tr> </table>		OFF	OFF	OFF	OFF	OFF	OFF	OFF	ON	OFF	OFF	ON	OFF	OFF	OFF	ON	ON	OFF	ON	OFF	OFF	OFF	ON	OFF	ON	OFF	ON	ON	OFF	OFF	ON	ON	ON	ON	OFF	OFF	OFF	ON	OFF	OFF	ON	ON	OFF	ON	OFF	ON	OFF	ON	ON	ON	ON	OFF	OFF	ON	ON	OFF	ON	ON	ON	ON	OFF		2.6125uS(3.8125uS)			() values are for PAL mode, other values at side black			Vertical Display Starting Position Adjust(From VSY) SW1 7 6 5 Start Line=12H			<table border="1"><tr><td>OFF</td><td>OFF</td><td>OFF</td></tr><tr><td>OFF</td><td>OFF</td><td>ON</td></tr><tr><td>OFF</td><td>ON</td><td>OFF</td></tr><tr><td>OFF</td><td>ON</td><td>ON</td></tr><tr><td>ON</td><td>OFF</td><td>OFF</td></tr><tr><td>ON</td><td>OFF</td><td>ON</td></tr><tr><td>ON</td><td>ON</td><td>OFF</td></tr><tr><td>ON</td><td>ON</td><td>ON</td></tr></table>	OFF	OFF	OFF	OFF	OFF	ON	OFF	ON	OFF	OFF	ON	ON	ON	OFF	OFF	ON	OFF	ON	ON	ON	OFF	ON	ON	ON			12H(24H) 13H(25H) 14H(26H) 15H(27H) 16H(28H) 17H(29H) 18H(30H) 19H(31H)			() values are for PAL mode, at zoom add31H(35H)			SW1-8: Display Image Adjustment Select ON: Internal by Pots. OFF: External by level		S W 2	SW2-1: ON(Default)	Default Set SW2-1 : ON SW2-2 : ON SW2-3 : OFF SW2-4 : ON	SW2-2: ON(Default)	SW2-3: UOS(Under On Screen) Display Select ON: Active OFF: Non Active	SW2-4: Synchronous Signal Select ON: Composite OFF: Analog RGB
	OFF		OFF	OFF	OFF																																																																																																												
	OFF		OFF	OFF	ON																																																																																																												
	OFF		OFF	ON	OFF																																																																																																												
	OFF		OFF	ON	ON																																																																																																												
	OFF		ON	OFF	OFF																																																																																																												
	OFF		ON	OFF	ON																																																																																																												
	OFF		ON	ON	OFF																																																																																																												
	OFF		ON	ON	ON																																																																																																												
	ON		OFF	OFF	OFF																																																																																																												
	ON		OFF	OFF	ON																																																																																																												
	ON		OFF	ON	OFF																																																																																																												
	ON		OFF	ON	ON																																																																																																												
	ON		ON	OFF	OFF																																																																																																												
ON	ON	OFF	ON																																																																																																														
ON	ON	ON	OFF																																																																																																														
	2.6125uS(3.8125uS)																																																																																																																
	() values are for PAL mode, other values at side black																																																																																																																
	Vertical Display Starting Position Adjust(From VSY) SW1 7 6 5 Start Line=12H																																																																																																																
	<table border="1"><tr><td>OFF</td><td>OFF</td><td>OFF</td></tr><tr><td>OFF</td><td>OFF</td><td>ON</td></tr><tr><td>OFF</td><td>ON</td><td>OFF</td></tr><tr><td>OFF</td><td>ON</td><td>ON</td></tr><tr><td>ON</td><td>OFF</td><td>OFF</td></tr><tr><td>ON</td><td>OFF</td><td>ON</td></tr><tr><td>ON</td><td>ON</td><td>OFF</td></tr><tr><td>ON</td><td>ON</td><td>ON</td></tr></table>	OFF	OFF	OFF	OFF	OFF	ON	OFF	ON	OFF	OFF	ON	ON	ON	OFF	OFF	ON	OFF	ON	ON	ON	OFF	ON	ON	ON																																																																																								
OFF	OFF	OFF																																																																																																															
OFF	OFF	ON																																																																																																															
OFF	ON	OFF																																																																																																															
OFF	ON	ON																																																																																																															
ON	OFF	OFF																																																																																																															
ON	OFF	ON																																																																																																															
ON	ON	OFF																																																																																																															
ON	ON	ON																																																																																																															
	12H(24H) 13H(25H) 14H(26H) 15H(27H) 16H(28H) 17H(29H) 18H(30H) 19H(31H)																																																																																																																
	() values are for PAL mode, at zoom add31H(35H)																																																																																																																
	SW1-8: Display Image Adjustment Select ON: Internal by Pots. OFF: External by level																																																																																																																
S W 2	SW2-1: ON(Default)	Default Set SW2-1 : ON SW2-2 : ON SW2-3 : OFF SW2-4 : ON																																																																																																															
	SW2-2: ON(Default)																																																																																																																
	SW2-3: UOS(Under On Screen) Display Select ON: Active OFF: Non Active																																																																																																																
	SW2-4: Synchronous Signal Select ON: Composite OFF: Analog RGB																																																																																																																

6.7.2 Potentiometers for Display Image Adjustment

Symbol	Contents	Remark
VR301	TINT: Tint Adjustment	
VR302	COLOR: Color Adjustment	
VR305	CONT: Contrast Adjustment	
VR312	BRT: Brightness Adjustment	

7.Product Standard

7.1.Mechanical Testing

7.1.1.External appearance

Inspection Area	Item	Criteria	Remark
TFT Cell Section	Surface Linear Scratches	Thickness Disregard under 0.05mm Between 0.05mm-0.15mm, total length must be within 50mm Greater then 0.15mm is not acceptable	Note1 Note2
	Surface Sport Scratches	Disregard under 1 sub-pixel Penalized for 1-3 sub-pixels Shall not exceed 3 sub-pixels	
	Back Scratches	Observe from surface and judge based on criteria of surface	
	Chipped	It must not influence surface	
	Dirt	Must be removable	
	Discoloration	No irregular discoloration on screen	
Metal Shield case (Applies to all surface)	Linear Scratches	Thickness Disregard under 3.0mm Greater then 3.0mm must have less then 90mm total	Note2
	Spot Scratches	Diameter Less then 3.0mmf ,only 3 is allowed Greater then 3.0mmf is not accepted	
	Dirt	Must be removable	
	Deformation	Not allowed	
	Fingerprint	Remove as much as possible	
Input Output Section (FPC w/B/L Cable)	Crack	No crack or disconnection	Note3
	Distortion	No noticeable distortion	
	FPC tape	The FPC should not be coming off for more then 10mm	

Note1: Cell section's area subject to quality display area. Quality display area is specified in the external appearance drawing.

Note2: If there are any other problems please follow "Precautions under operation".

Note3: This is provisional standard and applies to limited sample (Optrex standards)

7.1.2.Dimensional Outline

All standards follow the measurement designated by the dimensional outline drawing.

7.2.Quality of Display

7.2.1.Conditions for Common Inspection

Unless specified, the conditions below will be applied.

Ta=25 ± 5? ? Humidity=65%? V_{PW}=V_{BL}=+12.0V? V_{SS}=0V? Backlight inverter=Our standard inverter or equivalent, measured after backlight has been lit for more then 30 minutes.

7.2.2.Quality Display Standard and Criteria for Judgement

(A) Quality Display Standard

Item		Description	Criteria
Quality Display	Line defect	Black, white and colored line	Not accepted
	Spot defect	Lighting irregularities due to sub-pixels by the TFT and CF. White spots: Any pixel that can be seen through ND(Neutral Density) filter when black signal(V _{sig} =4V) is inputted under specified condition. Black sports: Any pixel that is below 50% of maximum luminance when white signal(V _{sig} =0V) is inputted.	Refer to next section Note 2
Quality Screen	Stain	Luminance irregularities and discoloration spots.	Note 1,2
	Irregularity	Same as stain with more area.	
	Line	Same as stain but in linear shape.	
	Stripe	Same as stain, but in arc, spirals, or moiré shape.	
	Reverse	Others that are formed from concentration of irregular patterns.	

Note1: The quality of screen is set at V_{sig}=0V(white),2V(middle),4V(black)screen display and it may not be seen through 2.5% ND filter. However, for few exceptions, Sample under Optrex standard will be used for inspection.

Note2: When questions arise concerning this specifications or new problems that are not specified, it will be discussed for solution.

(B) Spot Defect Inspection Standards and Criteria.

White spots inspection criteria

7.2.1. Include below with the common inspection condition

- **Luminance:** 200~ 250 [lx]
- **Distance:** 45~ 50 [cm] (Perpendicular from panel surface)
- **Time:** 5 [S] (After ND filter has been placed)
- **Surface Brightness:** 300~ 320 [cd/m²]

Standard

Type	Acceptable No.	Criteria
Level 1 White Spots	0	Visible through 0.3%ND filter
Level 1-2 White Spots	3	Visible through 1.0%ND filter, and not visible through 0.3%ND filter
Level 1-3 White Spots	5	Visible through 2.5%ND filter, and not visible through 1.0%ND filter
Black spots	6	Any visible black spots on $V_{sig}=1V$ (All white cluster)
Total	7	Total white and black spots in level 1-3

Any spots that are not visible through 2.5% ND filters and not within level 1-3 is disregarded.

- ? Density:
 - Only up to 2(white or black) are allowed for diameter withinf 10mm.
 - If it is continuous, then continuous spot is applied.
- ? Continuous spot :
 - Any spot that continues for more then 3 pixels is not acceptable.
 - For 2 continuous white spots, treat as one spot for the table above.
 - For 2 continuous black spots, treat as two spots for the table above.
 - For 2 continuous white and black spot, treat as one each.
- ? White & black spot:
 - If the pixel holds both white and black spot (level 1-3), treat as white spot for the table above.
- ? Foreign Substance(within Cell):
 - Foreign substance shall not be more then 3-pixel size.
 - If the size of substance is 2 to 3-pixel, then count as 2 in acceptable value.
 - If the size of substance is 1 to 2-pixel, then count as 2 in acceptable value.
 - If the size of substance is smaller then 1 pixel, then disregard.

8. Reliability Test

8.1. Mechanical and Environmental Test

Pre

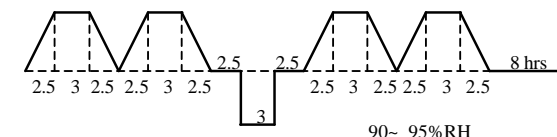
Item	Condition	Test hour	Remark	
Endurance	High temp operation	Ta=65± 2? , 45%RH Below	192 hrs	Note1
	High temp & high humidity operation	Ta=65± 2? , 90± 2%RH, No Condensation	192 hrs	Note1
	Low temp operation	Ta=-30± 3?	192 hrs	Note1
	High temp storage	Ta=85± 2? , 45%RH below	192 hrs	Note1
	Low temp storage	Ta=-40± 3?	192 hrs	Note1
	Light resistance	Sunshine carbon arc Ta=63± 2?	360 hrs	
Heat	Drastic temp change	-30? (60min)? 25? (15min)? 80? (60min), No electric path	20 cycle	Note2
	Condensation	-30? (30min non-operating), 25? /95%RH(10min operating) Dried after specified cycle and confirm operation	10cycle	
	Humidity cycle	1cycle= 48hrs non-operational 	5cycle	
Electrical	Static resistance	C=200pF, R=00 , V=± 150V 3 discharge on electric and other terminal, non-operational	-	
	Electric discharge	C=150pF, R=1500 , V=± 15kV Discharge ± charges 5 times each on panel and earth, non-operational	-	
Mechanical	Vibration	5~ 10Hz, width 25mm 10~ 30Hz, 3.7× 9.8m/s ² 30~ 50Hz, 1.6× 9.8m/s ² 50~ 80Hz, 0.7× 9.8m/s ² 80~ 100Hz, 0.3× 9.8m/s ²	X,Y,Z all dir 8min× 2sweep non-operational	All dir 96 hrs
	Shock	980m/s ² , t=6ms, X,Y,Z all dir, semi-sine-wave, non-operational	-	
	Terminal durability	Apply 500g of weight perpendicular to end of terminal Non-operational	-	
	External durability	Apply pressure on the center of the screen by push/pull gauge. head diameter isf 12mm? pressured apply 5× 9.8N(=5kgf) once, non-opreatioal	-	
	Pressure resistance	5× 10 ⁴ Pa(=0.5Pressure)? non-operational	2 hrs	

Note 1: High temperature operation, high temperature & high humidity operation, low temperature operation, high temperature storage and low temperature storage will test it's ability for 1000 hours to confirm. The deterioration of plarizer is disregarded.

Note 2: Drastic tempertaure change test will continue the inspection under same condition consecutiely to confirm it's ability. Test will be done mounted in your request kit.

8.2. Reliability Test Standard

Preliminary

Item		Optical & Electrical Characteristics				Quality of Screen
		Contrast	Surface luminance	Response time	Circuit	
Endurance	High temp operation*	>30	within \pm 20%	within \pm 20%	Within+ 40%	Not to be conspicuous
	High temp & high humidity operation*	>25	?	?	?	?
	Low temp operation*	>30	?	?	?	?
	High temp storage*	?	?	?	?	?
	Low temp storage*	?	?	?	?	?
	Light resistance*	?	?	?	?	?
Heat	Drastic temp change*	?	?	?	?	?
	Condensation?	>25	?	?	?	?
	Temp.& Humidity cycle?	?	?	?	?	?
Electrical	Static resistance	No abnormalities in system and display.				
	Electric discharge	No damage should be done				
Mechanical	Vibration	No abnormalities in system and display.				
	Shock	No abnormalities in system and display.				
	Exterior durability	No abnormalities in system and display.				
	Pressure durability	No abnormalities in system and display.				

Note: * indicates that test was performed in room temperature, more than 2 hours after it was taken out from chamber.

? indicates that test was performed after 24 hours after it has been taken out from chamber.

Luminance, circuit, response time changes are compared from the initial standard values.

9.Code System of Production Lot

9.1.Production Lot Number

Module's production Lot Number will be indicated as below.

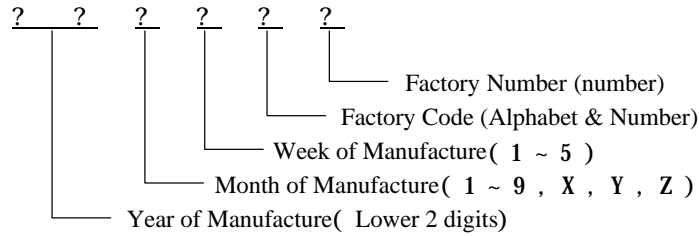

9.2.Type Number

The type number of module is specified on the back of module as follows;

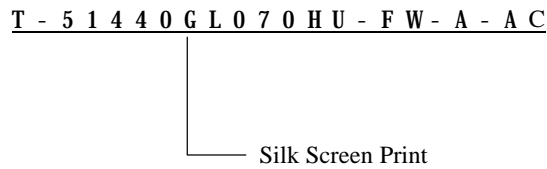

9.3.Precautions under Operation

When questions arise concerning this specifications or new problems not specified in this specifications arise, problems related to the specification is to be discussed for solution.

Preliminary

10.Packing Specification

T B D

Preliminary



11. Product Handling Cautions

In order to use the products properly please note the following precautions.

1) For LCD screen

- ? LCD particles used in LCD module is made into form of glass board. Do not apply any strong physical shock.
If it cracks, handle with extra caution to avoid any harm.
- ? The polarizer attached on the surface of LCD particles are composed by soft materials. Please do not scratch them.

2) Handling LCD module (static electricity countermeasure)

- ? Please ground all human bodies and electrical facilities. Also on the operation line, anti-static electricity mat (rubber) is recommended to avoid electric shock in case of accident.
- ? Working uniform should avoid synthetic fiber and recommend the use of cotton or non-electrical conducting fiber.
- ? When removing protective film from LCD panel, please remove it slowly to avoid development of static electricity.

3) For Storing Single LCD module for long term

- ? Do not store under high temperature and high humidity.
- ? Do not expose the module to direct sunlight or intensive ultraviolet rays for many hours.
- ? Avoid any force applied from external environment.

4) LCD module does not have circuit for over current protection. For in case of accident, please use power supply with over current protection.

5) If LCD panel breaks, it is possible that the liquid crystal leaks from the panel. Avoid putting it into eyes or mouth. When liquid crystal sticks on hands, clothes, or feet. Wash it out immediately with soap.

6) When using product with metal holder, if metal holder and the body are not soldered, sooth electric flow is not guaranteed. To secure the flows of electricity, please consult.

7) For products that requires the use of C F L

- ? On the connection of CFL cable more then 1000 v high voltage is applied. Please handle with care to avoid any burn upon contact.
- ? Please be careful if overcoat of CFL cable is in the status of abrasion by the contact with the system.
- ? Continuous use of CFL at low temperature, will shorten longevity of CFL compared to it's use at room temperature.

8) For products that uses touch panel

- ? Do not stack panel on top of each other. There may be possibility of harm caused by the edge of panel.
- ? Do not place any heavy objects above panel.

9) For product that uses COG, TAB, and COF

- ? The back side of IC hip is exposed and has low intensity. Upon handling, do not apply powerful pressure to the IC chip.
- ? IC chip backside is exposed and should not be equipped with any setup that releases electrical contact to prevent electrical damage. Also to prevent unintentional function by light and to keep it's electrical characteristics, set up to avoid exposure to light.

10) For product that uses FPC, heal seal and TAB

- ? To maintain reliability, do not hold onto connection section. Do not bend or pull lines with strong power. It could snap the lines.

12. Condition for Guarantee.

Our product is designed and manufactured by your specification requirement as a part for final electrical products. We will guarantee the product has no sign of defect and meet all qualifications of your request. However, if the final product was not for common household use, but instead used for medical, nuclear controller, aviation, disaster prevention or any other products that require extreme reliability, we can not be held responsible for any quality guarantee issue.

If the product was placed for any of the use above, we ask for revision on our contract for manufacturing this product.

- 1) After delivery, any modification (including restructure and taking apart) of the product we can not hold any responsibility for quality guarantee issue.
- 2) Any damage caused by the outside force, we can not hold any responsibility for quality guarantee issue.
- 3) After completing all product inspection and after delivery from the factory, any static electricity applied on product, we can not hold any responsibility for quality guarantee issue.
- 4) Upon using product with CFL, longevity and luminance may altar by the performance of inverter or leakage. We can not hold any responsibility for quality guarantee issue by performance or reliability of final product.
- 5) Any product that uses our product within, we will not hold any responsibility for any problems that has no relationship with the structure or performance of our product.