

MA2X707

Silicon epitaxial planar type

For UHF mixer

■ Features

- Small forward voltage V_F
- Optimum for UHF mixer because of its large conversion gain (GC)
- Mini type package, allowing downsizing of equipment and automatic insertion through the taping package

■ Absolute Maximum Ratings $T_a = 25^\circ\text{C}$

Parameter	Symbol	Rating	Unit
Reverse voltage (DC)	V_R	5	V
Forward voltage	V_F	0.5	V
Junction temperature	T_j	125	$^\circ\text{C}$
Storage temperature	T_{stg}	-55 to +125	$^\circ\text{C}$

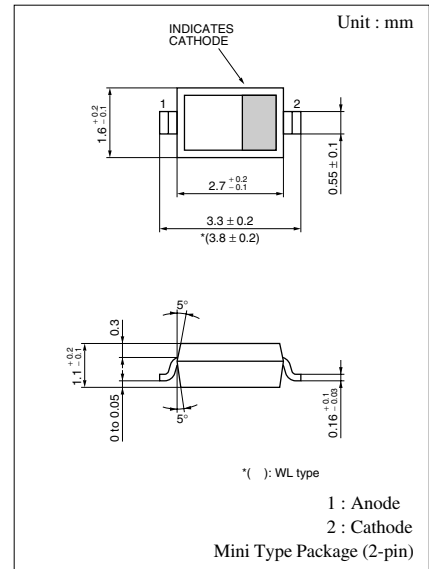

Marking Symbol: 5B

■ Electrical Characteristics $T_a = 25^\circ\text{C}$

Parameter	Symbol	Conditions	Min	Typ	Max	Unit
Forward current (DC)	I_F	$V_F = 0.5 \text{ V}$	35		100	mA
Reverse current (DC)	I_R	$V_R = 5 \text{ V}$			35	μA
Forward voltage (DC)	V_F	$I_F = 2 \text{ mA}$		0.25		V
Reverse break down voltage (DC)	$V_{(BR)R}$	$I_R = 1 \text{ mA}$	5			V
Terminal capacitance	C_t	$V_R = 0.5 \text{ V}, f = 1 \text{ MHz}$	0.65	0.85	1.05	pF
Conversion gain*1,2	GC	$R_F = 890 \text{ MHz}, L_O = 935 \text{ MHz}, I_F = 45 \text{ MHz}$	-7	-5		dB
Static breakdown strength		$C = 100 \text{ pF}$, Breakdown judgment point $I_R \geq 35 \mu\text{A}$	100	200		V

Note) 1. Schottky barrier diode is sensitive to electric shock (static electricity, etc.). Due attention must be paid on the charge of a human body and the leakage of current from the operating equipment

2. Noise figure is 8.5 dB.

3. Rated input/output frequency: 935 MHz

4. *1 : Judgement is to be made per each chip lot. Sampling of LTPD = 20% and $n = 11$ is guaranteed.

*2 : Set min. GC = -7 dB. Out-spec products, if any, this specification would be reviewed

