

CNZ1120

Photo Interrupter

For contactless SW, object detection

Overview

CNZ1120 is a photocoupler in which a high efficiency GaAs infrared light emitting diode is used as the light emitting element, and a high sensitivity phototransistor is used as the light detecting element. The two elements are arranged so as to face each other, and objects passing between them are detected.

Features

- Wide gap between emitting and detecting elements, suitable for thick plate detection Gap : 10mm
- Fast response : $t_r, t_f = 6 \mu s$ (typ.)
- The external case is molded using visible light cutoff resin. The case has no openings, so the photosensor is not easily susceptible to output attenuation resulting from dust or particles

Absolute Maximum Ratings (Ta = 25°C)

Parameter		Symbol	Ratings	Unit
Input (Light emitting diode)	Reverse voltage (DC)	V_R	3	V
	Forward current (DC)	I_F	50	mA
	Power dissipation	P_D^{*1}	75	mW
Output (Photo transistor)	Collector current	I_C	20	mA
	Collector to emitter voltage	V_{CEO}	20	V
	Emitter to collector voltage	V_{ECO}	5	V
	Collector power dissipation	P_C^{*2}	100	mW
Temperature	Operating ambient temperature	T_{opr}	-5 to +60	°C
	Storage temperature	T_{stg}	-15 to +65	°C

Electrical Characteristics (Ta = 25°C)

Parameter		Symbol	Conditions	min	typ	max	Unit
Input characteristics	Forward voltage (DC)	V_F	$I_F = 50mA$		1.2	1.5	V
	Reverse current (DC)	I_R	$V_R = 3V$			10	μA
Output characteristics	Collector cutoff current	I_{CEO}	$V_{CE} = 10V, I_F = 0mA, I_D = 0mA^{*1}$			200	nA
	Collector to emitter capacitance	C_C	$V_{CE} = 10V, f = 1MHz$		5		pF
Transfer characteristics	Collector current	I_C	$V_{CE} = 10V, I_F = 20mA, R_L = 100\Omega$	1.0			mA
	Response time	t_r, t_f^{*2}	$V_{CC} = 10V, I_C = 1mA, R_L = 100\Omega$		6		μs
	Collector to emitter saturation voltage	$V_{CE(sat)}$	$I_F = 50mA, I_C = 0.1mA$			0.4	V

*1 I_D : Leakage current due to scattered light

*2 Switching time measurement circuit

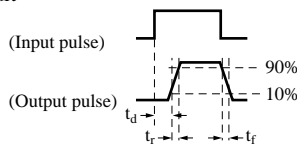
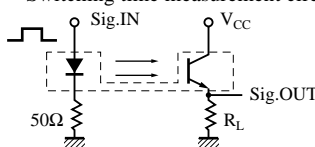

t_d : Delay time

t_r : Rise time (Time required for the collector current to increase from 10% to 90% of its final value)

t_f : Fall time (Time required for the collector current to decrease from 90% to 10% of its initial value)

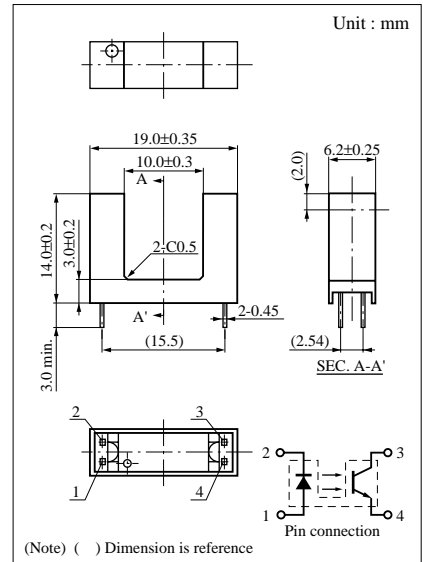

(Note) () Dimension is reference