

LNCQ03PS

Red Light Semiconductor Laser

For optical control systems

■ Features

- High output operations with oscillating wavelength of 660nm : 35mW
- Low threshold current
- Stable single horizontal mode oscillation
- Space saved by miniaturization
- Low astigmatic difference facilitates good concentrated light spot, production.

■ Applications

- DVD-Ram
- Pointer

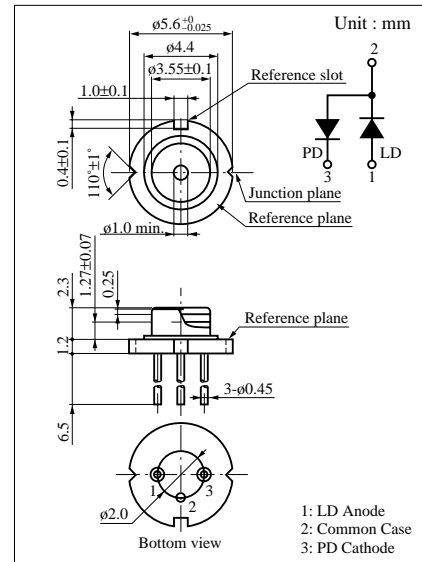

■ Absolute Maximum Ratings (Ta = 25°C)

Parameter		Symbol	Rated	Unit
Radiant power		P_O	35	mW
Reverse voltage	Laser	V_R	1.5	V
	PIN	V_R (PIN)	30	V
Power dissipation		P_d (PIN)	60	mW
Operating ambient temperature		T_{opr}	-10 to +60	°C
Storage temperature		T_{stg}	-40 to +85	°C

■ Electro-Optical Characteristics (Ta = 25°C)

Parameter		Symbol	Conditions	min	typ	max	Unit
Threshold current		I_{th}	CW	20	50	70	mA
Operating current		I_{OP}	CW $P_O = 30mW$	50	95	120	mA
Operating voltage		V_{OP}	CW $P_O = 30mW$	2.0	2.5	3.0	V
Resistance between electrodes		R_S	CW $P_O = 30mW$	3.0	5.0	10	Ω
Oscillation wavelength		λ_L	CW $P_O = 30mW$	635	660	675	nm
Slope efficiency		SE	CW $P_O = 30mW$	0.5	0.7	1.1	W/A
Radiation angle	Horizontal direction	$\theta_{//}$	CW $P_O = 30mW$	7.5	8.5	10.5	deg.
	Vertical direction	θ_{\perp}	CW $P_O = 30mW$	17	22	26.5	deg.
Optical axis accuracy	X direction	θ_X	CW $P_O = 30mW$	-2.0		+2.0	deg.
	Y direction	θ_Y	CW $P_O = 4mW$	-3.0		+3.0	deg.
Astigmatic difference		As^{*2}	CW $P_O = 4mW$		5.0	10	μm

*1 $\theta_{//}$ and θ_{\perp} are the angles where the optical intensity is a half of its max. value. (half full angle)

*2 Reference to package axis.

*3 Guaranteed value in design.

