

MN838850

Source Driver for LCD Panel Drive

■ Overview

The MN838850 converts digital display data from a personal computer or an engineering workstation to analog signal voltages to allow those signals to be displayed on a color TFT LCD panel.

■ Features

- Includes a built-in D/A converter and accepts 8-bit digital input data for 16.7-million color display.
- Output dynamic range: 14.6 V_{P-P} (when AVDD = 15 V)
- Supports both dot inversion drive and source inversion drive schemes.
- Number of drive outputs: 384
- Input data bus: acquires two pixels at the same time
- Supports control of data inversion at each clock cycle.
- Supports γ correction.
- Adopts a drive scheme that does not require precharging.
- Allows serial cascade connection.
- The clock is automatically stopped after the acquisition of a fixed amount of data.
- The shift register shift direction can be set to be either left-to-right or right-to-left.
- Digital circuit block features low-voltage operation:
2.7 to 3.6 V
- Maximum operating clock frequency:
50 MHz (3.1 to 3.6 V), 40 MHz (2.7 to 3.6 V)

■ Applications

- TFT LCD panels

■ Block Diagram

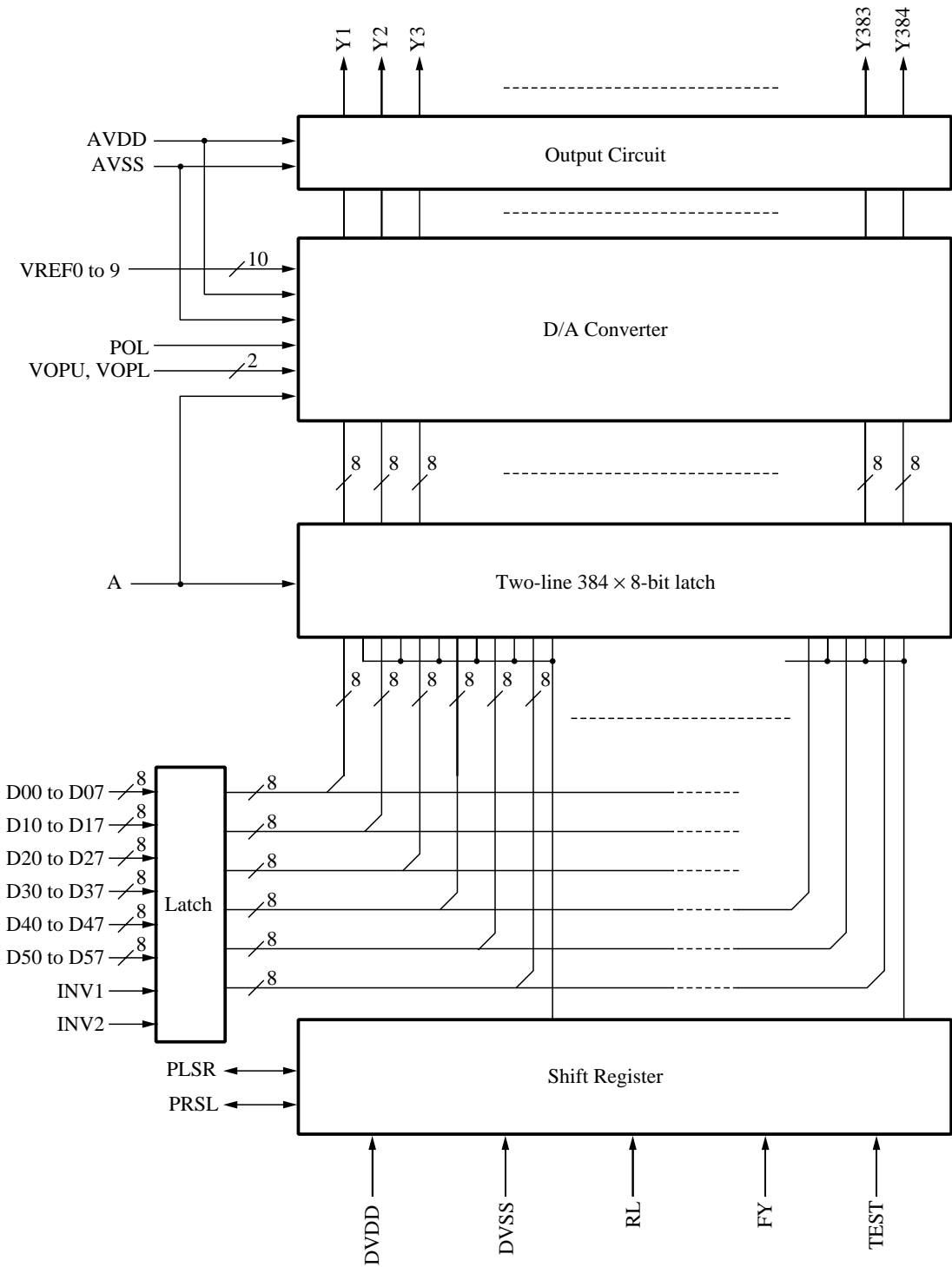

■ Pin Arrangement

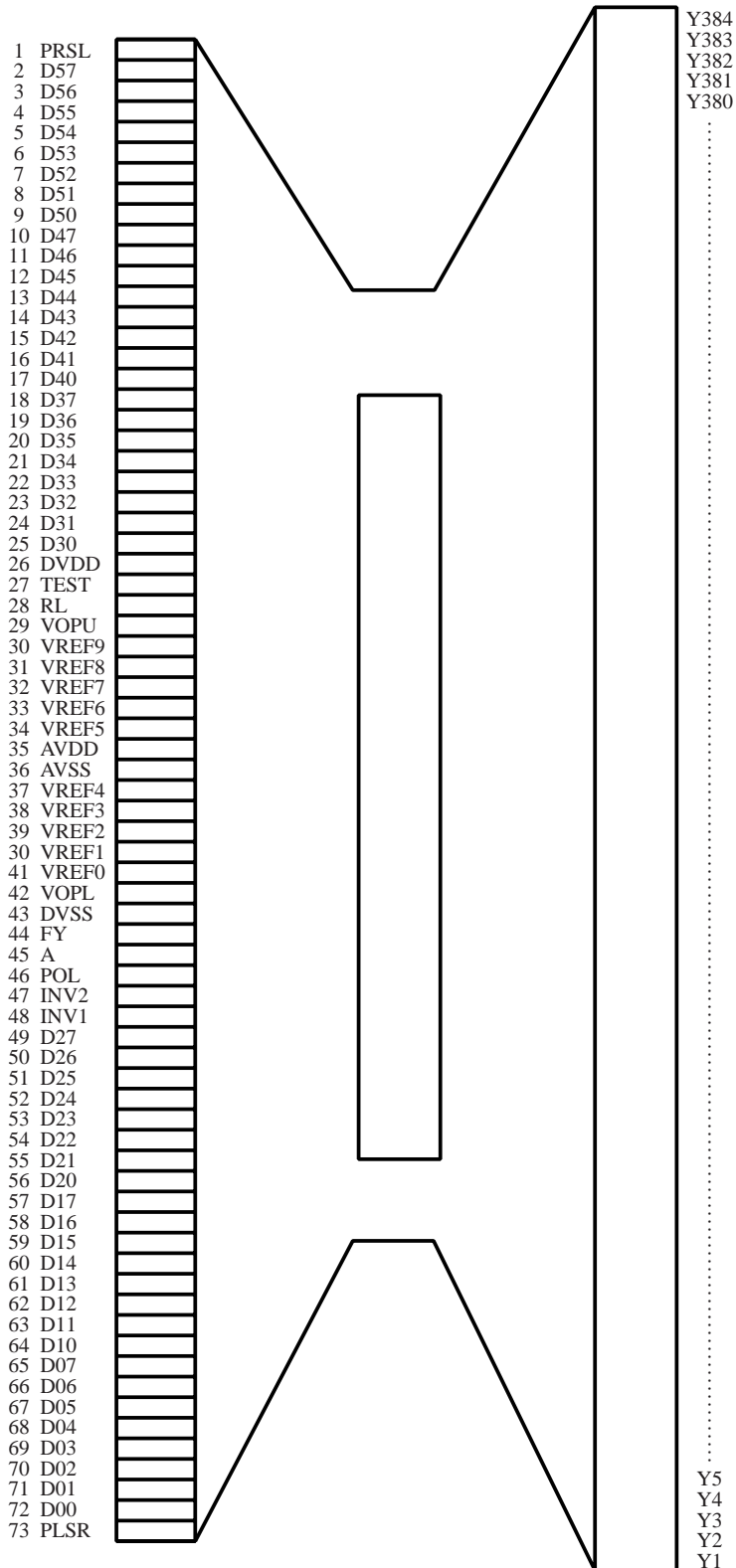

Cu Foil Surface Top View

■ Pin Descriptions

Pin No.	I/O	Pin Name	Description									
D00 to D07 D10 to D17 D20 to D27 D30 to D37 D40 to D47 D50 to D57	I	Image data input	Image data input pins. The R, G, and B image signals are input using these pins. D07, D17, D27, D37, D47, D57 : MSB D00, D10, D20, D30, D40, D50 : LSB									
Y1 to Y384	O	Image signal output	Analog image signal output pins.									
PLSR PRSL	I/O	Start pulse input and output	Internal shift register start pulse input and output pins. <table border="1" style="width: 100%; border-collapse: collapse;"> <thead> <tr> <th></th> <th>RL = "H"</th> <th>RL = "L"</th> </tr> </thead> <tbody> <tr> <td>PLSR</td> <td>Right shift input</td> <td>Left shift output</td> </tr> <tr> <td>PRSL</td> <td>Right shift output</td> <td>Left shift input</td> </tr> </tbody> </table>		RL = "H"	RL = "L"	PLSR	Right shift input	Left shift output	PRSL	Right shift output	Left shift input
	RL = "H"	RL = "L"										
PLSR	Right shift input	Left shift output										
PRSL	Right shift output	Left shift input										
RL	I	Shift direction selection signal input	Input signal that selects the shift direction. High: Right shift (Y1 to Y384) Low: Left shift (Y384 to Y1)									
FY	I	Clock input	Data acquisition clock input pin.									
A	I	Analog output control	Controls the analog voltage output.									
POL	I	Output polarity reversal control input	Switches the reference voltage for odd and even outputs.									
INV1 INV2	I	Data inversion control input	Controls inversion of the input image signal. INV1: Used for D2(7 : 0), D1(7 : 0), D0(7 : 0) INV2: Used for D5(7 : 0), D4(7 : 0), D3(7 : 0)									
VREF0 to 9	I	γ correction voltage input	Inputs the γ correction voltage used by the D/A converter.									
VOPU, VOPL	I	Analog reference voltage	Provides the reference voltage that determines the analog circuit operating point. VOPU: Reference voltage for the high side output VOPL : Reference voltage for the low side output									
AVDD AVSS	I	Analog system power supply	Provides the power for the analog circuits.									
DVDD DVSS	I	Digital system power supply	Provides the power for the digital circuits.									
TEST	I	Test (Pull-down resistor: 100 k Ω)	Used for device testing. This pin must be left open during normal operation.									

■ Functional Description

- Relationship between the data input and the analog output pins

The input mode used by this IC is a two-pixel mode in which the data for two pixels is input in parallel from the D0(7:0), D1(7:0), D2(7:0), D3(7:0), D4(7:0), and D5(7:0) input ports.

The correspondence between the data input ports and the output pins is as follows.

$$\begin{aligned}
 Y(6n-5) &= D00 \text{ to } D07 & Y(6n-2) &= D30 \text{ to } D37 \\
 Y(6n-4) &= D10 \text{ to } D17 & Y(6n-1) &= D40 \text{ to } D47 \\
 Y(6n-3) &= D20 \text{ to } D27 & Y(6n) &= D50 \text{ to } D57 \quad (n = 1, 2, \dots, 64)
 \end{aligned}$$

Figure 1 shows an example of color data and pin connections when RL is high.

This example shows the case where the pixels are in the order R, B, G starting at the left edge of the LCD panel.

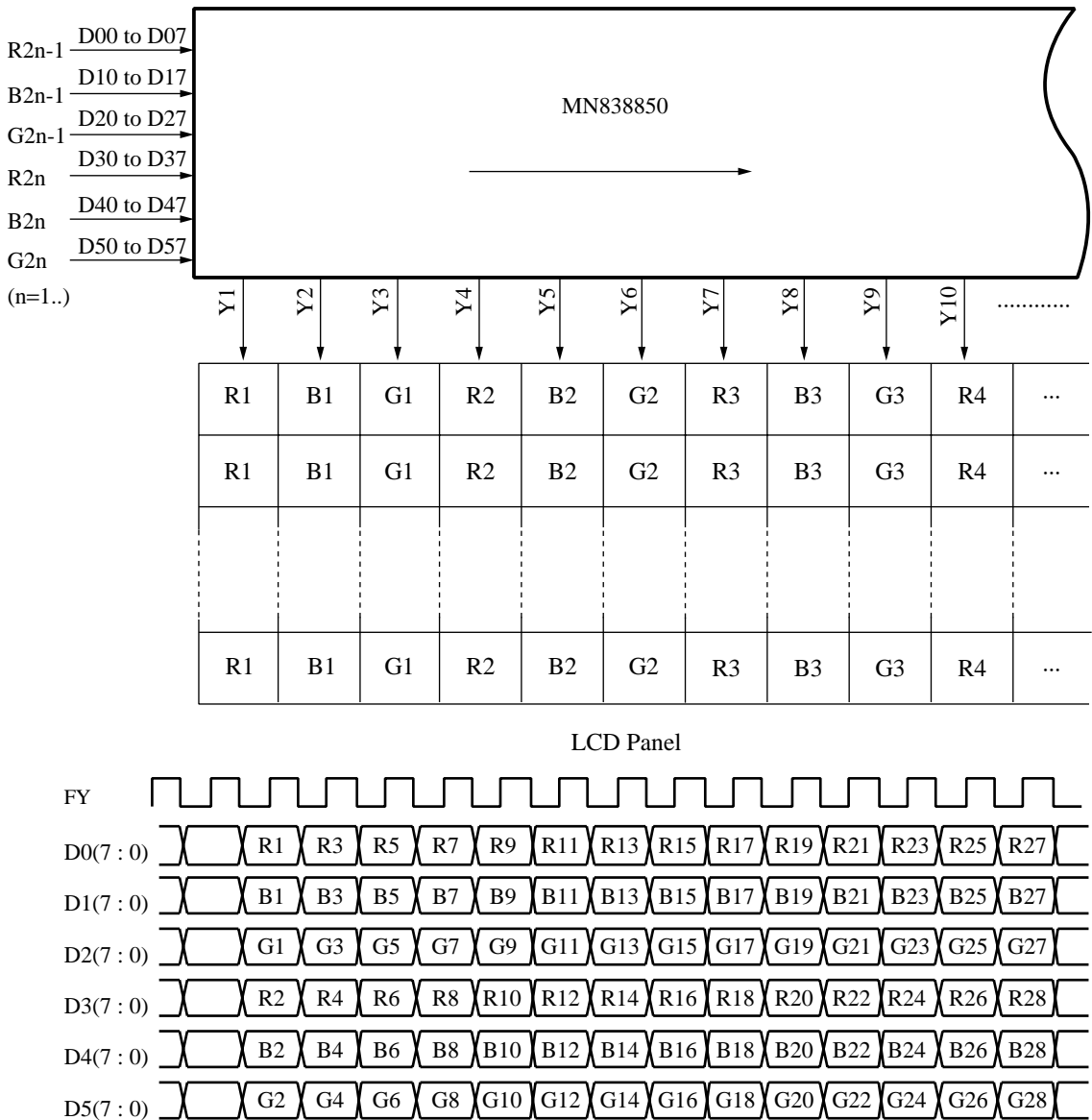

Figure 1 Relationship between Input and Output Pins (When RL is high and the shift direction is Y1 to Y384)

■ Functional Description (continued)

- Relationship between the data input and the analog output pins (continued)

The following presents the case with the same LCD panel color arrangement as figure 1 but with RL low.

In figure 2, R1 corresponds to Y384, B1 to Y383, and G1 to Y382. Note that the relationship between the color data and the data ports here differs from that in figure 1.

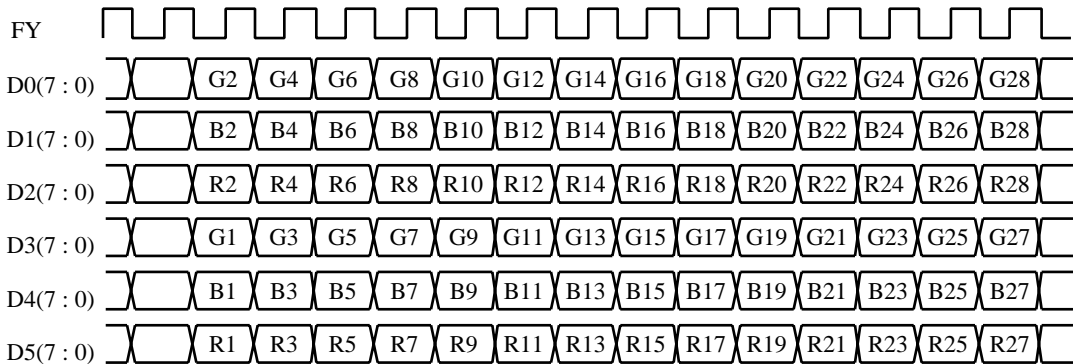
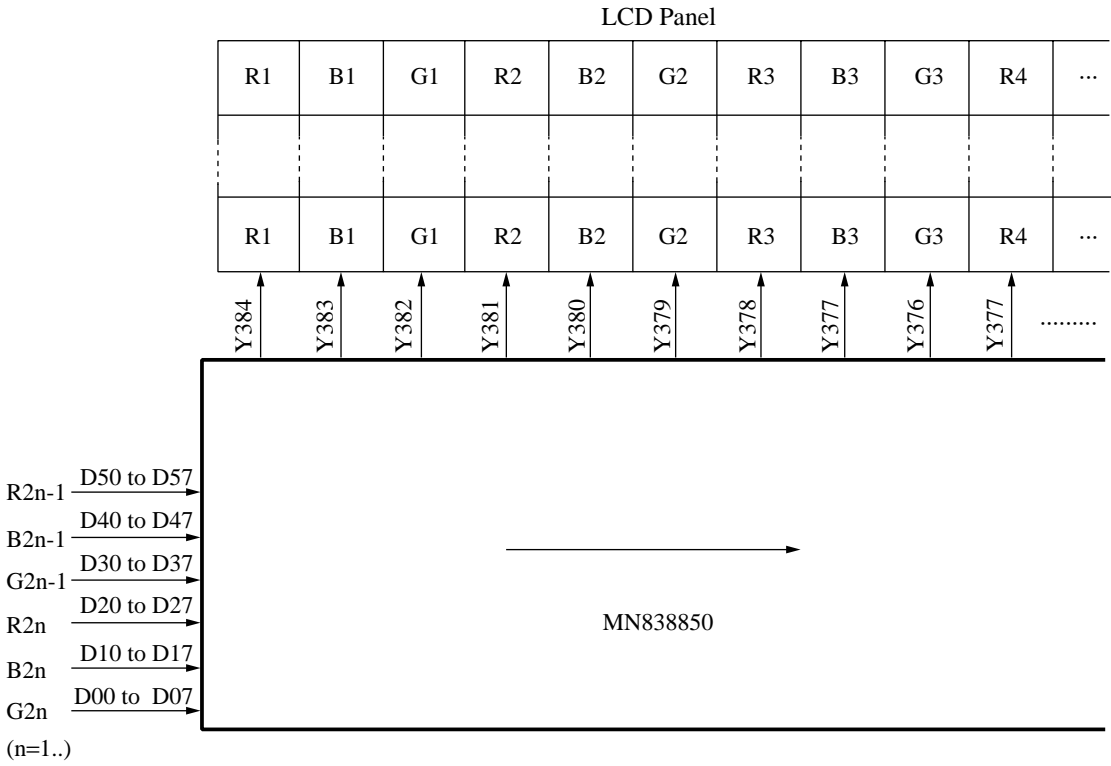

Figure 2 Relationship between Input and Output Pins (When RL is low and the shift direction is Y384 to Y1)

■ Functional Description (continued)

• Dot inversion drive

Since dot inversion drive is used, the analog output voltages with respect to the opposite electrode voltage differ in polarity for each of the odd and even numbered output pins. This output voltage polarity is controlled by POL. The table below lists the correspondence between the POL polarity setting, the analog output polarity and the VREF used.

POL	Y _{2n-1}	Y _{2n}
"L"	Positivepolarity VREF9 to 5	Negativepolarity VREF4 to 0
"H"	Negativepolarity VREF4 to 0	Positivepolarity VREF9 to 5

The POL switching timing is presented below.

POL should be switched during the period when A is low, after the last data has been input, and before the next start signal has been input. The POL signal level is acquired by the device internally on the falling edge of the A signal. The output polarity is determined by the acquired signal level.

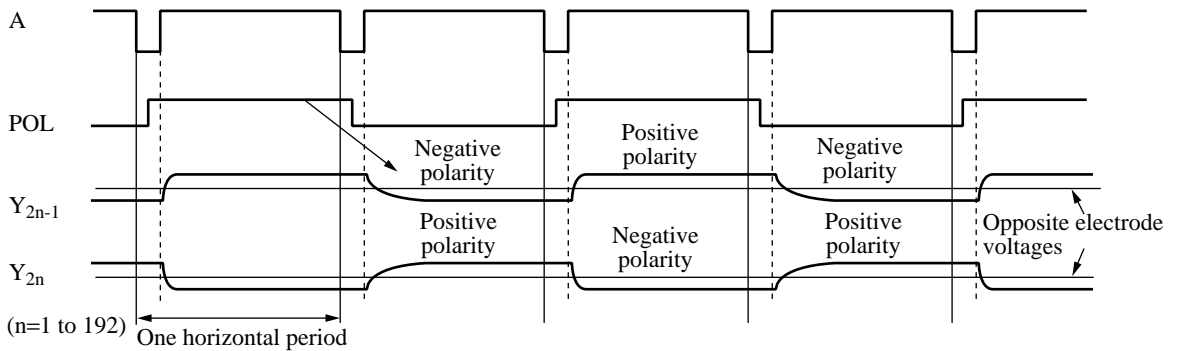

POL Switching Timing

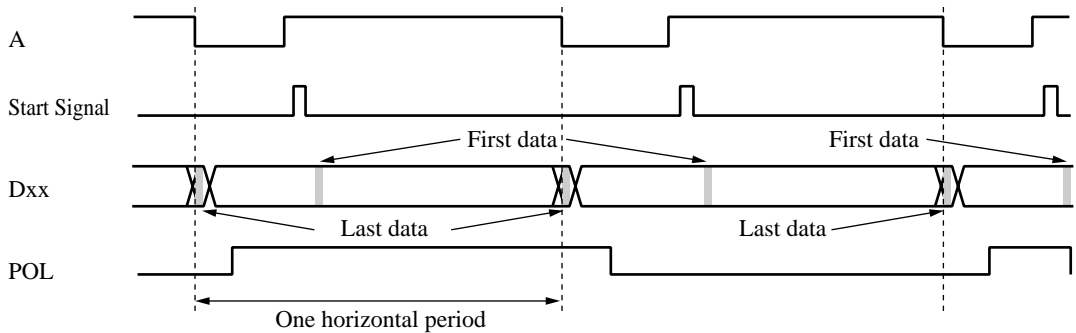

Details of the POL Switching Timing

■ Functional Description (continued)

• Dot inversion drive (continued)

Next we describe dot inversion drive operation.

The symbol "+" here means a voltage that is positive with respect to the voltage on the opposite electrode, and "-" means a voltage that is negative with respect to the voltage on the opposite electrode.

The figure below shows the dot inversion drive operation.

Since POL is low in the first line of the first field, Y1 will be + and Y2 will be -, that is, odd-numbered output pins will have positive polarity and even-numbered output pins will have negative polarity.

Since POL is switched to high for the second line, odd-numbered output pins will have negative polarity and even-numbered output pins will have positive polarity.

Thereafter, the polarity of the output voltages is determined by the POL polarity.

In the second field, the POL polarity will be the opposite of what it was for the first field, so the output voltage polarities will be reversed.

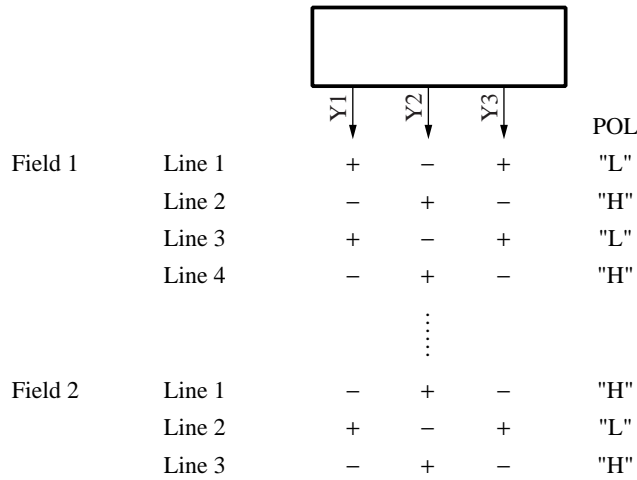

Note that if POL is inverted not every line, but only every field, the output polarities will be as shown below.

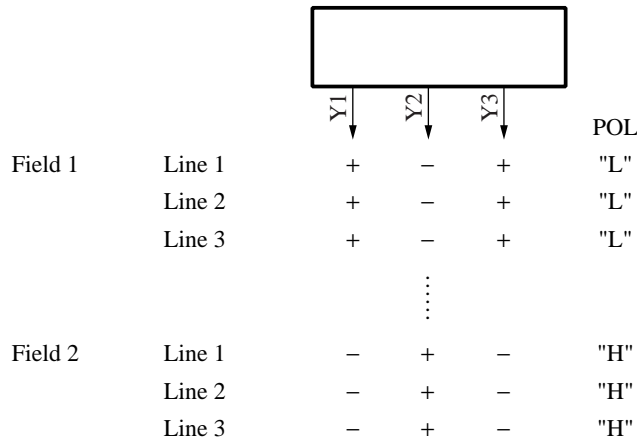

■ Functional Description (continued)

• Operation when Connected in Cascade

When RL is high:

Driver A acquires the PLSR start pulse on the rising edge of FY and starts acquiring data on the next FY rising edge. The PRSL (carry) output will go high 64 clock pulses after the start pulse input and data acquisition will stop one clock cycle later.

Driver B receives the driver A PRSL rising edge and starts accepting data one clock cycle later.

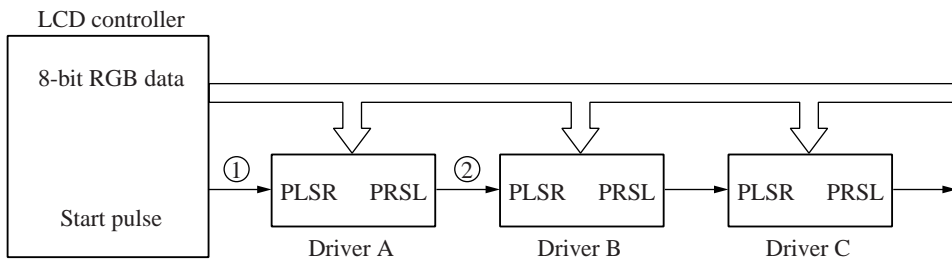
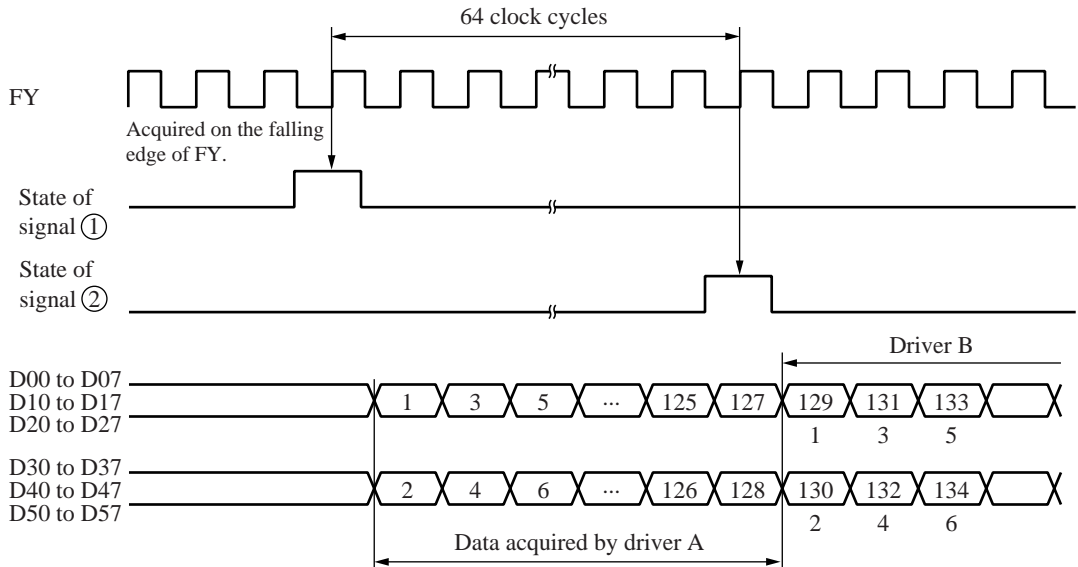

■ Functional Description (continued)

- Relationship between input data values and output voltages

The IC outputs voltages with discrete values and differing polarities for the odd and even output pins with respect to the common electrode. The output voltage is determined by the input data value, the γ correction voltages (VREF0 to VREF9), VOPL, VOPU, and POL.

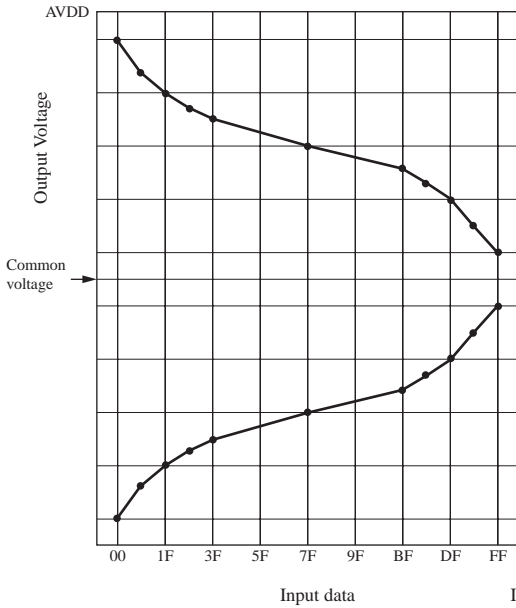

Relationship between Input Data and Output Voltage
 (VREF0 > VREF1 > VREF2 > VREF3 > VREF4,
 VREF5 > VREF6 > VREF7 > VREF8 > VREF9)

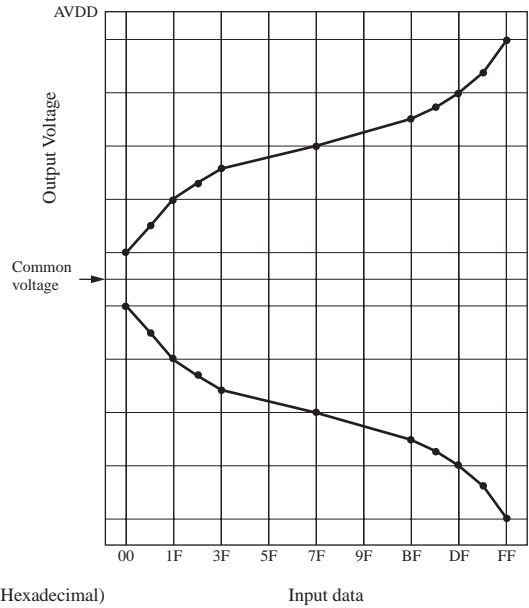

Relationship between Input Data and Output Voltage
 (VREF0 < VREF1 < VREF2 < VREF3 < VREF4,
 VREF5 < VREF6 < VREF7 < VREF8 < VREF9)

■ Functional Description (continued)

- Relationship between input data values and output voltages (continued)

Apply the voltages for the γ correction to the pins VREF0 to VREF9.

The γ correction voltage input pins are divided into two groups: the high-level output control group and the low-level output control group, and each group is connected in series with resistors. Each of these resistor series has a total typical value of 14 k Ω .

This structure is shown in the figure. The typical values of the resistors are shown in parentheses.

Note that since these voltages are resistor divided internally, the voltages applied to the VREF pins should be applied through a low-impedance circuit. If the voltages are directly applied by the resistor divider, the desired output voltages may not result.

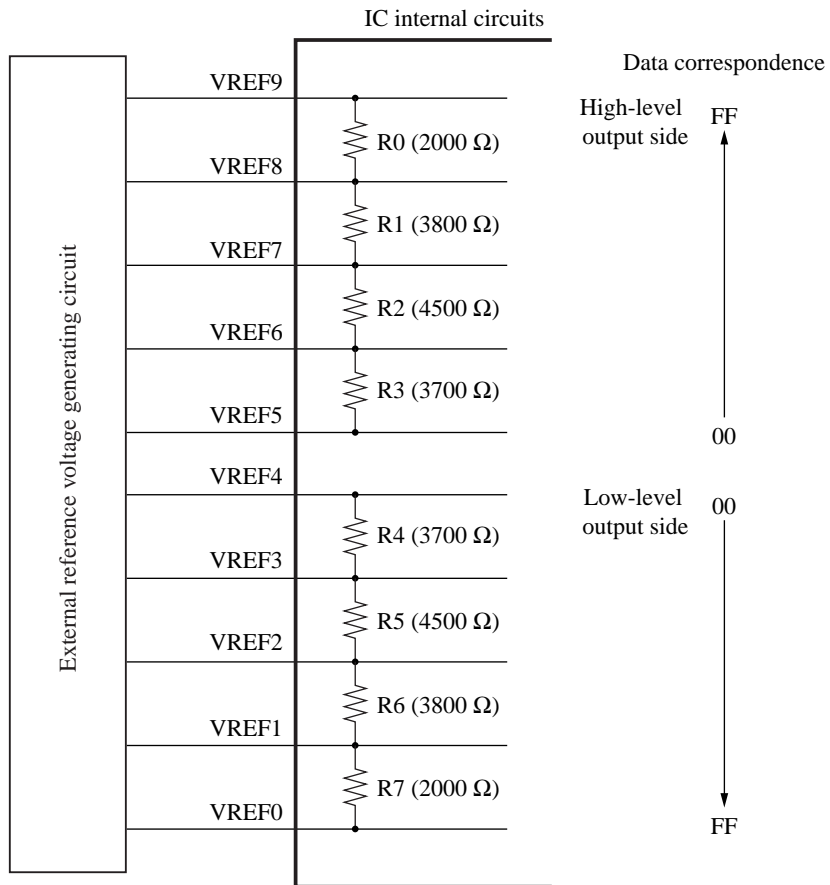

■ Functional Description (continued)

- Table 1 Relationship between VREF Voltages and Analog Output Voltages (High-level side) (Values are examples)
VREF5 = 9.200, VREF6 = 10.635, VREF7 = 12.380, VREF8 = 13.854, VREF9 = 14.630, VOPU = 11.250

Display data	Logical expression	Voltage level	Voltage level difference
00	$VOPU \times 63/31 - (42 \times VREF8 + 1238 \times VREF9) / 1240$	7.787	0.026
01	$VOPU \times 63/31 - (84 \times VREF8 + 1196 \times VREF9) / 1240$	7.813	0.026
02	$VOPU \times 63/31 - (126 \times VREF8 + 1154 \times VREF9) / 1240$	7.839	0.026
⋮			
0D	$VOPU \times 63/31 - (588 \times VREF8 + 692 \times VREF9) / 1240$	8.128	0.026
0E	$VOPU \times 63/31 - (630 \times VREF8 + 650 \times VREF9) / 1240$	8.155	0.026
0F	$VOPU \times 63/31 - (672 \times VREF8 + 608 \times VREF9) / 1240$	8.181	0.023
10	$VOPU \times 63/31 - (710 \times VREF8 + 570 \times VREF9) / 1240$	8.205	0.023
11	$VOPU \times 63/31 - (748 \times VREF8 + 532 \times VREF9) / 1240$	8.228	0.023
12	$VOPU \times 63/31 - (786 \times VREF8 + 494 \times VREF9) / 1240$	8.252	0.023
⋮			
1D	$VOPU \times 63/31 - (1204 \times VREF8 + 76 \times VREF9) / 1240$	8.514	0.023
1E	$VOPU \times 63/31 - (1242 \times VREF8 + 38 \times VREF9) / 1240$	8.537	0.023
1F	$VOPU \times 63/31 - (1280 \times VREF8 + 0 \times VREF9) / 1240$	8.561	0.020
20	$VOPU \times 63/31 - (32 \times VREF7 + 2400 \times VREF8) / 2356$	8.581	0.020
21	$VOPU \times 63/31 - (64 \times VREF7 + 2368 \times VREF8) / 2356$	8.601	0.020
22	$VOPU \times 63/31 - (96 \times VREF7 + 2336 \times VREF8) / 2356$	8.621	0.020
⋮			
2D	$VOPU \times 63/31 - (448 \times VREF7 + 1984 \times VREF8) / 2356$	8.841	0.020
2E	$VOPU \times 63/31 - (480 \times VREF7 + 1952 \times VREF8) / 2356$	8.861	0.020
2F	$VOPU \times 63/31 - (512 \times VREF7 + 1920 \times VREF8) / 2356$	8.882	0.016
30	$VOPU \times 63/31 - (538 \times VREF7 + 1894 \times VREF8) / 2356$	8.898	0.016
31	$VOPU \times 63/31 - (564 \times VREF7 + 1868 \times VREF8) / 2356$	8.914	0.016
32	$VOPU \times 63/31 - (590 \times VREF7 + 1842 \times VREF8) / 2356$	8.930	0.016
⋮			
3D	$VOPU \times 63/31 - (876 \times VREF7 + 1556 \times VREF8) / 2356$	9.109	0.016
3E	$VOPU \times 63/31 - (902 \times VREF7 + 1530 \times VREF8) / 2356$	9.125	0.016
3F	$VOPU \times 63/31 - (928 \times VREF7 + 1504 \times VREF8) / 2356$	9.142	0.015
40	$VOPU \times 63/31 - (953 \times VREF7 + 1479 \times VREF8) / 2356$	9.157	0.015
41	$VOPU \times 63/31 - (978 \times VREF7 + 1454 \times VREF8) / 2356$	9.173	0.015
42	$VOPU \times 63/31 - (1003 \times VREF7 + 1429 \times VREF8) / 2356$	9.189	0.015
⋮			
4D	$VOPU \times 63/31 - (1278 \times VREF7 + 1154 \times VREF8) / 2356$	9.361	0.015
4E	$VOPU \times 63/31 - (1303 \times VREF7 + 1129 \times VREF8) / 2356$	9.376	0.015
4F	$VOPU \times 63/31 - (1328 \times VREF7 + 1104 \times VREF8) / 2356$	9.392	0.015

■ Functional Description (continued)

• Table 1 (continued) Relationship between VREF Voltages and Analog Output Voltages (High-level side) (Values are examples)

VREF5 = 9.200, VREF6 = 10.635, VREF7 = 12.380, VREF8 = 13.854, VREF9 = 14.630, VOPU = 11.250

Display data	Logical expression	Voltage level	Voltage level difference
50	$VOPU \times 63/31 - (1353 \times VREF7 + 1079 \times VREF8) / 2356$	9.408	0.015
51	$VOPU \times 63/31 - (1378 \times VREF7 + 1054 \times VREF8) / 2356$	9.423	0.015
52	$VOPU \times 63/31 - (1403 \times VREF7 + 1029 \times VREF8) / 2356$	9.439	0.015
⋮			
5D	$VOPU \times 63/31 - (1678 \times VREF7 + 754 \times VREF8) / 2356$	9.611	0.015
5E	$VOPU \times 63/31 - (1703 \times VREF7 + 729 \times VREF8) / 2356$	9.627	0.015
5F	$VOPU \times 63/31 - (1728 \times VREF7 + 704 \times VREF8) / 2356$	9.642	0.013
60	$VOPU \times 63/31 - (1750 \times VREF7 + 682 \times VREF8) / 2356$	9.656	0.013
61	$VOPU \times 63/31 - (1772 \times VREF7 + 660 \times VREF8) / 2356$	9.670	0.013
62	$VOPU \times 63/31 - (1794 \times VREF7 + 638 \times VREF8) / 2356$	9.683	0.013
⋮			
6D	$VOPU \times 63/31 - (2036 \times VREF7 + 396 \times VREF8) / 2356$	9.835	0.013
6E	$VOPU \times 63/31 - (2058 \times VREF7 + 374 \times VREF8) / 2356$	9.849	0.013
6F	$VOPU \times 63/31 - (2080 \times VREF7 + 352 \times VREF8) / 2356$	9.862	0.013
70	$VOPU \times 63/31 - (2102 \times VREF7 + 330 \times VREF8) / 2356$	9.876	0.013
71	$VOPU \times 63/31 - (2124 \times VREF7 + 308 \times VREF8) / 2356$	9.890	0.013
72	$VOPU \times 63/31 - (2146 \times VREF7 + 286 \times VREF8) / 2356$	9.904	0.013
⋮			
7D	$VOPU \times 63/31 - (2388 \times VREF7 + 44 \times VREF8) / 2356$	10.055	0.013
7E	$VOPU \times 63/31 - (2410 \times VREF7 + 22 \times VREF8) / 2356$	10.069	0.013
7F	$VOPU \times 63/31 - (2432 \times VREF7 + 0 \times VREF8) / 2356$	10.083	0.013
80	$VOPU \times 63/31 - (11 \times VREF6 + 1429 \times VREF7) / 1395$	10.096	0.013
81	$VOPU \times 63/31 - (22 \times VREF6 + 1418 \times VREF7) / 1395$	10.110	0.013
82	$VOPU \times 63/31 - (33 \times VREF6 + 1407 \times VREF7) / 1395$	10.124	0.013
⋮			
8D	$VOPU \times 63/31 - (154 \times VREF6 + 1286 \times VREF7) / 1395$	10.275	0.013
8E	$VOPU \times 63/31 - (165 \times VREF6 + 1275 \times VREF7) / 1395$	10.289	0.013
8F	$VOPU \times 63/31 - (176 \times VREF6 + 1264 \times VREF7) / 1395$	10.303	0.013
90	$VOPU \times 63/31 - (187 \times VREF6 + 1253 \times VREF7) / 1395$	10.317	0.013
91	$VOPU \times 63/31 - (198 \times VREF6 + 1242 \times VREF7) / 1395$	10.330	0.013
92	$VOPU \times 63/31 - (209 \times VREF6 + 1231 \times VREF7) / 1395$	10.344	0.013
⋮			
9D	$VOPU \times 63/31 - (330 \times VREF6 + 1110 \times VREF7) / 1395$	10.495	0.013
9E	$VOPU \times 63/31 - (341 \times VREF6 + 1099 \times VREF7) / 1395$	10.509	0.013
9F	$VOPU \times 63/31 - (352 \times VREF6 + 1088 \times VREF7) / 1395$	10.523	0.016

■ Functional Description (continued)

- Table 1 (continued) Relationship between VREF Voltages and Analog Output Voltages (High-level side) (Values are examples)
VREF5 = 9.200, VREF6 = 10.635, VREF7 = 12.380, VREF8 = 13.854, VREF9 = 14.630, VOPU = 11.250

Display data	Logical expression	Voltage level	Voltage level difference
A0	$VOPU \times 63/31 - (365 \times VREF6 + 1075 \times VREF7) / 1395$	10.539	0.016
A1	$VOPU \times 63/31 - (378 \times VREF6 + 1062 \times VREF7) / 1395$	10.556	0.016
A2	$VOPU \times 63/31 - (391 \times VREF6 + 1049 \times VREF7) / 1395$	10.572	0.016
⋮			
AD	$VOPU \times 63/31 - (534 \times VREF6 + 906 \times VREF7) / 1395$	10.751	0.016
AE	$VOPU \times 63/31 - (547 \times VREF6 + 893 \times VREF7) / 1395$	10.767	0.016
AF	$VOPU \times 63/31 - (560 \times VREF6 + 880 \times VREF7) / 1395$	10.783	0.016
B0	$VOPU \times 63/31 - (573 \times VREF6 + 867 \times VREF7) / 1395$	10.800	0.016
B1	$VOPU \times 63/31 - (586 \times VREF6 + 854 \times VREF7) / 1395$	10.816	0.016
B2	$VOPU \times 63/31 - (599 \times VREF6 + 841 \times VREF7) / 1395$	10.832	0.016
⋮			
BD	$VOPU \times 63/31 - (742 \times VREF6 + 698 \times VREF7) / 1395$	11.011	0.016
BE	$VOPU \times 63/31 - (755 \times VREF6 + 685 \times VREF7) / 1395$	11.027	0.016
BF	$VOPU \times 63/31 - (768 \times VREF6 + 672 \times VREF7) / 1395$	11.043	0.022
C0	$VOPU \times 63/31 - (786 \times VREF6 + 654 \times VREF7) / 1395$	11.066	0.022
C1	$VOPU \times 63/31 - (804 \times VREF6 + 636 \times VREF7) / 1395$	11.089	0.022
C2	$VOPU \times 63/31 - (822 \times VREF6 + 618 \times VREF7) / 1395$	11.111	0.022
⋮			
CD	$VOPU \times 63/31 - (1020 \times VREF6 + 420 \times VREF7) / 1395$	11.359	0.022
CE	$VOPU \times 63/31 - (1038 \times VREF6 + 402 \times VREF7) / 1395$	11.381	0.022
CF	$VOPU \times 63/31 - (1056 \times VREF6 + 384 \times VREF7) / 1395$	11.404	0.030
D0	$VOPU \times 63/31 - (1080 \times VREF6 + 360 \times VREF7) / 1395$	11.434	0.030
D1	$VOPU \times 63/31 - (1104 \times VREF6 + 336 \times VREF7) / 1395$	11.464	0.030
D2	$VOPU \times 63/31 - (1128 \times VREF6 + 312 \times VREF7) / 1395$	11.494	0.030
⋮			
DD	$VOPU \times 63/31 - (1392 \times VREF6 + 48 \times VREF7) / 1395$	11.824	0.030
DE	$VOPU \times 63/31 - (1416 \times VREF6 + 24 \times VREF7) / 1395$	11.854	0.030
DF	$VOPU \times 63/31 - (1440 \times VREF6 + 0 \times VREF7) / 1395$	11.884	0.041
E0	$VOPU \times 63/31 - (66 \times VREF5 + 2302 \times VREF6) / 2294$	11.926	0.041
E1	$VOPU \times 63/31 - (132 \times VREF5 + 2236 \times VREF6) / 2294$	11.967	0.041
E2	$VOPU \times 63/31 - (198 \times VREF5 + 2170 \times VREF6) / 2294$	12.008	0.041
⋮			
ED	$VOPU \times 63/31 - (924 \times VREF5 + 1444 \times VREF6) / 2294$	12.462	0.041
EE	$VOPU \times 63/31 - (990 \times VREF5 + 1378 \times VREF6) / 2294$	12.504	0.041
EF	$VOPU \times 63/31 - (1056 \times VREF5 + 1312 \times VREF6) / 2294$	12.545	0.051

■ Functional Description (continued)

- Table 1 (continued) Relationship between VREF Voltages and Analog Output Voltages (High-level side) (Values are examples)

VREF5 = 9.200, VREF6 = 10.635, VREF7 = 12.380, VREF8 = 13.854, VREF9 = 14.630, VOPU = 11.250

Display data	Logical expression	Voltage level	Voltage level difference
F0	$VOPU \times 63/31 - (1138 \times VREF5 + 1230 \times VREF6) / 2294$	12.596	0.051
F1	$VOPU \times 63/31 - (1220 \times VREF5 + 1148 \times VREF6) / 2294$	12.647	0.051
F2	$VOPU \times 63/31 - (1302 \times VREF5 + 1066 \times VREF6) / 2294$	12.699	0.051
⋮			
FD	$VOPU \times 63/31 - (2204 \times VREF5 + 164 \times VREF6) / 2294$	13.263	0.051
FE	$VOPU \times 63/31 - (2286 \times VREF5 + 82 \times VREF6) / 2294$	13.314	0.051
FF	$VOPU \times 63/31 - (2368 \times VREF5 + 0 \times VREF6) / 2294$	13.366	

- Table 2 Relationship between VREF Voltages and Analog Output Voltages (Low-level side) (Values are examples)

VREF0 = 1.760, VREF1 = 2.536, VREF2 = 4.010, VREF3 = 5.755, VREF4 = 7.190, VOPL = 3.750

Display data	Logical expression	Voltage level	Voltage level difference
00	$VOPL \times 63/31 - (42 \times VREF1 + 1238 \times VREF0) / 1240$	5.777	0.026
01	$VOPL \times 63/31 - (84 \times VREF1 + 1196 \times VREF0) / 1240$	5.751	0.026
02	$VOPL \times 63/31 - (126 \times VREF1 + 1154 \times VREF0) / 1240$	5.725	0.026
⋮			
0D	$VOPL \times 63/31 - (588 \times VREF1 + 692 \times VREF0) / 1240$	5.436	0.026
0E	$VOPL \times 63/31 - (630 \times VREF1 + 650 \times VREF0) / 1240$	5.410	0.026
0F	$VOPL \times 63/31 - (672 \times VREF1 + 608 \times VREF0) / 1240$	5.383	0.023
10	$VOPL \times 63/31 - (710 \times VREF1 + 570 \times VREF0) / 1240$	5.360	0.023
11	$VOPL \times 63/31 - (748 \times VREF1 + 532 \times VREF0) / 1240$	5.336	0.023
12	$VOPL \times 63/31 - (786 \times VREF1 + 494 \times VREF0) / 1240$	5.312	0.023
⋮			
1D	$VOPL \times 63/31 - (1204 \times VREF1 + 76 \times VREF0) / 1240$	5.051	0.023
1E	$VOPL \times 63/31 - (1242 \times VREF1 + 38 \times VREF0) / 1240$	5.027	0.023
1F	$VOPL \times 63/31 - (1280 \times VREF1 + 0 \times VREF0) / 1240$	5.003	0.020
20	$VOPL \times 63/31 - (32 \times VREF2 + 2400 \times VREF1) / 2356$	4.983	0.020
21	$VOPL \times 63/31 - (64 \times VREF2 + 2368 \times VREF1) / 2356$	4.963	0.020
22	$VOPL \times 63/31 - (96 \times VREF2 + 2336 \times VREF1) / 2356$	4.943	0.020
⋮			
2D	$VOPL \times 63/31 - (448 \times VREF2 + 1984 \times VREF1) / 2356$	4.723	0.020
2E	$VOPL \times 63/31 - (480 \times VREF2 + 1952 \times VREF1) / 2356$	4.703	0.020
2F	$VOPL \times 63/31 - (512 \times VREF2 + 1920 \times VREF1) / 2356$	4.683	0.016

■ Functional Description (continued)

• Table 2 (continued) Relationship between VREF Voltages and Analog Output Voltages (Low-level side) (Values are examples)

VREF0 = 1.760, VREF1 = 2.536, VREF2 = 4.010, VREF3 = 5.755, VREF4 = 7.190, VOPL = 3.750

Display data	Logical expression	Voltage level	Voltage level difference
30	$VOPL \times 63/31 - (538 \times VREF2 + 1894 \times VREF1) / 2356$	4.666	0.016
31	$VOPL \times 63/31 - (564 \times VREF2 + 1868 \times VREF1) / 2356$	4.650	0.016
32	$VOPL \times 63/31 - (590 \times VREF2 + 1842 \times VREF1) / 2356$	4.634	0.016
⋮			
3D	$VOPL \times 63/31 - (876 \times VREF2 + 1556 \times VREF1) / 2356$	4.455	0.016
3E	$VOPL \times 63/31 - (902 \times VREF2 + 1530 \times VREF1) / 2356$	4.439	0.016
3F	$VOPL \times 63/31 - (928 \times VREF2 + 1504 \times VREF1) / 2356$	4.422	0.015
40	$VOPL \times 63/31 - (953 \times VREF2 + 1479 \times VREF1) / 2356$	4.407	0.015
41	$VOPL \times 63/31 - (978 \times VREF2 + 1454 \times VREF1) / 2356$	4.391	0.015
42	$VOPL \times 63/31 - (1003 \times VREF2 + 1429 \times VREF1) / 2356$	4.376	0.015
⋮			
4D	$VOPL \times 63/31 - (1278 \times VREF2 + 1154 \times VREF1) / 2356$	4.203	0.015
4E	$VOPL \times 63/31 - (1303 \times VREF2 + 1129 \times VREF1) / 2356$	4.188	0.015
4F	$VOPL \times 63/31 - (1328 \times VREF2 + 1104 \times VREF1) / 2356$	4.172	0.015
50	$VOPL \times 63/31 - (1353 \times VREF2 + 1079 \times VREF1) / 2356$	4.157	0.015
51	$VOPL \times 63/31 - (1378 \times VREF2 + 1054 \times VREF1) / 2356$	4.141	0.015
52	$VOPL \times 63/31 - (1403 \times VREF2 + 1029 \times VREF1) / 2356$	4.125	0.015
⋮			
5D	$VOPL \times 63/31 - (1678 \times VREF2 + 754 \times VREF1) / 2356$	3.953	0.015
5E	$VOPL \times 63/31 - (1703 \times VREF2 + 729 \times VREF1) / 2356$	3.938	0.015
5F	$VOPL \times 63/31 - (1728 \times VREF2 + 704 \times VREF1) / 2356$	3.922	0.013
60	$VOPL \times 63/31 - (1750 \times VREF2 + 682 \times VREF1) / 2356$	3.908	0.013
61	$VOPL \times 63/31 - (1772 \times VREF2 + 660 \times VREF1) / 2356$	3.894	0.013
62	$VOPL \times 63/31 - (1794 \times VREF2 + 638 \times VREF1) / 2356$	3.881	0.013
⋮			
6D	$VOPL \times 63/31 - (2036 \times VREF2 + 396 \times VREF1) / 2356$	3.729	0.013
6E	$VOPL \times 63/31 - (2058 \times VREF2 + 374 \times VREF1) / 2356$	3.716	0.013
6F	$VOPL \times 63/31 - (2080 \times VREF2 + 352 \times VREF1) / 2356$	3.702	0.013
70	$VOPL \times 63/31 - (2102 \times VREF2 + 330 \times VREF1) / 2356$	3.688	0.013
71	$VOPL \times 63/31 - (2124 \times VREF2 + 308 \times VREF1) / 2356$	3.674	0.013
72	$VOPL \times 63/31 - (2146 \times VREF2 + 286 \times VREF1) / 2356$	3.660	0.013
⋮			
7D	$VOPL \times 63/31 - (2388 \times VREF2 + 44 \times VREF1) / 2356$	3.509	0.013
7E	$VOPL \times 63/31 - (2410 \times VREF2 + 22 \times VREF1) / 2356$	3.495	0.013
7F	$VOPL \times 63/31 - (2432 \times VREF2 + 0 \times VREF1) / 2356$	3.482	0.013

■ Functional Description (continued)

• Table 2 (continued) Relationship between VREF Voltages and Analog Output Voltages (Low-level side) (Values are examples)

VREF0 = 1.760, VREF1 = 2.536, VREF2 = 4.010, VREF3 = 5.755, VREF4 = 7.190, VOPL = 3.750

Display data	Logical expression	Voltage level	Voltage level difference
80	$VOPL \times 63/31 - (11 \times VREF3 + 1429 \times VREF2) / 1395$	3.468	0.013
81	$VOPL \times 63/31 - (22 \times VREF3 + 1418 \times VREF2) / 1395$	3.454	0.013
82	$VOPL \times 63/31 - (33 \times VREF3 + 1407 \times VREF2) / 1395$	3.440	0.013
⋮			
8D	$VOPL \times 63/31 - (154 \times VREF3 + 1286 \times VREF2) / 1395$	3.289	0.013
8E	$VOPL \times 63/31 - (165 \times VREF3 + 1275 \times VREF2) / 1395$	3.275	0.013
8F	$VOPL \times 63/31 - (176 \times VREF3 + 1264 \times VREF2) / 1395$	3.261	0.013
90	$VOPL \times 63/31 - (187 \times VREF3 + 1253 \times VREF2) / 1395$	3.248	0.013
91	$VOPL \times 63/31 - (198 \times VREF3 + 1242 \times VREF2) / 1395$	3.234	0.013
92	$VOPL \times 63/31 - (209 \times VREF3 + 1231 \times VREF2) / 1395$	3.220	0.013
⋮			
9D	$VOPL \times 63/31 - (330 \times VREF3 + 1110 \times VREF2) / 1395$	3.069	0.013
9E	$VOPL \times 63/31 - (341 \times VREF3 + 1099 \times VREF2) / 1395$	3.055	0.013
9F	$VOPL \times 63/31 - (352 \times VREF3 + 1088 \times VREF2) / 1395$	3.041	0.016
A0	$VOPL \times 63/31 - (365 \times VREF3 + 1075 \times VREF2) / 1395$	3.025	0.016
A1	$VOPL \times 63/31 - (378 \times VREF3 + 1062 \times VREF2) / 1395$	3.009	0.016
A2	$VOPL \times 63/31 - (391 \times VREF3 + 1049 \times VREF2) / 1395$	2.992	0.016
⋮			
AD	$VOPL \times 63/31 - (534 \times VREF3 + 906 \times VREF2) / 1395$	2.813	0.016
AE	$VOPL \times 63/31 - (547 \times VREF3 + 893 \times VREF2) / 1395$	2.797	0.016
AF	$VOPL \times 63/31 - (560 \times VREF3 + 880 \times VREF2) / 1395$	2.781	0.016
B0	$VOPL \times 63/31 - (573 \times VREF3 + 867 \times VREF2) / 1395$	2.765	0.016
B1	$VOPL \times 63/31 - (586 \times VREF3 + 854 \times VREF2) / 1395$	2.748	0.016
B2	$VOPL \times 63/31 - (599 \times VREF3 + 841 \times VREF2) / 1395$	2.732	0.016
⋮			
BD	$VOPL \times 63/31 - (742 \times VREF3 + 698 \times VREF2) / 1395$	2.553	0.016
BE	$VOPL \times 63/31 - (755 \times VREF3 + 685 \times VREF2) / 1395$	2.537	0.016
BF	$VOPL \times 63/31 - (768 \times VREF3 + 672 \times VREF2) / 1395$	2.521	0.022
C0	$VOPL \times 63/31 - (786 \times VREF3 + 654 \times VREF2) / 1395$	2.498	0.022
C1	$VOPL \times 63/31 - (804 \times VREF3 + 636 \times VREF2) / 1395$	2.476	0.022
C2	$VOPL \times 63/31 - (822 \times VREF3 + 618 \times VREF2) / 1395$	2.453	0.022
⋮			
CD	$VOPL \times 63/31 - (1020 \times VREF3 + 420 \times VREF2) / 1395$	2.205	0.022
CE	$VOPL \times 63/31 - (1038 \times VREF3 + 402 \times VREF2) / 1395$	2.183	0.022
CF	$VOPL \times 63/31 - (1056 \times VREF3 + 384 \times VREF2) / 1395$	2.160	0.030

■ Functional Description (continued)

- Table 2 (continued) Relationship between VREF Voltages and Analog Output Voltages (Low-level side) (Values are examples)

VREF0 = 1.760, VREF1 = 2.536, VREF2 = 4.010, VREF3 = 5.755, VREF4 = 7.190, VOPL = 3.750

Display data	Logical expression	Voltage level	Voltage level difference
D0	$VOPL \times 63/31 - (1080 \times VREF3 + 360 \times VREF2) / 1395$	2.130	0.030
D1	$VOPL \times 63/31 - (1104 \times VREF3 + 336 \times VREF2) / 1395$	2.100	0.030
D2	$VOPL \times 63/31 - (1128 \times VREF3 + 312 \times VREF2) / 1395$	2.070	0.030
⋮			
DD	$VOPL \times 63/31 - (1392 \times VREF3 + 48 \times VREF2) / 1395$	1.740	0.030
DE	$VOPL \times 63/31 - (1416 \times VREF3 + 24 \times VREF2) / 1395$	1.710	0.030
DF	$VOPL \times 63/31 - (1440 \times VREF3 + 0 \times VREF2) / 1395$	1.680	0.041
E0	$VOPL \times 63/31 - (66 \times VREF4 + 2302 \times VREF3) / 2294$	1.639	0.041
E1	$VOPL \times 63/31 - (132 \times VREF4 + 2236 \times VREF3) / 2294$	1.597	0.041
E2	$VOPL \times 63/31 - (198 \times VREF4 + 2170 \times VREF3) / 2294$	1.556	0.041
⋮			
ED	$VOPL \times 63/31 - (924 \times VREF4 + 1444 \times VREF3) / 2294$	1.102	0.041
EE	$VOPL \times 63/31 - (990 \times VREF4 + 1378 \times VREF3) / 2294$	1.061	0.041
EF	$VOPL \times 63/31 - (1056 \times VREF4 + 1312 \times VREF3) / 2294$	1.019	0.051
F0	$VOPL \times 63/31 - (1138 \times VREF4 + 1230 \times VREF3) / 2294$	0.968	0.051
F1	$VOPL \times 63/31 - (1220 \times VREF4 + 1148 \times VREF3) / 2294$	0.917	0.051
F2	$VOPL \times 63/31 - (1302 \times VREF4 + 1066 \times VREF3) / 2294$	0.865	0.051
⋮			
FD	$VOPL \times 63/31 - (2204 \times VREF4 + 164 \times VREF3) / 2294$	0.301	0.051
FE	$VOPL \times 63/31 - (2286 \times VREF4 + 82 \times VREF3) / 2294$	0.250	0.051
FF	$VOPL \times 63/31 - (2368 \times VREF4 + 0 \times VREF3) / 2294$	0.199	

■ Functional Description (continued)

- Relationship between the A signal, the image input timing, and the start pulse

The figure below shows the relationship between the A signal, the image data input timing, and the start pulse.

The last data of the image should be input within one clock cycle of the fall of the A signal. Data input two or more clock cycles later will not be transmitted to the analog outputs and the IC will not be able to output the correct analog voltage. And also hold the levels of the data bus fixed from 1 μ s before the rise of the A signal until 4 clock cycles after the rise of the A signal. The output analog voltages may be displaced or shifted if the data bus levels are changed with that timing.

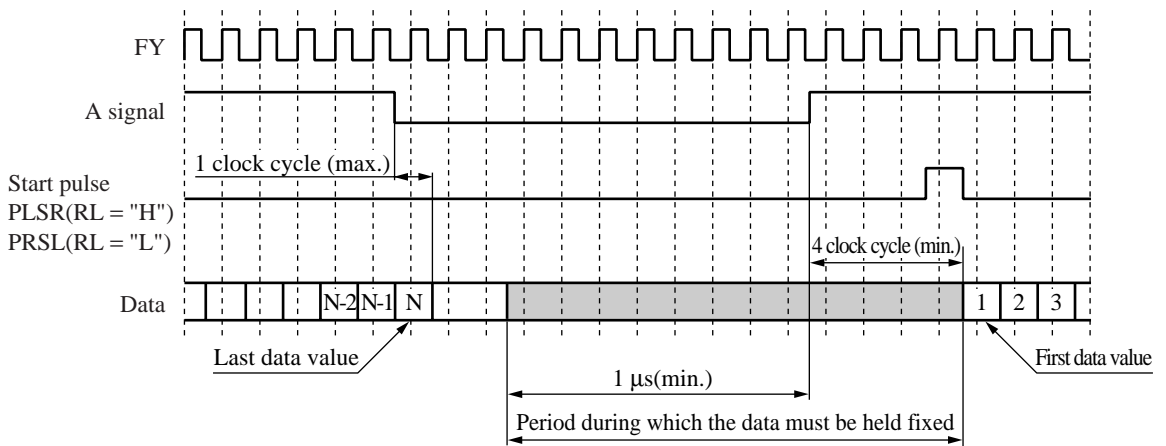

■ Functional Description (continued)

• Data inversion control function

All the bits in the input image data can be inverted at the same time, thus creating new data values to be used by controlling the INV1 and INV2 pins.

INV1 inverts the D0(7:0), D1(7:0), and D2(7:0) data and INV2 inverts the D3(7:0), D4(7:0), and D5(7:0) data.

The figure below shows the inversion control provided by INV1 and INV2 for the input image data.

The input image data and the INV1 and INV2 states are acquired on the same clock cycle, and the data is controlled by the INV1 and INV2 logic states at that time.

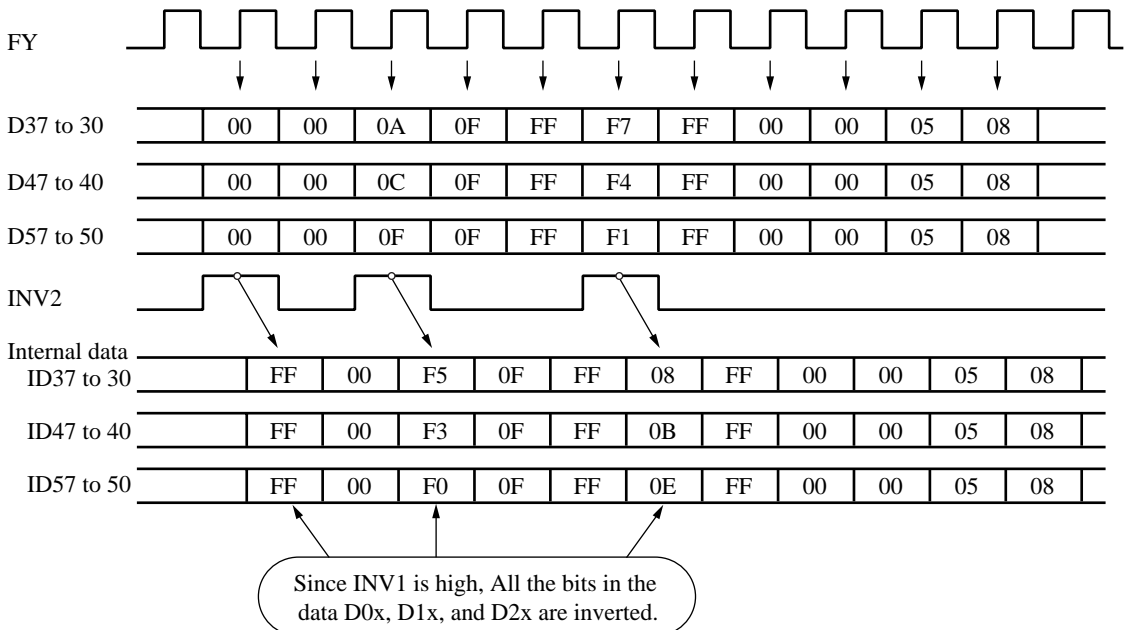
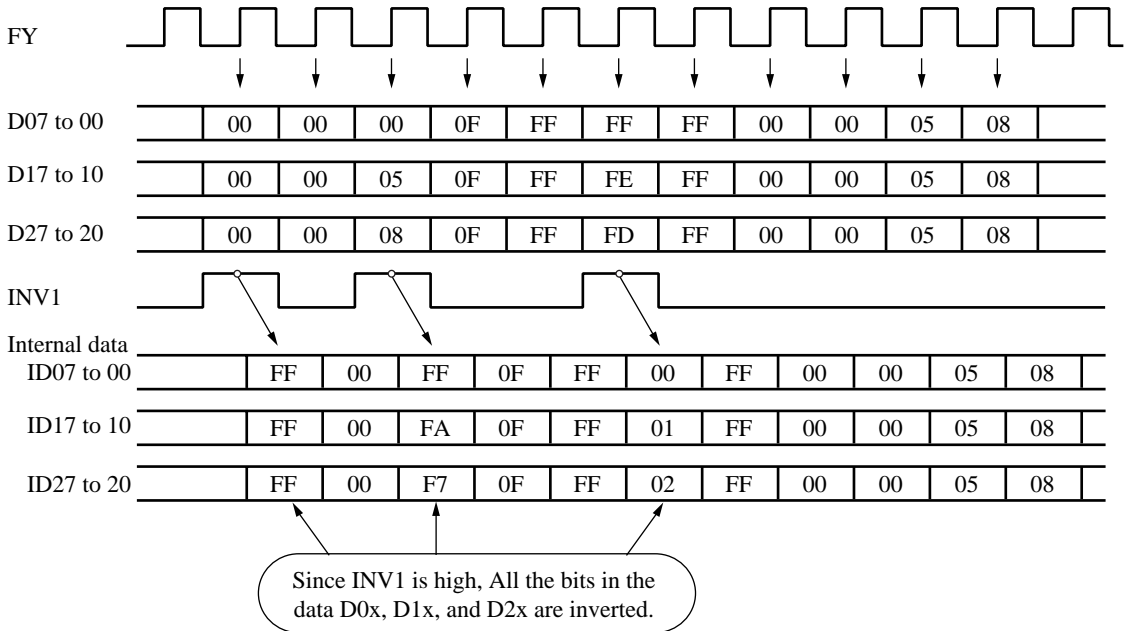

■ Functional Description (continued)

- Possible periods of the clock stop

The possible periods of the clock stop in which clock has been stopped are shown below.

The clock signal must be provided during the period starting one clock cycle before the start pulse input and ending 5 clock cycles after the rise of the A signal.

However, if it is not the case that the first data is input with the next clock timing (T) after the input of the start pulse, the clock may be stopped during the period between the start pulse input and the start of data input. The clock signal may be stopped at either the high or low level.

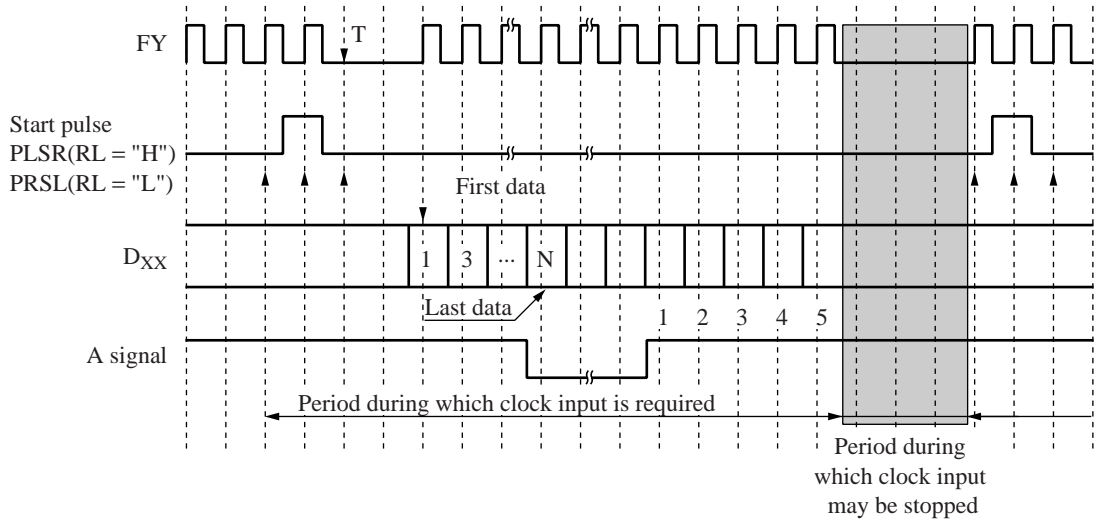

■ Electrical Characteristics

1. Absolute Maximum Ratings at A_{VSS} = 0 V, D_{VSS} = 0 V

Parameter	Symbol	Rating	Unit
Digital system supply voltage	D _{VDD}	- 0.3 to +7.0	V
Analog system supply voltage	A _{VDD}	- 0.3 to +17	V
Digital input voltage	V _{I1}	- 0.3 to D _{VDD} +0.3	V
Analog input voltage	V _{I2}	- 0.3 to A _{VDD} +0.3	V
Digital output voltage	V _{O1}	- 0.3 to D _{VDD} +0.3	V
Analog output voltage	V _{O2}	- 0.3 to A _{VDD} +0.3	V
Operating temperature	T _{opr}	-20 to +75	°C
Storage temperature	T _{stg}	-40 to +110	°C

Note) The absolute maximum ratings are limiting values under which the device will not be destroyed. Operation is not guaranteed within these ranges.

■ Electrical Characteristics (continued)

2. Operating Conditions at $A_{VSS} = D_{VSS} = 0\text{ V}$, $T_a = -20\text{ °C}$ to $+75\text{ °C}$

Parameter	Symbol	Conditions	Min	Typ	Max	Unit
Operating digital system supply voltage	D_{VDD}	$f_{FY\text{ max}} = 50\text{ MHz}$	3.1	—	3.6	V
		$f_{FY\text{ max}} = 40\text{ MHz}$	2.7	—	3.6	
Operating analog system supply voltage	A_{VDD}		14.5	—	15.5	V
γ correction voltage input voltage range	V_{REF0} to 4		0.2	—	$A_{VDD}/2$	V
	V_{REF5} to 9		$A_{VDD}/2$	—	$A_{VDD}-0.2$	
Operating frequency		$D_{VDD} = 3.1\text{ V}$ to 3.6 V	—	—	50	MHz
		$D_{VDD} = 2.7\text{ V}$ to 3.6 V	—	—	40	
Digital signal input capacitance	C_{IN}	At 1 MHz	—	5	—	pF
γ correction voltage input capacitance	C_{VREF}	At 1 MHz	—	500	—	pF
VOPL input voltage range			$A_{VDD}/4 - 0.2$	—	$A_{VDD}/4 + 0.2$	V
VOPU input voltage range			$A_{VDD} \times 3/4 - 0.2$	—	$A_{VDD} \times 3/4 + 0.2$	V
VREF resistance VREF9 to 5, VREF4 to 0	R_{VREF}		—	14	—	k Ω

Note) 1. All the A_{VDD} power supply pins must be connected to each other directly.

2. All the A_{VSS} and D_{VSS} power supply pins must be connected to each other directly.

3. When first applying power, first apply the D_{VDD} voltage, then apply the logic input pin signal levels, and then apply the A_{VDD} voltage. After that apply the VOP and VREF reference voltages. When cutting the power, remove these voltages in the reverse order.

3. DC Characteristics at $D_{VDD} = 2.7\text{ V}$ to 3.6 V , $A_{VDD} = 14.5\text{ V}$ to 15.5 V , $A_{VSS} = D_{VSS} = 0\text{ V}$, $T_a = -20\text{ °C}$ to $+75\text{ °C}$

Parameter	Symbol	Conditions	Min	Typ	Max	Unit
Operating analog supply current 1 *1,3	I_{SS1}		—	39	45	mA
Operating analog supply current 2	I_{SS2}	$A_{VDD} = 15\text{ V}$ *1,3 With no load	—	11	—	mA
Operating digital supply current *1,2	I_{SS3}		—	2	8	mA
Digital quiescent supply current	I_{SS4}	In the clock stopped state	—	—	100	μA

1) Input pins RL, A, D00 to D07, D10 to D17, D20 to D27, D30 to D37, D40 to D47, D50 to D57, FY, POL, INV1, INV2

High-level input voltage	V_{IH1}		$0.7 \times D_{VDD}$	—	D_{VDD}	V
Low-level input voltage	V_{IL1}		0	—	$0.3 \times D_{VDD}$	V
Input leakage current	I_{LI1}		-10	—	10	μA

2) I/O pins PRSL, PLSR

High-level input voltage	V_{IH2}		$0.7 \times D_{VDD}$	—	D_{VDD}	V
Low-level input voltage	V_{IL2}		0	—	$0.3 \times D_{VDD}$	V
High-level output voltage	V_{OH}	$D_{VDD} = 3.3\text{ V}$, $I_O = -5\text{ mA}$	$0.7 \times D_{VDD}$	—	—	V
Low-level output voltage	V_{OL}	$D_{VDD} = 3.3\text{ V}$, $I_O = 2\text{ mA}$	—	—	$0.3 \times D_{VDD}$	V
Input leakage current	I_{LI2}		-10	—	10	μA

■ Electrical Characteristics (continued)

3. DC Characteristics at $D_{VDD} = 2.7\text{ V to }3.6\text{ V}$, $A_{VDD} = 14.5\text{ V to }15.5\text{ V}$, $A_{VSS} = D_{VSS} = 0\text{ V}$, $T_a = -20\text{ }^\circ\text{C to }+75\text{ }^\circ\text{C}$ (continued)

Parameter	Symbol	Conditions	Min	Typ	Max	Unit
3) Pull-down resistor pin TEST						
High-level input voltage	V_{IH3}		$0.7 \times D_{VDD}$	—	D_{VDD}	V
Low-level input voltage	V_{IL3}		0	—	$0.3 \times D_{VDD}$	V
Input leakage current	I_{LI3}		-10	—	10	μA
Pull-down resistance	R_{PD}		40	100	350	k Ω

4) Reference voltage input pins VOPU, VOPL

Input current	I_{VOP}		-100	—	100	μA
---------------	-----------	--	------	---	-----	---------------

5) Analog output pins Y1 to Y384

Output current ^{*4}	I_{VOH}	$V_X = 15\text{ V}$, $V_{OUT} = 14\text{ V}$, $A_{VDD} = 15\text{ V}$, $D_{VDD} = 3.3\text{ V}$	—	-0.5	-0.2	mA
	I_{VOL}	$V_X = 0.0\text{ V}$, $V_{OUT} = 1.0\text{ V}$, $A_{VDD} = 15\text{ V}$, $D_{VDD} = 3.3\text{ V}$	0.2	0.5	—	
Output voltage difference ^{*5}	ΔV_O	$A_{VDD} = 15\text{ V}$, $D_{VDD} = 3.3\text{ V}$	—	± 4	± 20	mV

6) Analog output pin (Y1 to Y384) output voltage range

Operating voltage range ^{*6}	V_O		$A_{VSS} + 0.2$	—	$A_{VDD} - 0.2$	V
---------------------------------------	-------	--	-----------------	---	-----------------	---

Note) 1. ^{*1}: The standard conditions are as follows. A clock frequency of 50 MHz, a raster period of 15 μs , the data pattern fixed at FF, the POL level switched between high and low at each raster period, INV1 and INV2 held fixed at the low level, and each of VREF0 to VREF9 held fixed at its respective levels.

^{*2}: The maximum conditions are as follows. A clock frequency of 50 MHz, a raster period of 15 μs , the data pattern switches between FF and 00 on each clock cycle, the POL level switched between high and low at each raster period, INV1 and INV2 held fixed at the low level, and each of VREF0 to VREF9 held fixed at its respective levels.

^{*3}: The loads on the analog output pins (Y1 to Y384) are shown below. The values of the components in the load circuit are subject to change.

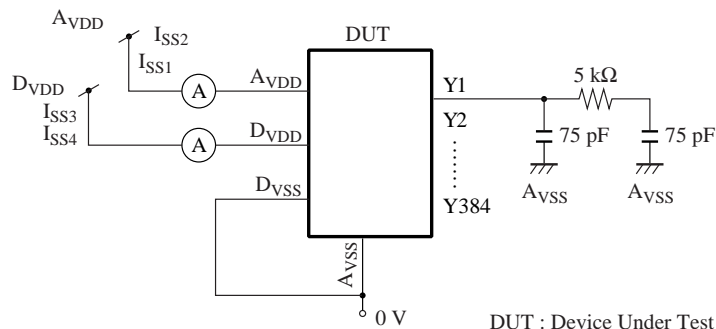

^{*4}: The V_X are the output voltages from the analog output pins Y1 to Y384.

The V_{OUT} are the voltages applied to the analog output pins Y1 to Y384.

^{*5}: The standard conditions apply when the output voltages are at the same voltage as VOPL and VOPU.

^{*6}: Set up VREF0 to VREF9, VOPU, and VOPL so that the output voltages never exceed the output voltage range listed above.

2. The following formula expresses the power dissipation when the loads described in ^{*3} above are attached.

$$I_{SS1} \times A_{VDD} + I_{SS3} \times D_{VDD}$$

Replace ISS1 in the above formula with the value of ISS2 to calculate the power dissipation when there is no load.

3. The supply current in the no load state is provided for reference purposes and is not guaranteed.

■ Electrical Characteristics (continued)

4. AC Characteristics at $D_{VDD} = 2.7\text{ V to }3.6\text{ V}$, $A_{VDD} = 14.5\text{ V to }15.5\text{ V}$, $A_{VSS} = D_{VSS} = 0\text{ V}$, $T_a = -20\text{ }^\circ\text{C to }+75\text{ }^\circ\text{C}$ (continued)

Parameter	Symbol	Conditions	Min	Typ	Max	Unit
FY period	t_p	$D_{VDD} = 3.1\text{ V to }3.6\text{ V}$	20	—	—	ns
		$D_{VDD} = 2.7\text{ V to }3.6\text{ V}$	25	—	—	
Clock high-level period	$t_{w\text{cH}}$		4	—	—	ns
Clock low-level period	$t_{w\text{cL}}$		4	—	—	ns
Data and INV setup time	t_{st1}		0	—	—	ns
Data and INV hold time	t_{hd1}		4	—	—	ns
Start pulse setup time	t_{st2}		0	—	—	ns
Start pulse hold time	t_{hd2}		4	—	—	ns
Start pulse low-level period	t_{wsL}		2	—	—	Clock cycles
Start pulse high-level period	t_{wsH}		1	—	—	Clock cycles
Carry signal delay time	t_{d1}	$CL = 15\text{ pF}$, $D_{VDD} = 3.1\text{ V to }3.6\text{ V}$	—	—	13	ns
		$CL = 15\text{ pF}$, $D_{VDD} = 2.7\text{ V to }3.6\text{ V}$	—	—	17	
Carry signal rise time	t_c		64			Clock cycles
A signal low-level period	t_{wA}		2	—	—	μs
A signal start pulse setup time *1	t_{st3}		4	—	—	Clock cycles
Data input invalid time *1	t_{ng1}		1			Clock cycles
Last data timing *1	t_{ng2}		—	—	1	Clock cycles
LCD drive signal delay time *2,3	t_{d2}	$A_{VDD} = 15\text{ V}$	—	—	11	μs

Note) *1: The starting point is at the rise of the first clock cycle after the rise of the PRSL (PLSR) signal.

*2: Stipulated as the value until the drive output voltage reaches the target output voltage $\pm 20\text{ mV}$ (not including the deviation).

*3: See note 1. *3 in section 3. DC Characteristics for the analog output pin load.

■ Electrical Characteristics (continued)

4. AC Characteristics (continued)

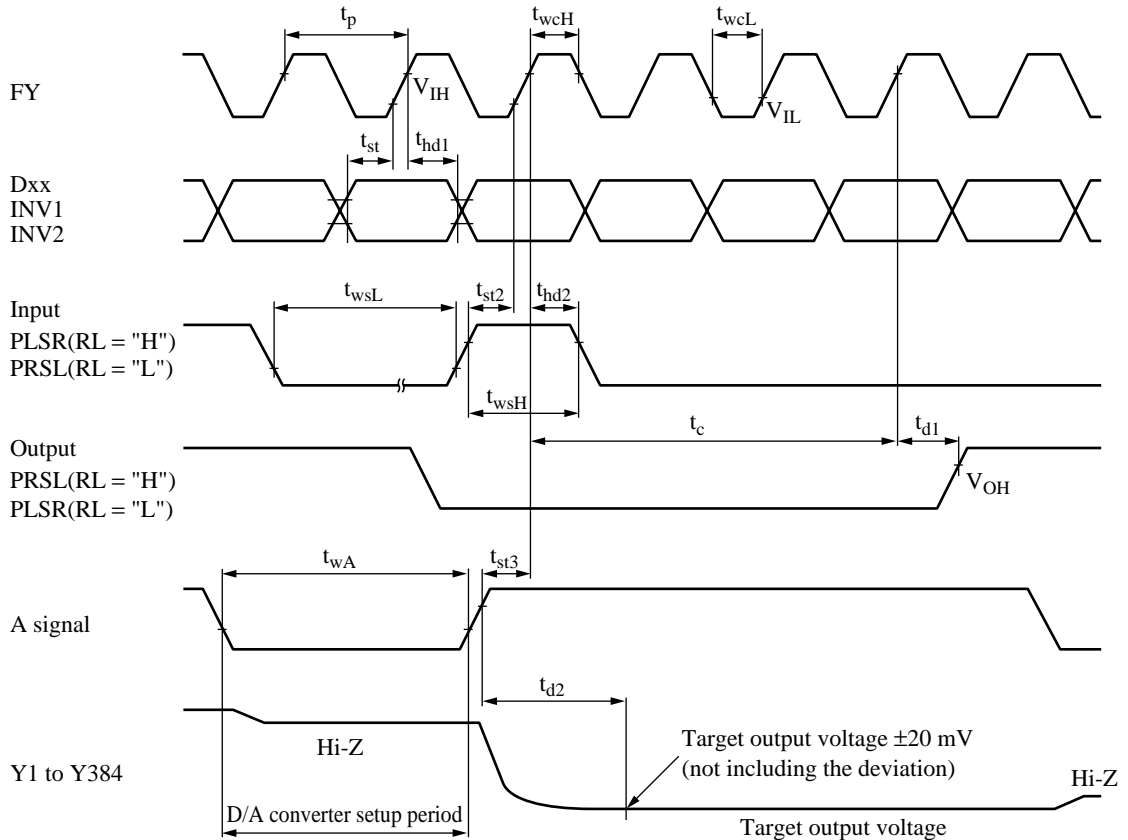

The D/A converter setup period (when the outputs are high impedance) is synchronized with the falling edge of the A signal.

Unless otherwise specified, the digital input and output levels are

$$V_{IH} = V_{OH} \cdot 0.7 \times D_{VDD}, V_{IL} = V_{OL} = 0.3 \times D_{VDD}$$

■ Electrical Characteristics (continued)

4. AC Characteristics (continued)

