

MN63154

EEPROM for IC Cards

■ Overview

The MN63154 is an EEPROM for use in IC cards. It features security features and an address specification system using opcode input.

Low cost combined with high security makes the chips ideal for use in prepaid cards and other types of IC cards.

■ Features

- Easy-to-use control system
 - Address specification system using opcode input over a 3-wire interface (CLK, I/O, and RST)
 - Automatic erasing and writing using a single 5 volt power supply

- Flexible memory-layout

The memory is divided into 11 areas. Six areas containing 500 bytes are freely usable.

- Advanced security features

- Verification of IC card authenticity

The IC passes entered data through a random number generator circuit on its way to output to provide a check of card validity.

- Protection against malicious experimentation

Four or more unsuccessful attempts to access the IC card render it permanently unusable.

- Protection of individual memory areas on the card

Read or write access to a memory area requires matches for both security and condition codes. There is also a condition code for permanently disabling re-write.

- Mixed configuration of EPROM and EEPROM

Individual areas consist of EPROM or EEPROM.

- High reliability

- Write cycles: 10,000 times
- Data storage interval: 10 years

■ Applications

- IC cards

■ Pad Assignment

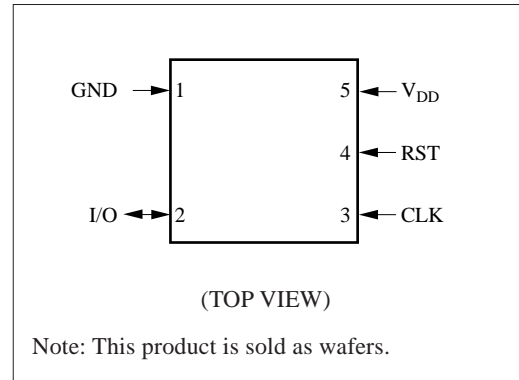

■ Block Diagram

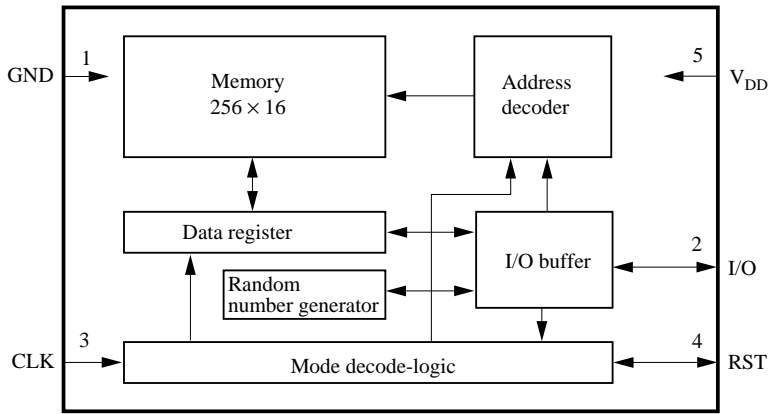

■ Pin Descriptions

Pin No.	Symbol	Pin Name	I/O
1	GND	Ground	I
2	I/O	Data I/O	I/O
3	CLK	Clock	I
4	RST	Reset	I
5	V _{DD}	Power supply	I

■ Electrical Characteristics

V_{CC}=4.5 to 5.5V, T_a=-10°C to +70°C

Parameter	Symbol	Test Conditions	min	max	Unit
Power supply voltage	V _{CC}		4.5	5.5	V
"L" level input leakage current	I _{LIL}		-10	10	μA
"H" level input leakage current	I _{LIH}		-10	10	μA
V _{CC} power supply current (during operation)	I _{CC}	V _{CC} =5.5V CLK=800kHz	—	5.45	mA
V _{CC} power supply current (during standby)	I _{SB}	CLK="L" I/O="H"	—	0.18	mA

Notes

1: I/O pins use N-channel, open drain configuration.

2: Input voltages, output voltages, and other items not listed above conform to ISO/IEC 7816-3.

■ Function Descriptions

Orders	Start bit	Operation code	Address	Data	Contents
READ	0	10	A ₈ , A ₇ to A ₀	D ₀ , D ₁ to D ₃₁	Read
WRITE	0	01	A ₈ , A ₇ to A ₀	D ₀ , D ₁ to D ₁₅	Write
VERIFY	0	11	000001010	D ₀ , D ₁ to D ₃₁	Verify code
RNGEN	0	00	000001010	D ₀ , D ₁ to D ₃₁ D ₀₀ , D ₀₁ to D ₀₃₁	Verify code, generate random number
RESET	0	11	111111111	—	Reset
EWEN	0	00	1xxxxxxx	—	Enable write

Note: x means "don't care".

■ Memory Layout

Area	Contents	Number of Bits	Memory Type
A	Chip manufacturer's code	16	EPROM
B	Card manufacturer's code	16	EPROM
C	Spare area 1	32	EPROM
D	Spare area 2	16	EEPROM
E	Spare area 3	48	EPROM
F	Spare area 4	16	EEPROM
G	Security code	32	EEPROM
H	Error counter	16	EEPROM
I1	Condition code 1	8	EPROM
I2	Condition code 2	8	EEPROM
J	Application area 1	1952	EEPROM
K	Application area 2	1936	EEPROM

■ Timing Chart

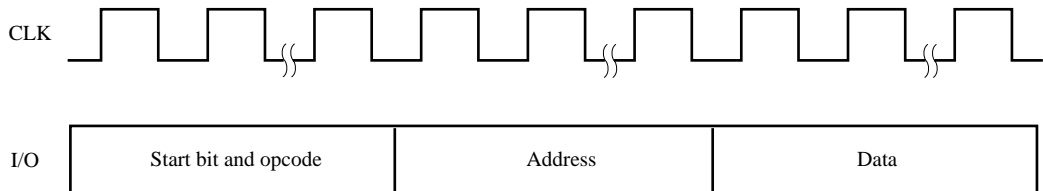

Note: This product is sold as wafers.