

DN8522S-A

Prescaler IC for CATV

■ Overview

The DN8522S-A is 1.7 GHz prescaler IC for CATV. It is made up of ECL flip-flop circuit which can be switched to the dividing ratios of 64, 128 or 256.

■ Features

- Power dissipation: 5 V, 26 mA
- To be switched to the dividing ratios of 64, 128 and 256
- ECL-level output

■ Applications

- Television, VCR

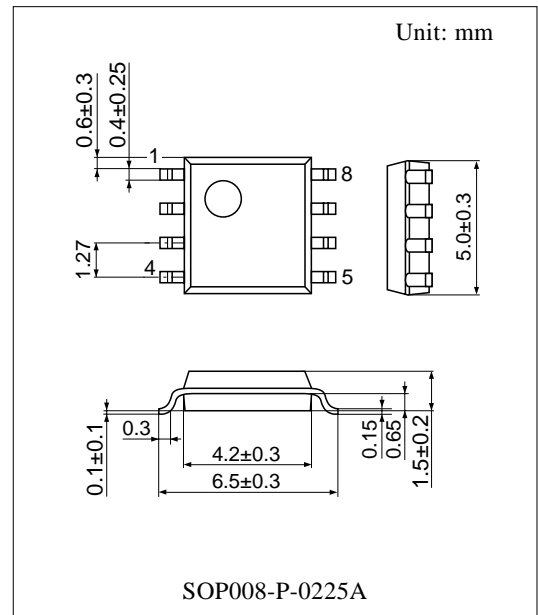

■ Block Diagram

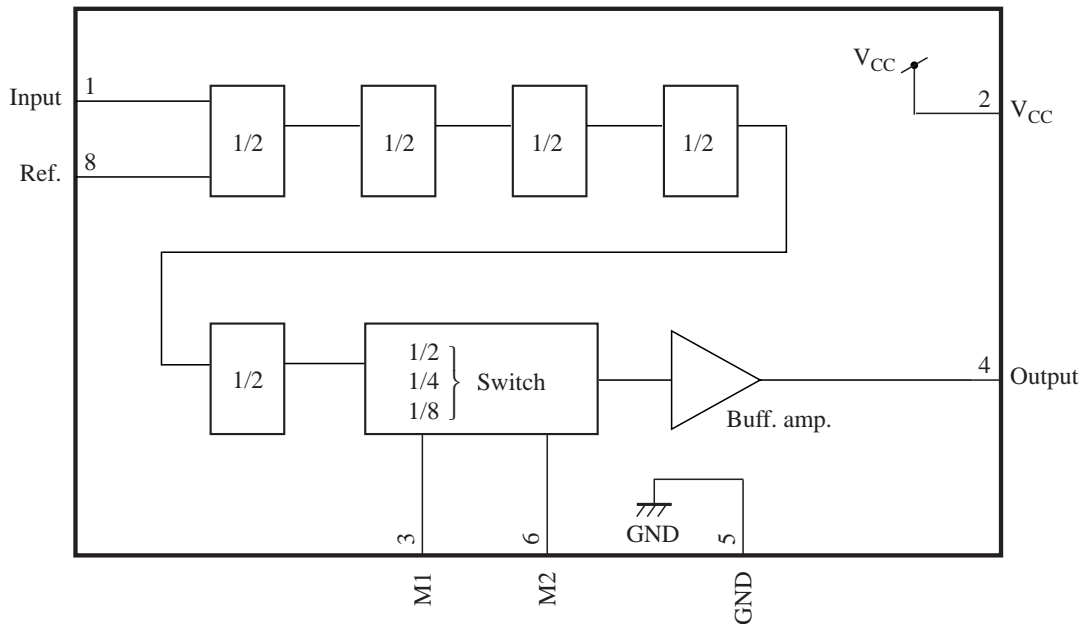

■ Pin Descriptions

Pin No.	Description
1	Input pin
2	Supply voltage pin
3	Dividing ratio select pin: M1
4	Output pin
5	GND pin
6	Dividing ratio select pin: M2
7	N.C.
8	Bias (Ref.) pin

■ Absolute Maximum Ratings

Parameter	Symbol	Rating	Unit
Supply voltage	V_{CC}	6.0	V
Supply current	I_{CC}	40	mA
Power dissipation *2	P_D	160	mW
Operating ambient temperature *1	T_{opr}	-20 to +80	°C
Storage temperature *1	T_{stg}	-55 to +125	°C

Note) 1. *1: Except for the operating ambient temperature and storage temperature, all ratings are for $T_a = 25^\circ\text{C}$.

*2: The power dissipation shown is for the IC package at $T_a = 80^\circ\text{C}$

■ Recommended Operating Range

Parameter	Symbol	Range	Unit
Supply voltage	V_{CC}	4.5 to 5.5	V

■ Electrical Characteristics at $T_a = 25^\circ\text{C}$

Parameter	Symbol	Conditions	Min	Typ	Max	Unit
Supply voltage	V_{CC}		4.5	5.0	5.5	V
Supply current	I_{CC}	$V_{CC} = 5\text{ V}$	—	26	36	mA
Input frequency	f_{IN}	$V_{CC} = 5.0\text{ V}$, $V_{IN} = -15\text{ dBm}$	0.6	—	1.7	GHz
Input signal level	V_{IN1}	$V_{CC} = 5.0\text{ V}$, $T_a = -20^\circ\text{C}$ to 80°C $f_{IN} = 0.6\text{ GHz}$ to 1.7 GHz	-15	—	+3	dBm
Output amplitude	V_O	$V_{CC} = 5\text{ V}$, $f_{IN} = 1.7\text{ GHz}$ $V_{IN} = -10\text{ dBm}$, divided by 64	0.6	1.0	1.6	V[p-p]
High-level input voltage	V_{IH}	Dividing ratio select voltage pin 3, pin 6	$0.7 \times V_{CC}$	—	—	V
Low-level input voltage	V_{IL}	Dividing ratio select voltage pin 3, pin 6	—	—	$0.2 \times V_{CC}$	V

■ Application Circuit Example

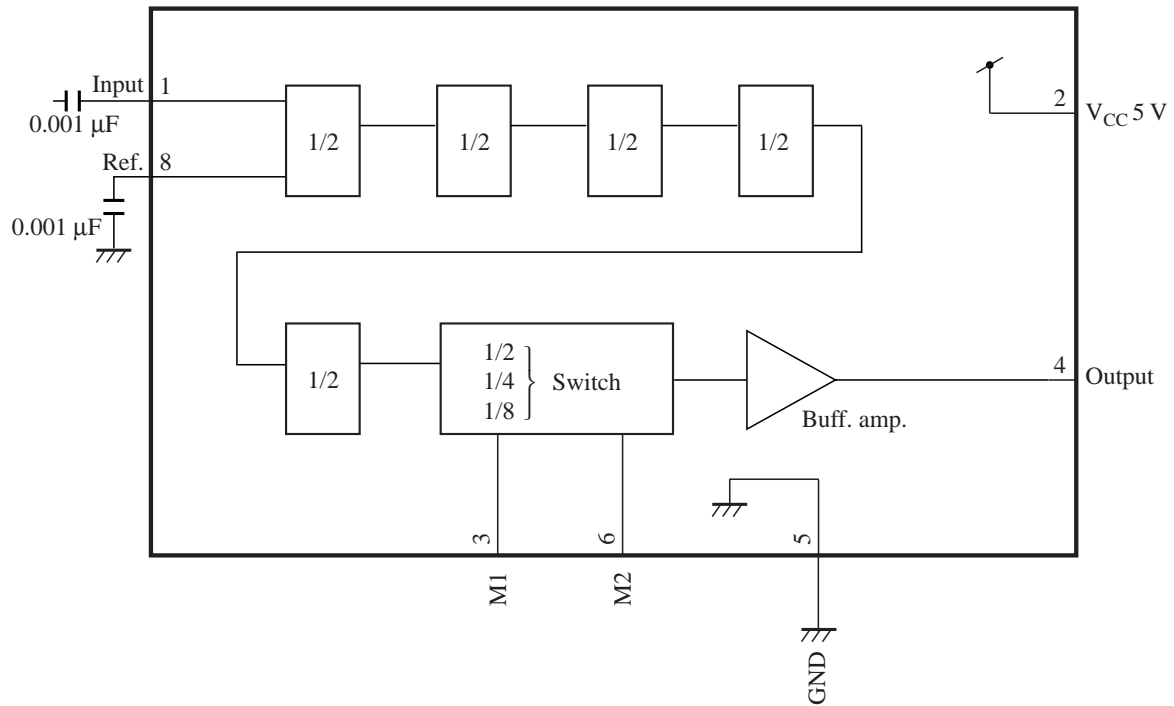

Dividing ratio select pin: M1/M2 settings and related dividing ratios are as follows: High = V_{CC} , Low = GND

Pin 3 M1	Pin 6 M2	Dividing ratio
Low	Low	1/256
Low	High	1/128
High	Low	
High	High	1/64