

AN6701S

Temperature Sensor IC

■ Overview

The AN6701S is an integrated circuit designed for temperature sensing. Since a temperature characteristic adjusting circuit and buffer amp. in addition to temperature sensor circuit are integrated, the temperature sensing operation with high sensitivity as well as high precision can easily be done by a single external resistor.

■ Features

- High sensitivity (100mV/°C)
- Excellent linearity (non linearity.±0.5%)
- Easy calibration with an external resistor
- High precision (±1°C) with calibration

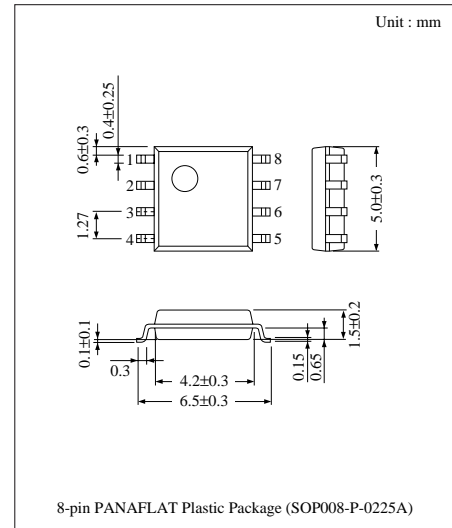

■ Pin Descriptions

Pin No.	Pin name
1	V _{CC}
2	Output voltage
3	GND
4	R _c
5	NC
6	NC
7	NC
8	NC

■ Block Diagram

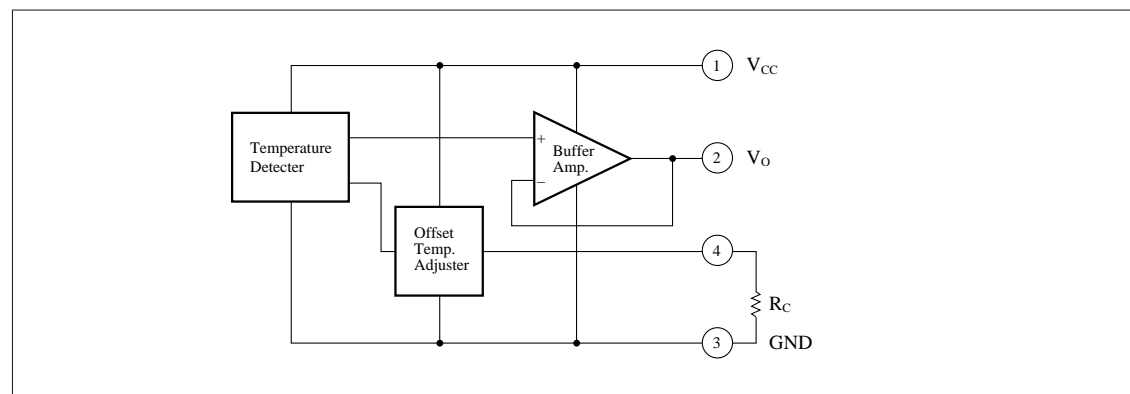

■ Absolute Maximum Ratings (Ta=25°C)

Parameter	Symbol	Rating	Unit
Supply voltage	V _{CC}	16	V
Supply current	I _{CC}	4	mA
Power dissipation	P _D	70	mW
Operating ambient temperature	T _{opr}	-10 to +80	°C
Storage temperature	T _{stg}	-55 to +125	°C

■ Typical Characteristics

Parameter	Value	Unit
Applicable temperature	-10 to +80	°C
Sensitivity (R _C =1 to 100kΩ)	104 to 112	mV/°C
Non-linearity	±0.5	%
Offset temperature (R _C =1 to 100kΩ)	-30 to -10	°C
Thermal constant τ (during quiescent airing)	24	s
Thermal constant τ (during spray airing)	11	s
Thermal resistance (during quiescent airing)	300	°C/W

Note) Offset temperature is a temperature in which output becomes “0” when input/output characteristics are inserted externally.

■ Electrical Characteristics (Ta=-10°C — +80°C)

Parameter	Symbol	Condition	min	typ	max	Unit
Supply voltage	V _{CC}	R _C =10kΩ, R _L =∞	5	9	15	V
Supply current	I _{CC}	V _{CC} =15V, R _C =10kΩ, R _L =∞, Ta=25°C	0.2	0.4	0.8	mA
Output voltage	V _O	Not calibrated ¹⁾ , V _{CC} =15V, Ta=0°C	1.3	2.3	3.3	V
		Not calibrated ¹⁾ , V _{CC} =15V, Ta=25°C	4	5	6	V
		Not calibrated ¹⁾ , V _{CC} =15V, Ta=80°C	10	11	12	V
		Calibrated ²⁾ , V _{CC} =15V, Ta=-10°C	1.1	1.2	1.4	V
		Calibrated ²⁾ , V _{CC} =15V, Ta=60°C	8.6	8.8	9	V
		Calibrated ²⁾ , V _{CC} =15V, Ta=80°C	10.8	11	11.2	V
Supply voltage fluctuate due to output change	DV _{OV}	R _C =10kΩ, Ta=0°C, V _{CC} =5 to 15V	—	0.15	0.22	V
Non-linearity	NL	Not calibrated ¹⁾ , V _{CC} =15V, Ta=0 to 80°C	—	±0.5	±2	%
Output current	I _O	R _C =10kΩ, V _{CC} =9V, Ta=25°C, DV _O =±50mV	100	—	—	μA
Output resistance	R _O		—	30	200	Ω

Note1) R_C=10kΩ

Note2) Adjust R_C value to be V_O=5.0V when Ta=25°C

■ Characteristics Curve

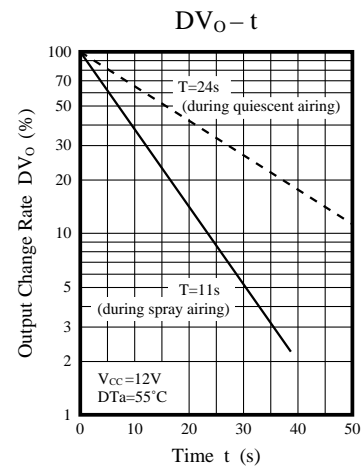
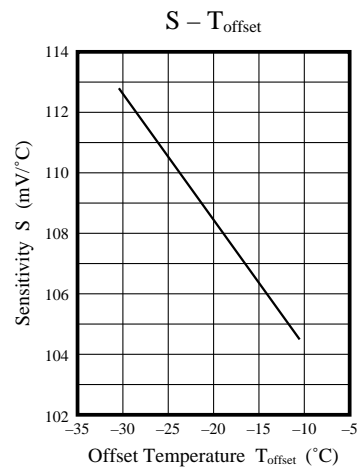
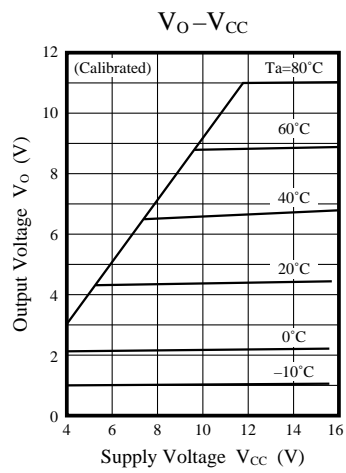
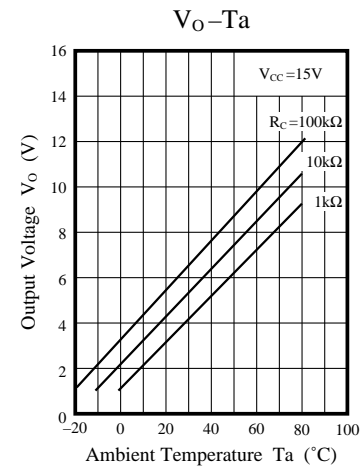
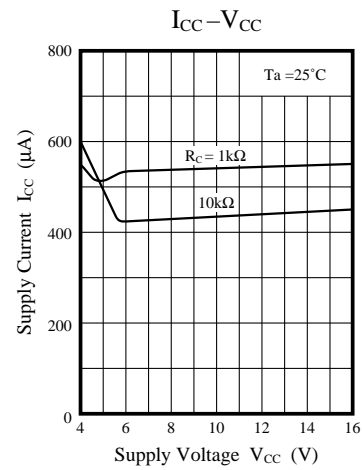
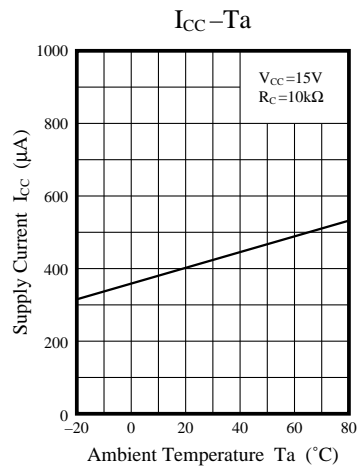

■ Application Circuit

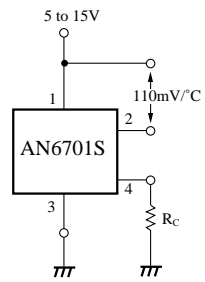

(a) When positive power supply is used.

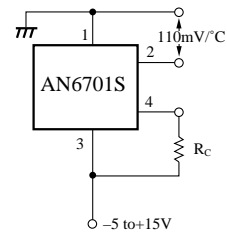

(b) When negative power supply is used.

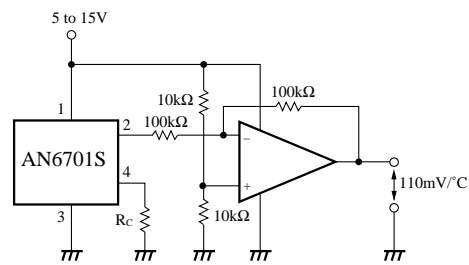

(c) When output polarity is inverted.