

# MIP506

## Silicon MOS IC

### ■ Features

- 3-pin intelligent power device
- Five protective functions (over-current, over-voltage, short circuit load, over heat, ESD) are integrated
- Acceptable both AC and DC power supply

### ■ Applications

- For lamp and solenoid drive

### ■ Absolute Maximum Ratings (Ta = 25°C)

Parameter	Symbol	Rated	Unit
Drain to Source voltage	$V_{DS}$	45	V
Output peak current	$I_{OP}$	$\pm 7.5$	A
Output current	$I_O$	2	A
Input voltage	$V_{IN}$	-0.5 to 6	V
Input current	$I_{IN}$	$\pm 10$	mA
Allowable power dissipation	$P_D$	1.5	W
Operating ambient temperature	$T_{opr}$	-40 to +85	°C
Channel temperature	$T_{ch}$	150	°C
Storage temperature	$T_{stg}$	-55 to +150	°C

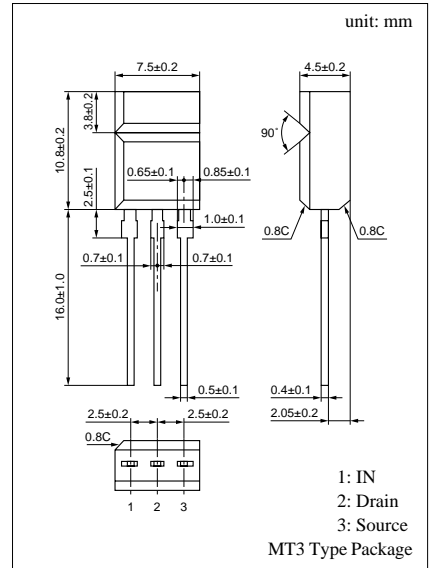

### ■ Block Diagram

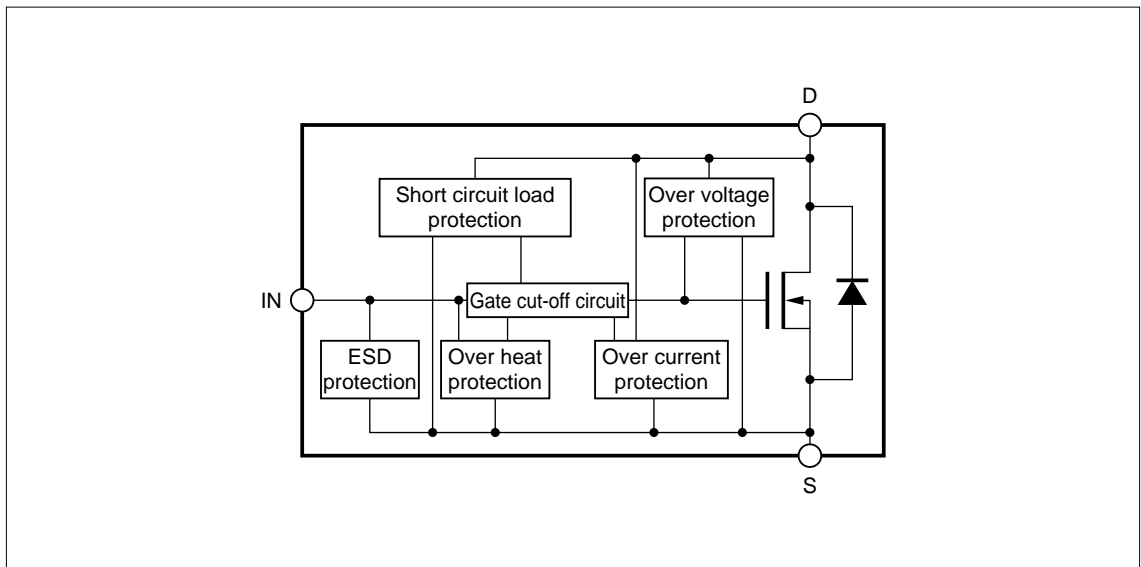

■ Electrical Characteristics ( $T_C = 25 \pm 2^\circ\text{C}$ )

Parameter	Symbol	Conditions	min	typ	max	Unit
Drain to Source ON-resistance	$R_{DS(on)}$	$V_{IN} = 5V, I_{DS} = 1.5A$		0.21	0.3	$\Omega$
Drain to Source ON-voltage	$V_{DS(on)}$	$V_{IN} = 5V, I_{DS} = 1.5A$		0.32	0.45	V
Drain clamp voltage	$V_{DS(CLIP)}$	$V_{IN} = 0, I_{DS} = 3mA$	45	55		V
Drain OFF current (1)	$I_{DS(off)1}$	$V_{IN} = 0, V_{DS} = 12V$			30	$\mu A$
Drain OFF current (2)	$I_{DS(off)2}$	$V_{IN} = 0, V_{DS} = 25V$			60	$\mu A$
Drain OFF current (3)	$I_{DS(off)3}$	$V_{IN} = 0, V_{DS} = 40V$			100	$\mu A$
Input voltage (High)	$V_{IN(H)}$	$I_{DS} = 1.5A$	4.5			V
Input voltage (Low)	$V_{IN(L)}$	$I_{DS} = 0.1mA$			0.8	V
Input current	$I_{IN(on)}$	$V_{IN} = 5V, V_{DS} = 0$		0.15	0.5	mA
Over current protection limit	$I_{OCP}$	$V_{IN} = 5V$	4.7	7.5		A
Short circuit load protection limit	$V_{DS(SHT)}$	$V_{IN} = 5V$	2			V

Note: The oscillation of the output current is caused when the drain voltage exceeds the short circuit load detection voltage under the ON state of output.

■ Electrical Characteristics ( $T_C = 25 \pm 2^\circ\text{C}$ )

Parameter	Symbol	Conditions	min	typ	max	Unit
Over heat protection temperature	$T_{SHD}$	$V_{IN} = 5V$		140		$^\circ\text{C}$
Temperature hysteresis	$\Delta T$	$V_{IN} = 5V$		30		$^\circ\text{C}$

Note 1: The above values of characteristics are not guaranteed values and are only references for designing.

Note 2: When the chip surface temperature exceeds the over heat protection temperature, the output current is shut down. After the chip surface temperature is lowered by an equivalent degree of the temperature hysteresis, the circuits restart their operation.

■ Timing Chart

