

MIP805

Silicon MOS IC

■ Features

- Output MOSFET with high breakdown voltage for voltage step-up, EL driver and CMOS control circuits are integrated into one chip.
- Oscillation circuit is incorporated
- EL voltage controlled push-pull drive system achieves higher EL light intensity. ($160V_{p-p}$)

■ Applications

- EL drive

■ Absolute Maximum Ratings ($T_a = 25^\circ\text{C}$)

Parameter	Symbol	Ratings	Unit
Power supply voltage	V_{CC}	- 0.5 to 6	V
Input voltage (ENB)	V_{ENB}	- 0.5 to $V_{CC} + 0.5$	V
Output voltage (CIL)	V_{CIL}	- 0.5 to 100	V
Output voltage (DC)	V_{DC}	- 0.5 to 100	V
Output voltage (EL)	V_{EL}	- 0.5 to 100	V
Output voltage ($\bar{E}L$)	$V_{\bar{E}L}$	- 0.5 to 100	V
Output current (CIL)	I_{CIL}	80	mA
Output current ($\bar{E}L$)	$I_{\bar{E}L}$	20	mA
Output current (EL)	I_{EL}	20	mA
Allowable power dissipation	P_D	150	mW
Operating ambient temperature	T_{opr}	-20 to +70	$^\circ\text{C}$
Operating Junction temperature	T_{ch}	-20 to +125	$^\circ\text{C}$
Storage temperature	T_{stg}	-55 to +125	$^\circ\text{C}$

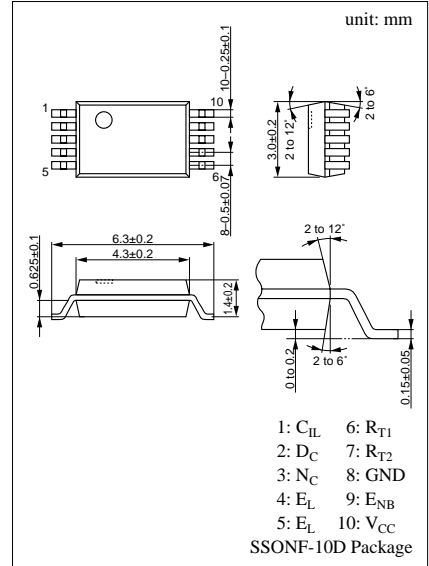

■ Block Diagram

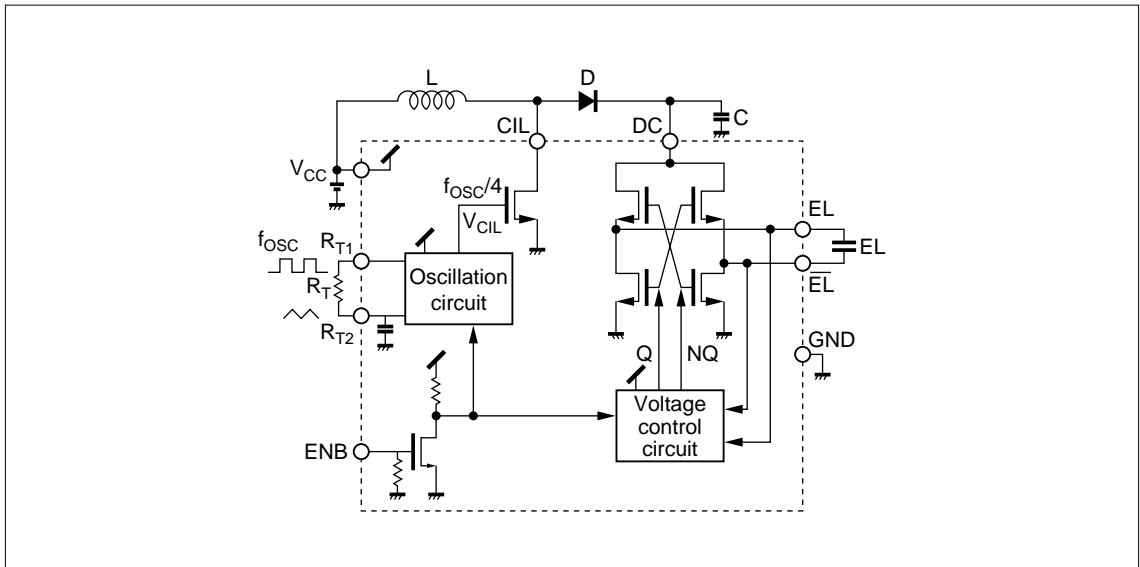

■ Electrical Characteristics (Ta = 25 ± 2°C)

Parameter	Symbol	Conditions*	min	typ	max	Unit	
Operating condition							
Supply voltage	V _{CC}		2.5	3	3.5	V	
Input voltage (High) (ENB)	V _{IH}	V _{CC} = 2.5 to 3.5V	1			V	
Input voltage (Low) (ENB)	V _{IL}	V _{CC} = 2.5 to 3.5V	0		0.3	V	
Oscillation circuit							
Oscillator output frequency (R _{TI})	f _{OSC}	R _T = 270kΩ	98	116	134	kHz	
Inductor frequency (CIL)	f _{COIL}	R _T = 270kΩ	24.5	29	33.5	kHz	
Inductor duty cycle (CIL)	DUTY		70	75	80	%	
Output							
Inductor output (CIL)	Output breakdown voltage	V _{DSS}	E _{NB} = 0, I _{DS} = 100μA	100			V
	Output current	I _{DSS}	V _{DS} = 20V	70			mA
	ON-state resistance	R _{on}	I _D = 10mA		10	15	Ω
	OFF-leakage current	I _{DSS(off)}	E _{NB} = 0, V _{DS} = 80V			10	μA
EL output (EL)	Output current	I _{DSS}	V _{DS} = 20V	10			mA
	OFF-leakage current	I _{DSS(off)}	E _{NB} = 0, V _{DS} = 80V			10	μA
EL output (EL̄)	Output current	I _{DSS}	V _{DS} = 20V	10			mA
	OFF-leakage current	I _{DSS(off)}	E _{NB} = 0, V _{DS} = 80V			10	μA
EL output voltage control							
EL output voltage	V _{EL}		148	160	180	V _{P-P}	
Consumption current							
Quiescent circuit current	I _{COFF}	V _{CC} = 3.5V, V _{ENB} = 0, R _T = 270kΩ			0.1	μA	
Circuit current	I _C	V _{CC} = V _{ENB} = 3.5V, R _T = 270kΩ		0.5	10	μA	

* V_{CC} = 3V, ENB = 3V, and GND = 0 unless otherwise specified

■ Timing Chart

