

Square Type

5.0 mm × 1.5 mm Series

Conventional Part No.	Global Part No.	Lighting Color
LN229RPH	LNG229RFR	Red
LN329GPH	LNG329GFG	Green
LN429YPH	LNG429YFX	Amber

Absolute Maximum Ratings (T_a = 25°C)

Lighting Color	P _D (mW)	I _F (mA)	I _{FP} (mA)*	V _R (V)	T _{opr} (°C)	T _{stg} (°C)
Red	70	25	150	4	-25 ~ +85	-30 ~ +100
Green	90	30	150	4	-25 ~ +85	-30 ~ +100
Amber	90	30	150	4	-25 ~ +85	-30 ~ +100

I_{FP}の条件は duty 10% Pulse width 1 msec. The condition of I_{FP} is duty 10%, Pulse width 1 msec

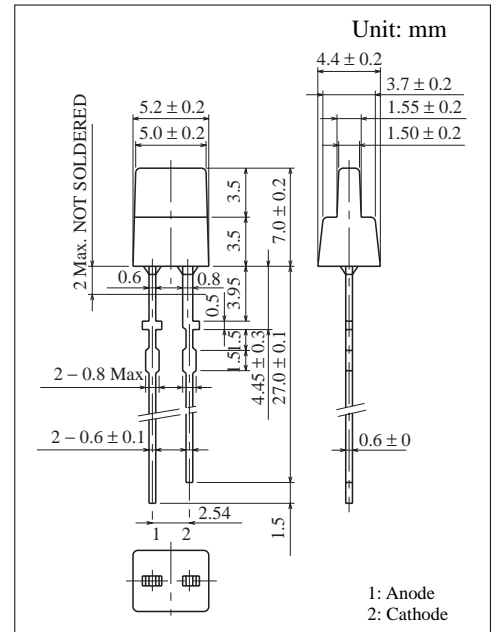

Electro-Optical Characteristics (T_a = 25°C)

Conventional Part No.	Lighting Color	Lens Color	I _O		I _F	V _F		λ _P	Δλ	I _F	I _R	
			Typ	Min		Typ	Max				Max	V _R
LN229RPH	Red	Red Diffused	0.5	0.2	15	2.2	2.8	700	100	20	5	4
LN329GPH	Green	Green Diffused	1.5	0.5	20	2.2	2.8	565	30	20	10	4
LN429YPH	Amber	Amber Diffused	1.5	0.5	20	2.2	2.8	590	30	20	10	4
Unit	—	—	mcd	mcd	mA	V	V	nm	nm	mA	μA	V

