

Ultra High Bright Surface Mounting Chip

InGaAlP S-J Type

Conventional Part No. Global Part No. Lighting Color
 LNJ406K54RX LNJ406K54RX Amber
 LNJ806R58RX LNJ806R58RX Orange

■ Absolute Maximum Ratings (T_a = 25°C)

Lighting Color	P _D (mW)	I _F (mA)	I _{FP} (mA)*	V _R (V)	T _{opr} (°C)	T _{stg} (°C)
Amber	50	20	60	4	-25 ~ +85	-30 ~ +100
Orange	50	20	60	4	-25 ~ +85	-30 ~ +100

I_{FP}の条件は duty 10% Pulse width 1 msec. The condition of I_{FP} is duty 10%, Pulse width 1 msec

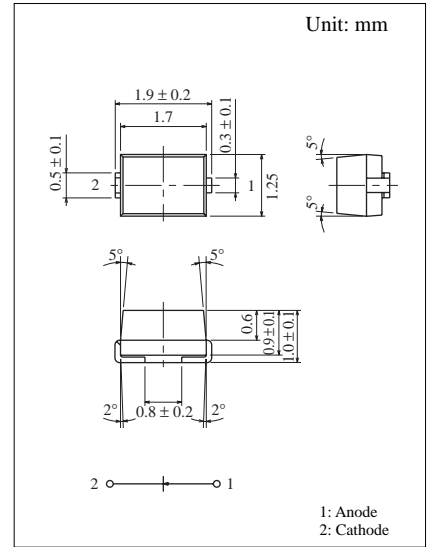

■ Electro-Optical Characteristics (T_a = 25°C)

Conventional Part No.	Lighting Color	Lens Color	I _O		I _F	V _F		λ _p	Δλ	I _F	I _R	
			Typ	Min		Typ	Max				Max	V _R
LNJ406K54RX	Amber	Yellow Diffused	8.5	3.5	10	2.0	2.3	595	15	10	100	4
LNJ806R58RX	Orange	Red Diffused	5.0	2.0	10	1.9	2.3	620	17	10	100	4
Unit	—	—	mcd	mcd	mA	V	V	nm	nm	mA	μA	V

