

Numeric Display

1 Digit 14.4 mm (.6") Series

Conventional Part No.	Global Part No.	Lighting Color
LN516RA	LNM216AA01	Red
LN516RK	LNM216KA01	Red
LN516GA	LNM316AA01	Green
LN516GK	LNM316KA01	Green

Terminal Connection

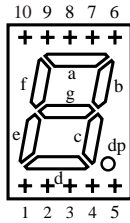

Pin No.	Assignment	Assignment
1	Cathode e	Anode e
2	Cathode d	Anode d
3	Common Anode	Common Cathode
4	Cathode c	Anode c
5	Cathode dp	Anode dp
6	Cathode b	Anode b
7	Cathode a	Anode a
8	Common Anode	Common Cathode
9	Cathode f	Anode f
10	Cathode g	Anode g

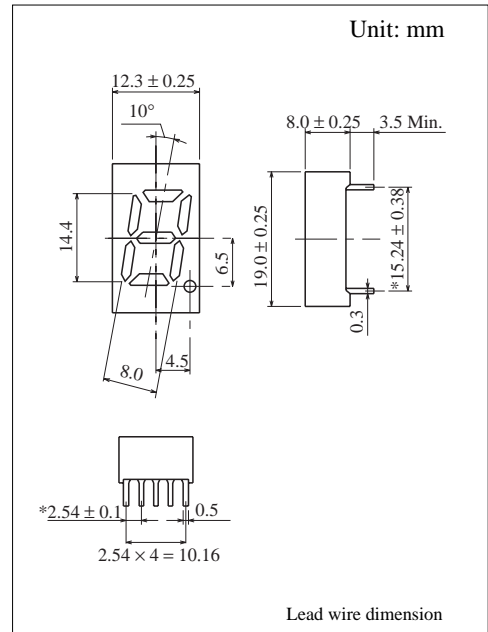

Absolute Maximum Ratings ($T_a = 25^\circ\text{C}$)

Lighting Color	P_D (mW)	I_F (mA)	I_{FP} (mA)*	V_R (V)	T_{opr} ($^\circ\text{C}$)	T_{stg} ($^\circ\text{C}$)
Red	60	20	100	5	-25 ~ +80	-30 ~ +85
Green	60	20	100	5	-25 ~ +80	-30 ~ +85

I_{FP} の条件は duty 10% Pulse width 1 msec. The condition of I_{FP} is duty 10%, Pulse width 1 msec

Electro-Optical Characteristics ($T_a = 25^\circ\text{C}$)

Conventional Part No.	Lighting Color	Common	I_O / seg		I_O / d.p	I_F	V_F		λ_p	$\Delta\lambda$	I_F	I_R	
			Typ	Min			Typ	Typ				Max	Max
LN516RA	Red	Anode	600	250	250	5	2.2	2.8	700	100	20	10	5
LN516RK	Red	Cathode	600	250	250	5	2.2	2.8	700	100	20	10	5
LN516GA	Green	Anode	1500	500	500	10	2.2	2.8	565	30	20	10	5
LN516GK	Green	Cathode	1500	500	500	10	2.2	2.8	565	30	20	10	5
Unit	—	—	μcd	μcd	μcd	mA	V	V	nm	nm	mA	μA	V

