

Numeric Display

1 Digit 7.6 mm (.3") Series

Conventional Part No.	Global Part No.	Lighting Color
LN513YAS	LNM413AS01	Amber
LN513YKS	LNM413KS01	Amber
LN513OAS	LNM813AS01	Orange
LN513OKS	LNM813KS01	Orange

Terminal Connection

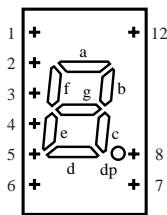

Pin No.	Assignment	Assignment
1	Cathode b	Anode b
2	Cathode a	Anode a
3	Cathode f	Anode f
4	Cathode e	Anode e
5	Cathode d	Anode d
6	Cathode c	Anode c
7	Cathode dp	Anode dp
8	Common Anode	Common Cathode
9	_____	_____
10	_____	_____
11	_____	_____
12	Cathode g	Anode g

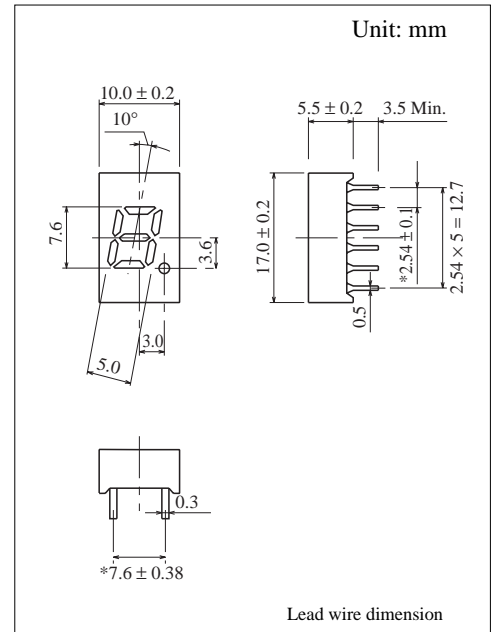

Absolute Maximum Ratings ($T_a = 25^\circ\text{C}$)

Lighting Color	P_D (mW)	I_F (mA)	I_{FP} (mA)*	V_R (V)	T_{opr} ($^\circ\text{C}$)	T_{stg} ($^\circ\text{C}$)
Amber	60	20	100	5	-25 ~ +80	-30 ~ +85
Orange	60	20	100	3	-25 ~ +80	-30 ~ +85

I_{FP} の条件は duty 10% Pulse width 1 msec. The condition of I_{FP} is duty 10%, Pulse width 1 msec

Electro-Optical Characteristics ($T_a = 25^\circ\text{C}$)

Conventional Part No.	Lighting Color	Common	I_O / seg		I_O / d.p		V_F		λ_p	$\Delta\lambda$	I_F	I_R	
			Typ	Min	Typ	I_F	Typ	Max				Typ	Max
LN513YAS	Amber	Anode	600	200	200	10	2.2	2.8	590	30	20	10	5
LN513YKS	Amber	Cathode	600	200	200	10	2.2	2.8	590	30	20	10	5
LN513OAS	Orange	Anode	1000	300	400	10	2.1	2.8	630	40	20	10	3
LN513OKS	Orange	Cathode	1000	300	400	10	2.1	2.8	630	40	20	10	3
Unit	—	—	μcd	μcd	μcd	mA	V	V	nm	nm	mA	μA	V

