

AN7163

BTL 17W Audio Power Amplifier

■ Description

The AN7163 is a monolithic integrated circuit designed exclusively for BTL high power amplifiers in consumer applications. It is suitable for Hi-Fi and car stereo applications.

■ Features

- Built-in protection circuits include: overvoltage, overcurrent, thermal and output-GND short
- Small pop noise during ON/OFF
- High maximum output power (BTL): $P_O = 17W$ at $V_{CC} = 13.2V$, $R_L = 4\Omega$
- Few external components required
- Operating supply voltage: $V_{CC} = 7V \sim 18V$

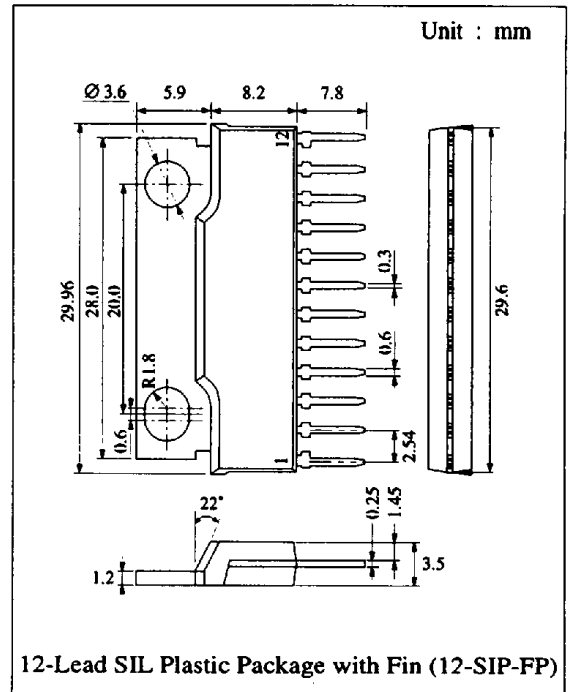

■ Block Diagram

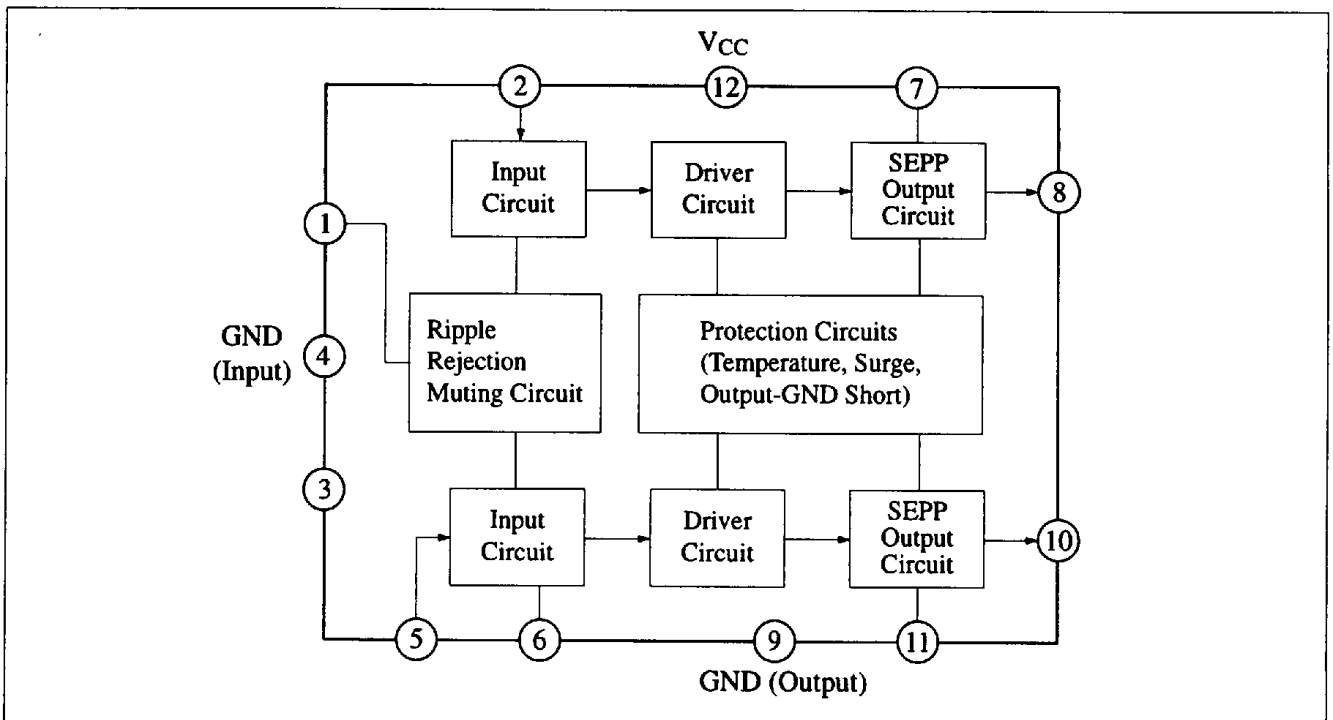

■ Absolute Maximum Ratings ($T_a=25^\circ\text{C}$)

Item	Symbol	Rating	Unit
Supply Voltage	V_{CC}	24	V
Supply Current	I_{CC}	4	A
Power Dissipation	P_D	41.7	W
Surge Supply Voltage	$V_{CC(surge)}$	50	V
Operating Ambient Temperature	T_{opr}	-30 ~ +75	$^\circ\text{C}$
Storage Temperature	T_{stg}	-55 ~ +150	$^\circ\text{C}$

Operating Supply Voltage Range: $V_{CC} = 7.0\text{V} \sim 18.0\text{V}$

■ Electrical Characteristics ($V_{CC}=13.2\text{V}$, $f=1\text{kHz}$, $R_L=4\Omega$, $T_a=25^\circ\text{C}$)

Item	Symbol	Condition	min.	typ.	max.	Unit
Quiescent Current	I_{CQ}	$V_{in} = 0\text{mV}$		40	80	mA
Output Noise Voltage	V_{no}	$V_{in} = 0\text{V}$, $R_g = 10\text{k}\Omega$, $f = 15\text{Hz} \sim 30\text{kHz}$, 12dB/OCT		0.7	1.2	mV
Output Offset Voltage	$V_{O(offset)}$	$V_{in} = 0\text{mV}$	-200		200	mV
Voltage gain	G_v	$V_{in} = 5\text{mV}$	49	51	53	dB
Total Harmonic Distortion	THD	$V_{in} = 5\text{mV}$		0.15	0.5	%
Output Power	P_O	THD = 10%	15	17		W
Ripple Rejection	RR	$V_{in} = 0\text{V}$, $R_g = 0\Omega$, $V_r = 300\text{mV}$, $f_r = 120\text{Hz}$	35	45		dB

■ Pin

Pin No	Pin Name	Pin No	Pin Name
1	Ripple Filter	7	Bootstrap Ch.2
2	N.F.B. Ch.2	8	Output Ch.2
3	Centre Control	9	GND (Output)
4	GND (Input)	10	Output Ch.1
5	Input	11	Bootstrap Ch.1
6	N.F.B. Ch.1	12	V_{CC}

Test Circuit

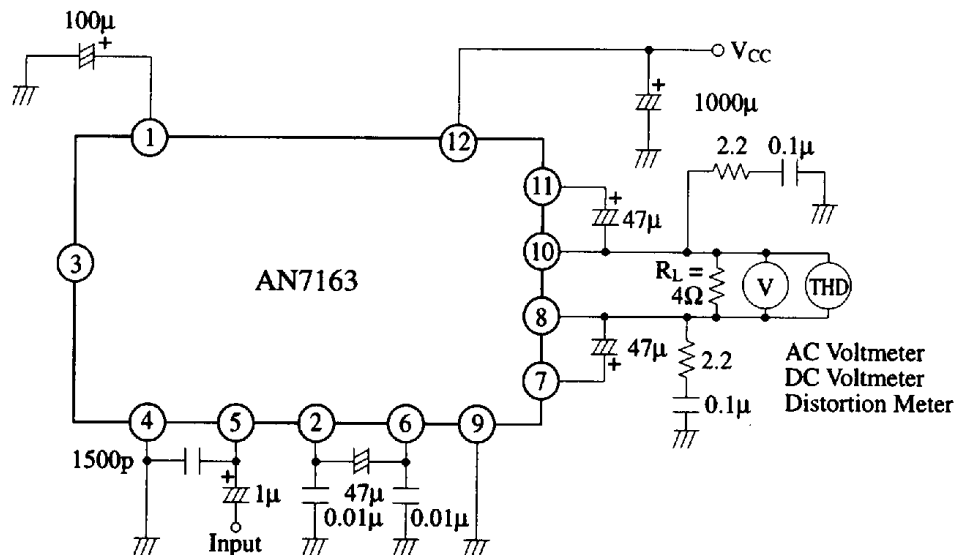

■ Application Circuit

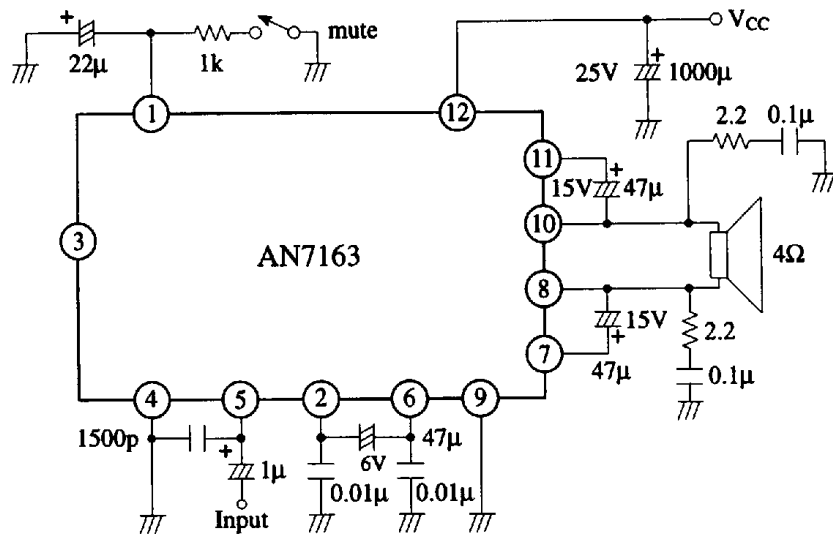

■ Characteristics Curve

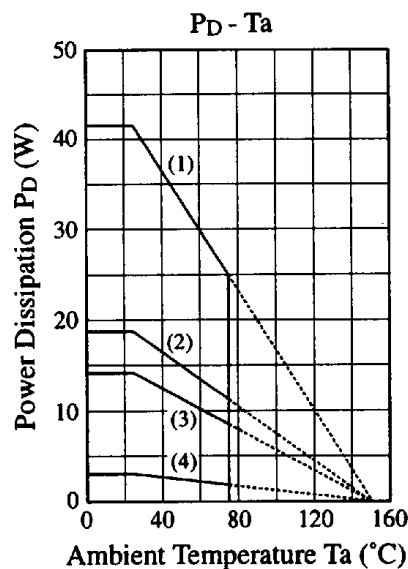
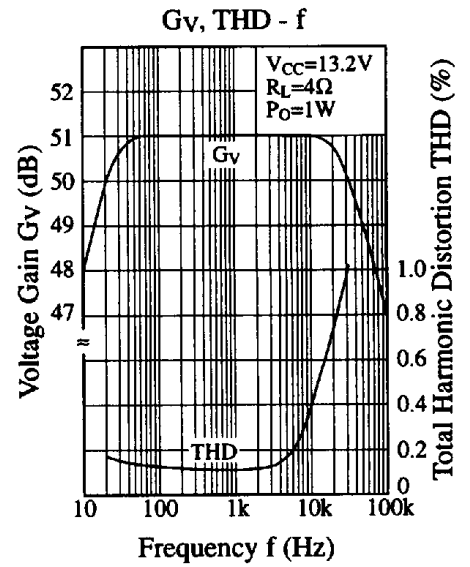
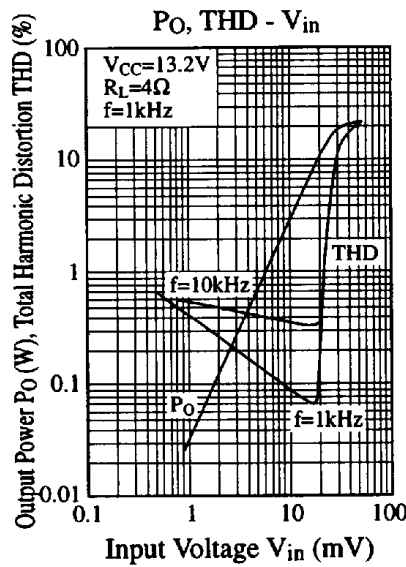
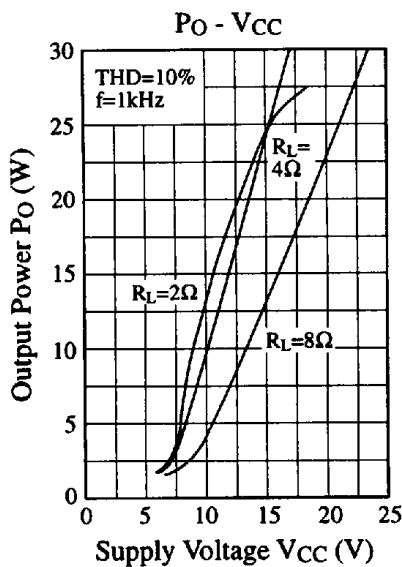

- (1) $T_c = T_a$ ($\theta_{j-c} = 3^\circ\text{C/W}$)
- (2) With a $100\text{cm}^2 \times 3\text{mm}$ Al heat sink (black colour coated) or a $200\text{cm}^2 \times 2\text{mm}$ Al heat sink (not lacquered)
- (3) With a $100\text{cm}^2 \times 2\text{mm}$ Al heat sink (not lacquered)
- (4) Without heat sink