

Features

- High-density 2 megabyte Static RAM module
- Low profile 72-pin ZIP (Zig-zag In-line vertical Package) or 72-pin SIMM (Single In-line Memory Module)
- Fast access time: 15 ns (max.)
- Surface mounted plastic components on an epoxy laminate (FR-4) substrate Single 5V ($\pm 10\%$) power supply
- Multiple V_{SS} pins and decoupling capacitors for maximum noise immunity
- Inputs/outputs directly TTL compatible

Description

The PDM4M4110 is a 512K x 32 static RAM module constructed on an epoxy laminate (FR-4) substrate using four (4) 512K x 8 static RAMs in plastic SOJ packages. Availability of four chip select lines provides byte access. The PDM4M4110 is available with access times as fast as 15 ns with minimal power consumption.

The PDM4M4110 is packaged in a 72-pin FR-4 ZIP (Zig-zag In-line vertical Package) or a 72-pin SIMM (Single In-line Memory Module). The ZIP configuration allows 72 pins to be placed on a package 3.95" long and 0.250" wide. At only 0.600" high, this low-profile package is ideal for systems with minimum board spacing. The SIMM configuration allows use of edge mounted sockets to secure the module.

All inputs and outputs of the PDM4M4110 are TTL compatible and operate from a single 5V supply. Multiple ground pins and on board decoupling capacitors provide maximum immunity from noise.

Four identification pins (PD0, PD1, PD2, PD3) are provided for applications in which different density versions of the module are used. In this way, the target system can read the respective levels of PD0, PD1, PD2, PD3 to determine a 512K depth.

Functional Block Diagram

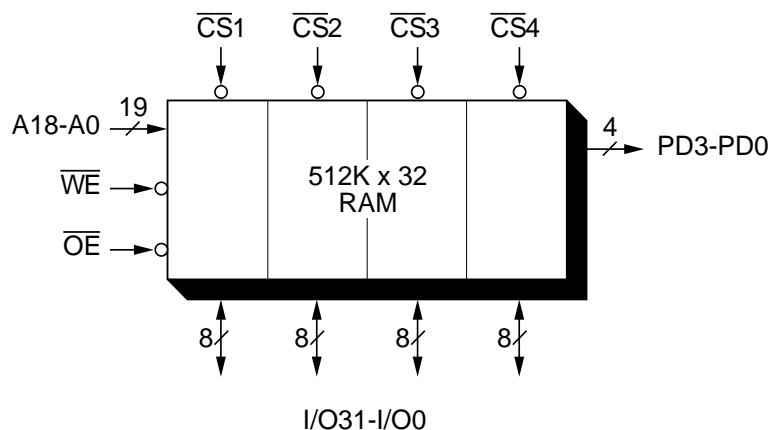

Pin Configuration⁽¹⁾

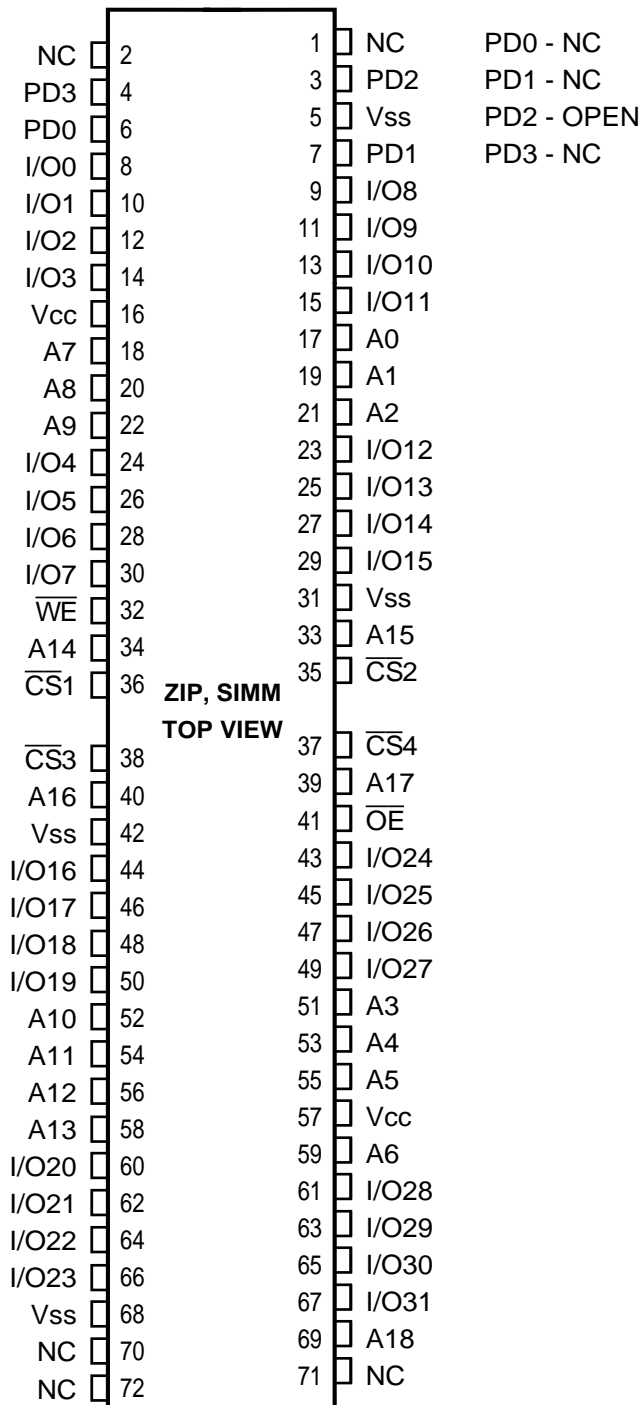

Pin Assignment

Pin	Signal
I/O31-I/O0	Data Inputs/Outputs
A18-A0	Addresses
CS4-CS1	Chip Selects
WE	Write Enable
OE	Output Enable
PD3-PD0	Depth Identification
Vcc	Power
Vss	Ground
NC	No Connect

NOTE: 1. Pins 3, 4, 6, and 7 (PD0, PD1, PD02, and PD3 respectively) are read by the user to determine the density of the module. If PD0 reads NC, PD1 reads NC, PD2 reads OPEN, PD3 reads NC then the module has a 512K depth.

Truth Table

Mode	\overline{CS}	\overline{OE}	\overline{WE}	Output	Power
Deselect/ Power-down	H	X	X	High-Z	Standby
Read	L	L	H	DATA _{OUT}	Active
Write	L	X	L	DATA _{IN}	Active
Deselect	L	H	H	High-Z	Active

Absolute Maximum Ratings⁽¹⁾

Symbol	Rating	Com'l.	Ind.	Unit
V _{TERM}	Terminal Voltage with Respect to V _{SS}	-0.5 to +7.0	-0.5 to +7.0	V
T _{BIAS}	Temperature Under Bias	-10 to +85	-10 to +85	°C
T _{STG}	Storage Temperature	-55 to +125	-65 to +150	°C
T _A	Operating Temperature	0 to +70	0 to +70	°C
P _T	Power Dissipation	1.0	1.0	W
I _{OUT}	DC Output Current	50	50	mA

NOTE: 1. Stresses greater than those listed under ABSOLUTE MAXIMUM RATINGS may cause permanent damage to the device. This is a stress rating only and functional operation of the device at these or any other conditions above those indicated in the operational sections of this specification is not implied. Exposure to absolute maximum rating conditions for extended periods may affect reliability.

Recommended DC Operating Conditions

Symbol	Parameter	Min.	Typ.	Max.	Unit
V _{CC}	Supply Voltage	4.5	5.0	5.5	V
V _{SS}	Supply Voltage	0	0	0	V
Commercial	Ambient Temperature	0	25	70	°C

DC Electrical Characteristics ($V_{CC} = 5.0V \pm 10\%$, $T_A = 0^\circ C$ to $+70^\circ C$)

Symbol	Parameter	Test Conditions	Min.	Max.	Unit
I_{LI}	Input Leakage Current (Address and Control)	$V_{CC} = \text{Max.}, V_{IN} = V_{SS}$ to V_{CC}	—	40	μA
I_{LI}	Input Leakage Current (Data)	$V_{CC} = \text{Max.}, V_{IN} = V_{SS}$ to V_{CC}	—	10	μA
I_{LO}	Output Leakage Current	$V_{OUT} = V_{SS}$ to $V_{CC}, V_{CC} = \text{Max.}, \overline{CS} = V_{IH}$	—	10	μA
V_{OL}	Output Low Voltage	$I_{OL} = 8 \text{ mA}, V_{CC} = \text{Min.}$	—	0.4	V
V_{OH}	Output High Voltage	$I_{OL} = -4 \text{ mA}, V_{CC} = \text{Min.}$	2.4	—	V
V_{IH}	Input High Voltage		2.2	6.0	V
V_{IL}	Input Low Voltage		$-0.5^{(1)}$	0.8	V

NOTE 1. $V_{IL} = -2.0V$ for pulse widths less than 10 ns, once per cycle.

Power Supply Characteristics

Symbol	Parameter	Max ⁽¹⁾	Unit
I_{CC}	Operating Current $\overline{CS} = V_{IL}, V_{CC} = \text{Max.}, f = f_{MAX}, \text{Outputs Open}$	680	mA
I_{SB}	Standby Current $\overline{CS} \geq V_{IH}, V_{CC} = \text{Max.}, f = f_{MAX}, \text{Outputs Open}$	160	mA
I_{SB1}	Full Standby Current $\overline{CS} \geq V_{CC} - 0.2V,$ $f = 0, V_{IN} > V_{CC} - 0.2V$ or $< 0.2V$	60	mA

NOTE 1. Preliminary specification only.

Capacitance⁽¹⁾ ($T_A = +25^\circ C, f = 1.0 \text{ MHz}$)

Symbol	Parameter	Max.	Unit
$C_{IN(D)}$	Input Capacitance, (Data) $V_{IN} = 0V$	12	pF
$C_{IN(A)}$	Input Capacitance, (Address and Control) $V_{IN} = 0V$	40	pF
C_{OUT}	Input Capacitance, $V_{OUT} = 0V$	12	pF

NOTE 1. This parameter is determined by device characteristics but is not production tested.

AC Test Conditions

Input Pulse Levels	V_{SS} to 3.0V
Input Rise/Fall Times	5 ns
Input Timing Reference Levels	1.5V
Output Reference Levels	1.5V
Output Load	See Figures 1 and 2

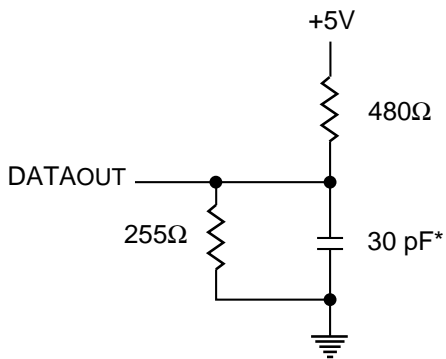

* Including scope and jig capacitances

Figure 1. Output Load

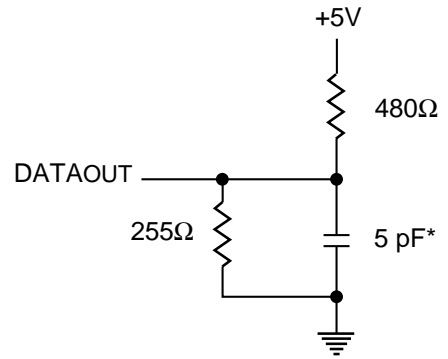

* Including scope and jig capacitances

Figure 2. Output Load
(for tOHZ, tCHZ, tOLZ, and tCLZ)

AC Electrical Characteristics ($V_{CC} = 5V \pm 10\%$, $T_A = 0^\circ C$ to $+70^\circ C$)

Symbol	Parameter	PDM4M4110SXXZ, PDM4M4110SXXM								Unit
		-15 ns		-20 ns		-25 ns		-35 ns		
		Min.	Max.	Min.	Max.	Min.	Max.	Min.	Max.	
Read Cycle										
t_{RC}	Read Cycle Time	15	—	20	—	25	—	35	—	ns
t_{AA}	Address Access Time	—	15	—	20	—	25	—	35	ns
t_{ACS}	Chip Select Access Time	—	15	—	20	—	25	—	35	ns
$t_{CLZ}^{(1)}$	Chip Select to Output in Low-Z	5	—	3	—	3	—	3	—	ns
t_{OE}	Output Enable to Output Valid	—	6	—	10	—	12	—	15	ns
$t_{OLZ}^{(1)}$	Output Enable to Output in Low-Z	0	—	0	—	0	—	0	—	ns
$t_{CHZ}^{(1)}$	Chip Deselect to Output in High-Z	—	10	—	12	—	14	—	16	ns
$t_{OHZ}^{(1)}$	Output Disable to Output in High-Z	—	6	—	8	—	10	—	12	ns
t_{OH}	Output Hold from Address Change	3	—	3	—	3	—	3	—	ns
$t_{PU}^{(1)}$	Chip Select to Power-Up Time	0	—	0	—	0	—	0	—	ns
$t_{PD}^{(1)}$	Chip Deselect to Power-Down Time	—	15	—	20	—	25	—	35	ns
Write Cycle										
t_{WC}	Write Cycle Time	15	—	20	—	25	—	35	—	ns
t_{CW}	Chip Select to End of Write	13	—	18	—	20	—	25	—	ns
t_{AW}	Address Valid to End of Write	13	—	18	—	20	—	25	—	ns
$t_{AS}^{(2)}$	Address Setup Time	3	—	3	—	3	—	3	—	ns
t_{WP}	Write Pulse Width	13	—	15	—	17	—	22	—	ns
$t_{WR}^{(2)}$	Write Recovery Time	0	—	0	—	0	—	0	—	ns
$t_{WHZ}^{(1)}$	Write Enable to Output in High-Z	—	8	—	8	—	13	—	15	ns
t_{DW}	Data to Write Time Overlap	10	—	12	—	15	—	20	—	ns
$t_{DH}^{(2)}$	Data Hold from Write Time	0	—	0	—	0	—	0	—	ns
$t_{OW}^{(1)}$	Output Active from End of Write	2	—	2	—	2	—	2	—	ns

- NOTE 1. This parameter is determined by device characteristics but is not production tested.
 2. $t_{AS} = 0$ ns for \overline{CS} controlled write cycles. t_{DH} , $t_{WR} = 3$ ns for \overline{CS} controlled write cycles

Timing Waveforms of Read Cycle No.1⁽¹⁾

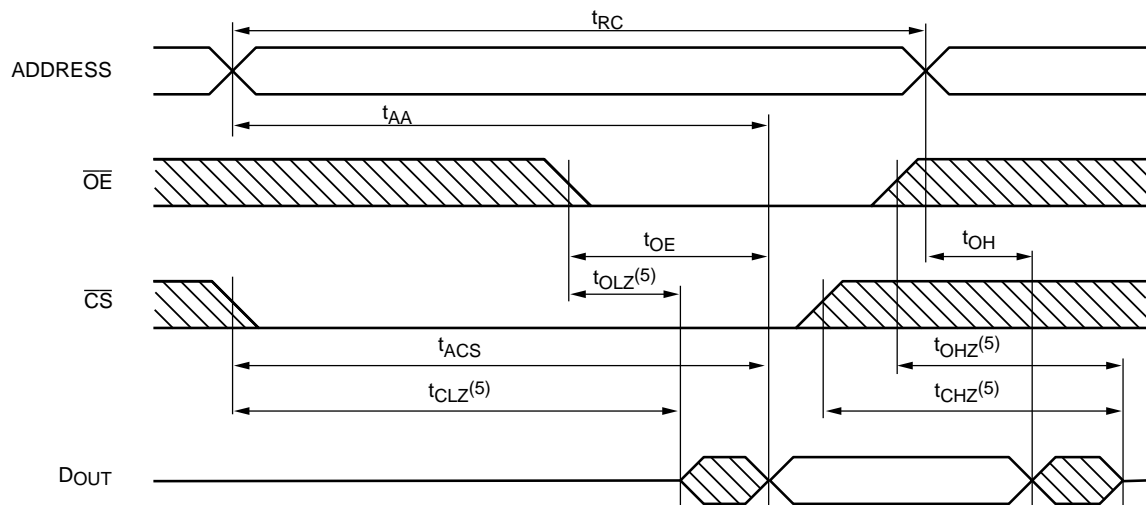

Timing Waveforms of Read Cycle No.2^(1,2,4)

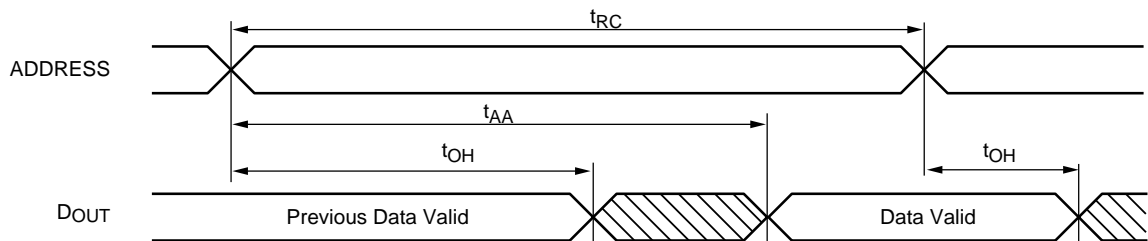

Timing Waveforms of Read Cycle No.3^(1,3,4)

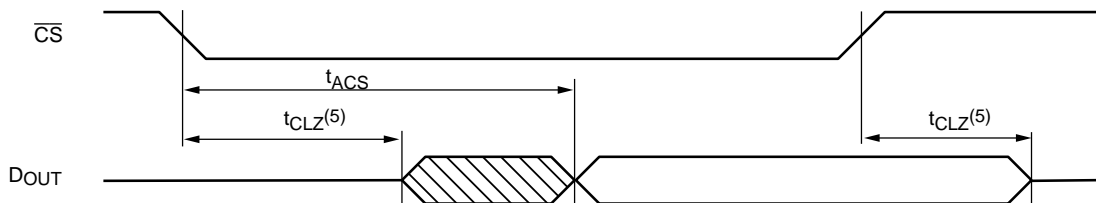

- NOTES
1. \overline{WE} is HIGH for Read Cycle.
 2. Device is continuously selected. $\overline{CS} = V_{IL}$.
 3. Address valid prior to or coincident with \overline{CS} transition LOW.
 4. $\overline{OE} = V_{IL}$.
 5. Transition is measured ± 200 mV for steady state. This parameter is determined by device characteristics but is not production tested.

Timing Waveforms of Write Cycle No.1⁽¹⁾

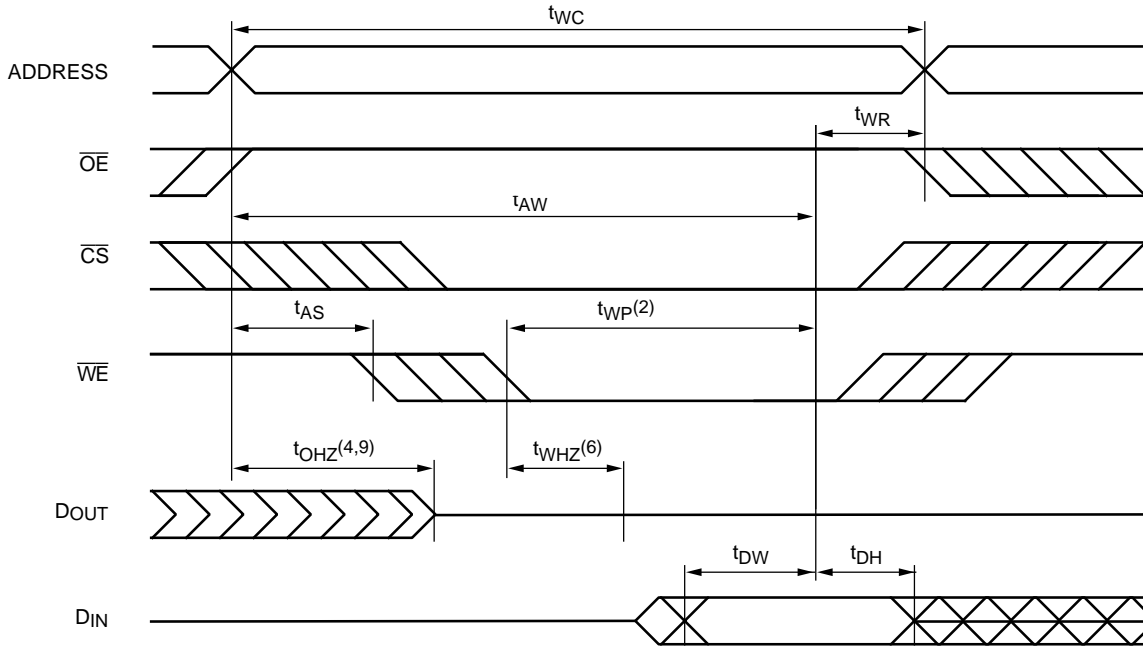

Timing Waveforms of Write Cycle No.2^(1,6)

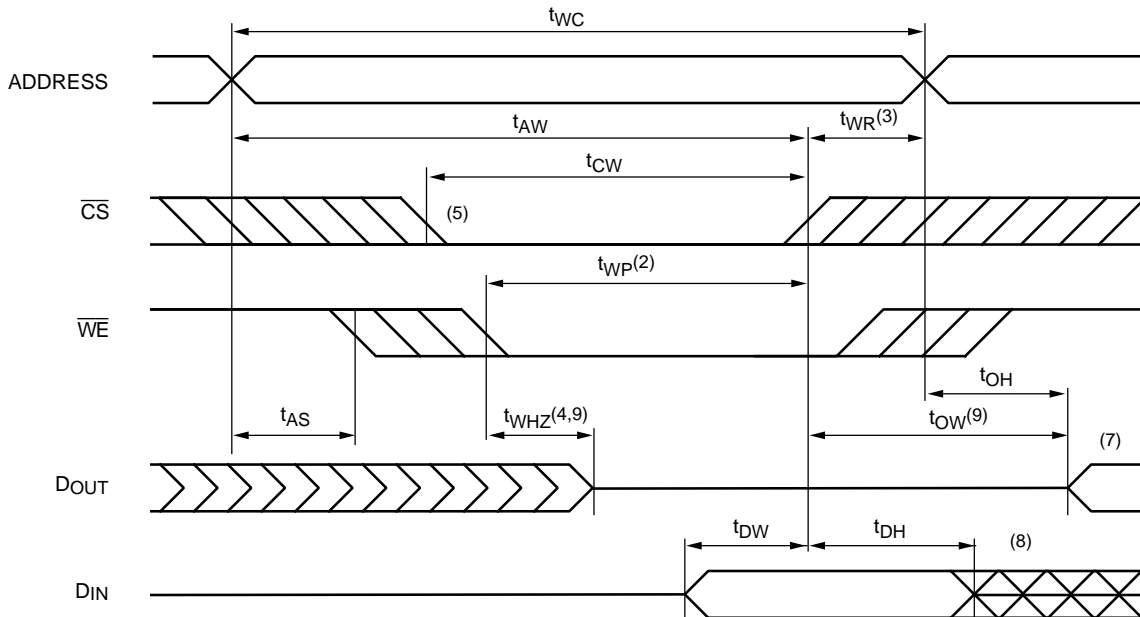

- NOTES
1. \overline{WE} or \overline{CS} must be HIGH during all address transitions.
 2. A write occurs during the overlap (t_{WP}) of a LOW \overline{CS} .
 3. t_{WR} is measured from the earlier of \overline{CS} or \overline{WE} going HIGH to end the write cycle.
 4. During this period, I/O pins are in the output state, and input signals to the opposite phase to the outputs must not be applied.
 5. If the \overline{CS} LOW transition occurs simultaneously with or after the \overline{WE} LOW transition, the outputs remain in a high-impedance state.
 6. \overline{OE} is continuously LOW ($\overline{OE} = V_{IL}$)
 7. D_{OUT} is the same phase of write data of this write cycle.
 8. If \overline{CS} is LOW during this period, I/O pins are in the output state. Then the data input signals of the opposite phase to the outputs must not be applied to them.
 9. Transition is measured ± 200 mV for steady state with a 5 pF load (including scope and jig). This parameter is determined by device characteristics but is not production tested.

Package Dimensions

ZIP Version

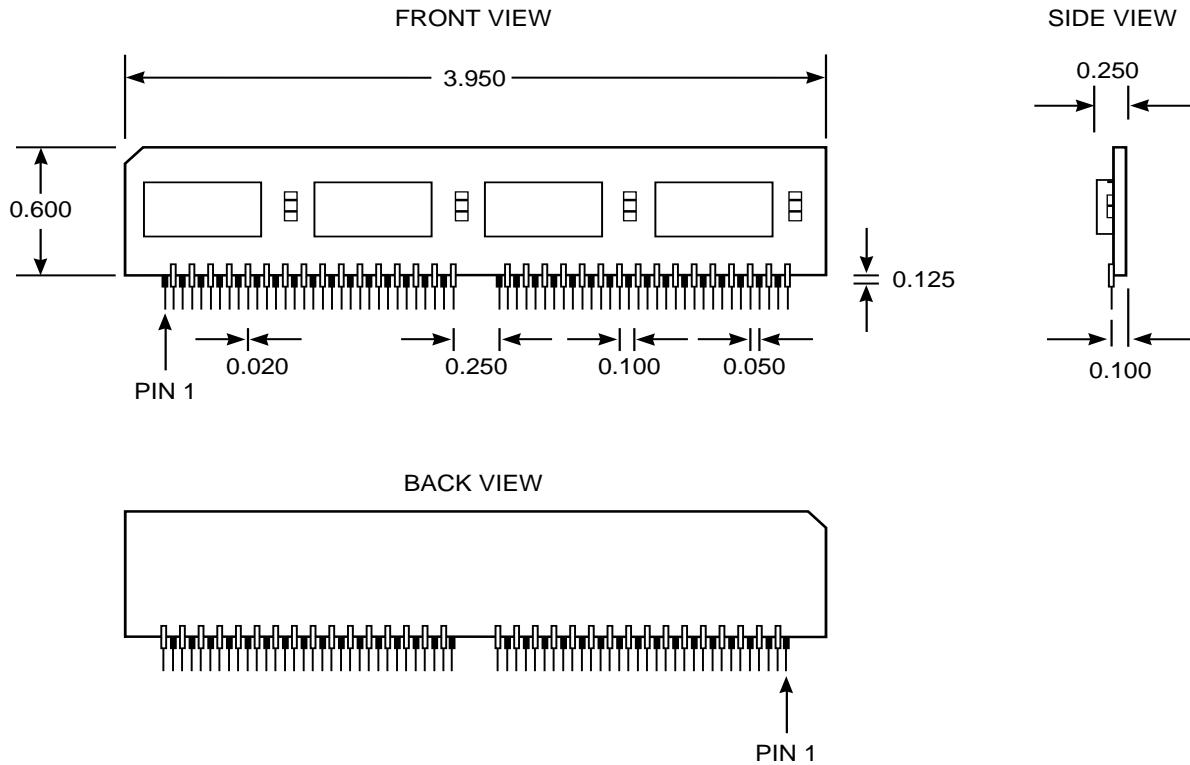

SIMM Version

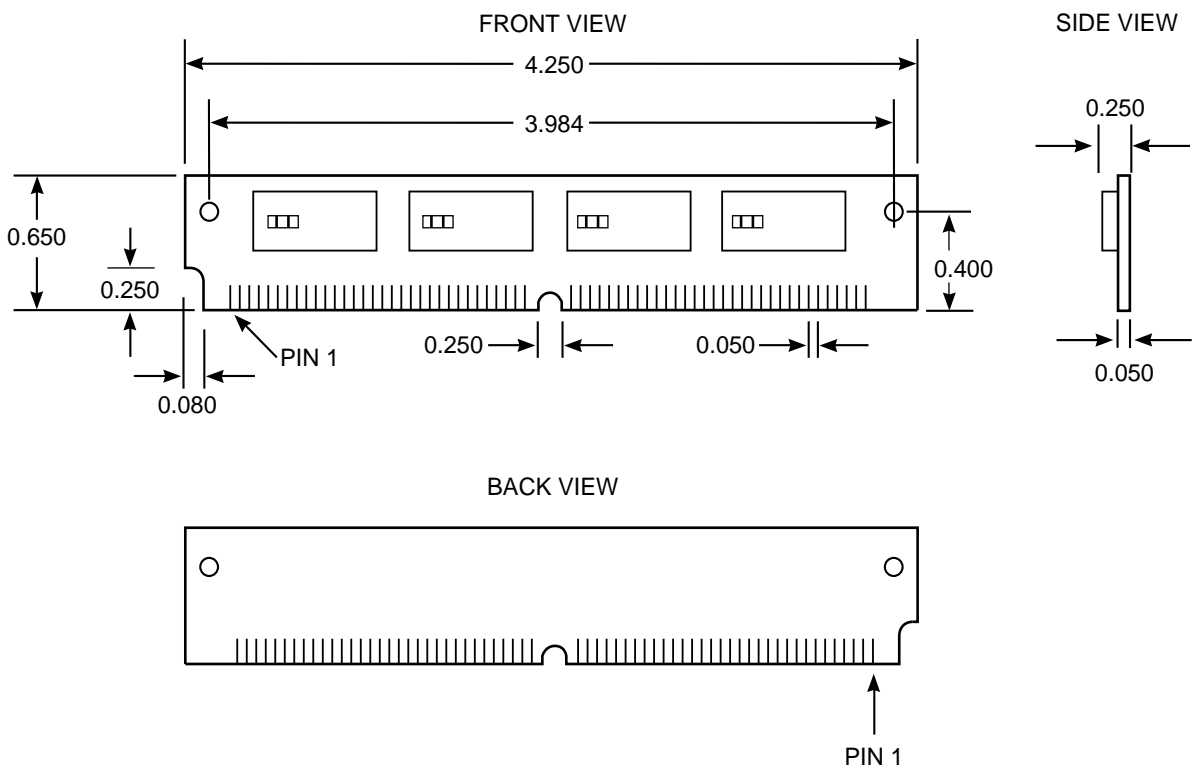

Ordering Information

