

Product Features

- Near-zero propagation delay
- 5Ω switches connect inputs to outputs
- Fast Switching speed - 5ns (max.)
- Operating Range: 3.0V to 3.6V
- Industrial operating temperature: -40°C to +85°C
- Packages available:
 - 48-pin 240-mil wide thin plastic TSSOP (A)
 - 48-pin 300-mil wide plastic SSOP (V)

Product Description

Pericom Semiconductor's PI3B series of logic circuits are produced in the Company's advanced 0.35 micron CMOS technology.

The PI3B16209 and PI3B162209 are 3.3 volt, 18-bit bus exchange switches designed with a low ON resistance (5Ω) allowing inputs to be connected directly to outputs. The devices operate as an 18-bit bus switch or as a 9-bit exchanger, providing data exchange between the four signal ports via the data select pins (S0-S2).

The PI5C162209 device has a built-in 25-ohm series resistor to reduce noise resulting from reflections, thus eliminating the need for an external terminating resistor.

Logic Block Diagram

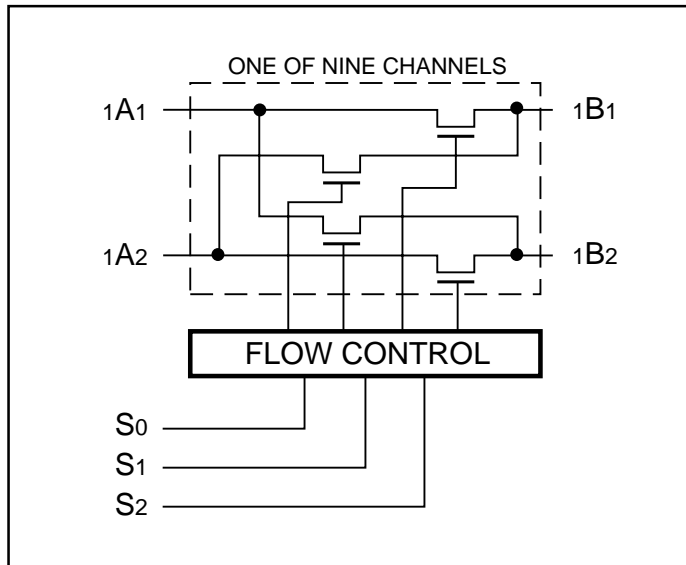

Product Pin Configuration

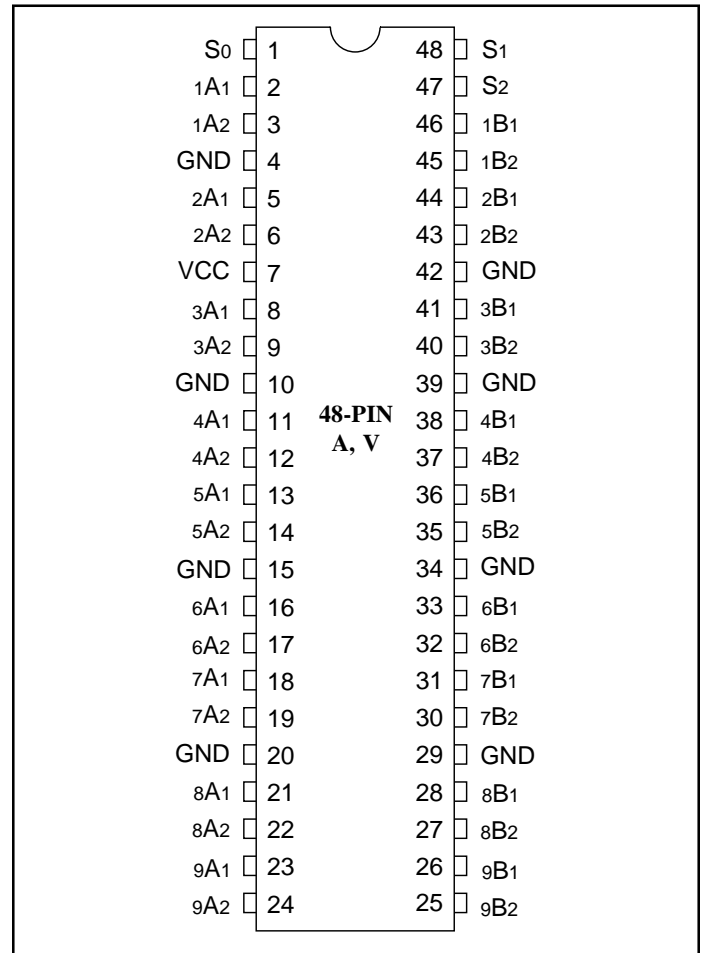

Truth Table

Function	S2	S1	S0	A1	A2
Disconnect	L	L	L	Z	Z
A1 to B1	L	L	H	B1	Z
A1 to B2	L	H	L	B2	Z
A2 to B1	L	H	H	Z	B1
A2 to B2	H	L	L	Z	B2
Disconnect	H	L	H	Z	Z
A1 to B1, A2 to B2	H	H	L	B1	B2
A1 to B2, A2 to B1	H	H	H	B2	B1

Note:

1. H = High Voltage Level
L = Low Voltage Level
Z = High Impedance

Product Pin Description

Pin Name	I/O	Description
S0-S2	I	Select Inputs
xAx	I/O	Bus A
xBx	I/O	Bus B

Maximum Ratings

(Above which the useful life may be impaired. For user guidelines, not tested.)

Storage Temperature	-65°C to +150°C
Ambient Temperature with Power Applied	-0°C to +85°C
Supply Voltage Range	-0.5V to +4.6V
DC Input Voltage	-0.5V to +4.6V
DC Output Current	120 mA
Power Dissipation	0.5W

Note:

Stresses greater than those listed under **MAXIMUM RATINGS** may cause permanent damage to the device. This is a stress rating only and functional operation of the device at these or any other conditions above those indicated in the operational sections of this specification is not implied. Exposure to absolute maximum rating conditions for extended periods may affect reliability.

DC Electrical Characteristics (Over the Operating Range, $T_A = -40^\circ\text{C}$ to $+85^\circ\text{C}$, $V_{CC} = 3.0\text{V}$ to 3.6V)

Parameters	Description	Test Conditions ⁽¹⁾	Min.	Typ ⁽²⁾	Max.	Units	
V _{IH}	Input HIGH Voltage	Guaranteed Logic HIGH Level	2.0	—	—	V	
V _{IL}	Input LOW Voltage	Guaranteed Logic LOW Level	-0.5	—	0.8	V	
I _{IH}	Input HIGH Current	$V_{CC} = \text{Max.}, V_{IN} = V_{CC}$	—	—	±1	μA	
I _{IL}	Input LOW Current	$V_{CC} = \text{Max.}, V_{IN} = \text{GND}$	—	—	±1	μA	
I _{OZH}	High Impedance Output Current	$0 \leq A, B \leq V_{CC}$	—	—	±1	μA	
V _{IK}	Clamp Diode Voltage	$V_{CC} = \text{Min.}, I_{IN} = -18\text{mA}$	—	-0.7	-1.2	V	
R _{ON}	Switch On Resistance ⁽³⁾	$V_{CC} = \text{Min.}, V_{IN} = 0.0\text{V},$ $I_{ON} = 48\text{mA}$	16209	—	5	8	Ω
			162209	20	28	40	
		$V_{CC} = \text{Min.}, V_{IN} = 2.4\text{V},$ $I_{ON} = 15\text{mA}$	16209	—	10	15	Ω
			162209	20	35	48	

Capacitance ($T_A = 25^\circ\text{C}$, $f = 1\text{ MHz}$)

Parameters ⁽⁴⁾	Description	Test Conditions	Typ	Units
C _{IN}	Input Capacitance	$V_{IN} = 0\text{V}$	3	pF
C _{OFF}	A/B Capacitance, Switch Off	$V_{IN} = 0\text{V}$	14	pF
C _{ON}	A/B Capacitance, Switch On	$V_{IN} = 0\text{V}$	30	pF

Notes:

- For Max. or Min. conditions, use appropriate value specified under Electrical Characteristics for the applicable device type.
- Typical values are at $V_{CC} = 3.3\text{V}$, $T_A = 25^\circ\text{C}$ ambient and maximum loading.
- Measured by the voltage drop between A and B pin at indicated current through the switch. ON resistance is determined by the lower of the voltages on the two (A,B) pins.
- This parameter is determined by device characterization but is not production tested.

Power Supply Characteristics

Parameters	Description	Test Conditions ⁽¹⁾		Min.	Typ ⁽²⁾	Max.	Units
I _{CC}	Quiescent Power Supply Current	V _{CC} = Max.	V _{IN} = GND or V _{CC}			10	μA
ΔI _{CC}	Supply Current per Input @ TTL HIGH	V _{CC} = Max.	V _{IN} = 3.0V ⁽³⁾			750	μA
I _{CCD}	Supply Current per Input per MHz ⁽⁴⁾	V _{CC} = Max. A and B Pins Open BE = GND Control Input Toggling 50% Duty Cycle				0.25	mA/ MHz

Notes:

1. For Max. or Min. conditions, use appropriate value specified under Electrical Characteristics for the applicable device.
2. Typical values are at V_{CC} = 3.3V, +25°C ambient.
3. Per TTL driven input (control input only); A and B pins do not contribute to I_{CC}.
4. This current applies to the control inputs only and represent the current required to switch internal capacitance at the specified frequency. The A and B inputs generate no significant AC or DC currents as they transition. This parameter is not tested, but is guaranteed by design.

Switching Characteristics over Operating Range

Parameters	Description	Conditions ⁽¹⁾	Com.		Units
			Min.	Max.	
t _{PLH}	Propagation Delay ^(2,3)	CI = 50pF RI = 500Ω	16209	0.25	ns
t _{PHL}	Ax to Bx, Bx to Ax		162209	1.25	
t _{PZH}	Bus Enable Time	CI = 50pF, R _L = 500Ω, R = 500Ω	1	4.5	
t _{PZL}	BE to Ax or Bx				
t _{PHZ}	Bus Disable Time		1	5	
t _{PLZ}	BE to Ax or Bx				

Notes:

1. See test circuit and waveforms.
2. This parameter is guaranteed but not tested on Propagation Delays.
3. The bus switch contributes no propagational delay other than the RC delay of the ON resistance of the switch and the load capacitance. The time constant for the switch alone is of the order of 0.25 ns for 50 pF load. Since this time constant is much smaller than the rise/fall times of typical driving signals, it adds very little propagational delay to the system. Propagational delay of the bus switch when used in a system is determined by the driving circuit on the driving side of the switch and its interaction with the load on the driven side.