

Product Features

- Near-zero propagation delay
- R_{ON} is 5Ω typical at 3.3V
- Fast Switching speed: 4.5ns (max.)
- V_{CC} operating range: 3.0V to 3.6V
- 500 ohm pulldown to unconnected B port
- Industrial operating temperature: -40°C to $+85^{\circ}\text{C}$
- Make-before-break action
- Packages available:
– 80-pin BQSOP (B)

Product Description

Pericom Semiconductor’s PI3B series of logic circuits are produced using the Company’s advanced 0.35 micron CMOS technology.

The PI3B16248 is a 3.3V, 24-bit to 48-bit Mux/Demux Bus Switch designed with a low ON resistance allowing inputs to be connected directly to outputs.

Logic Block Diagram

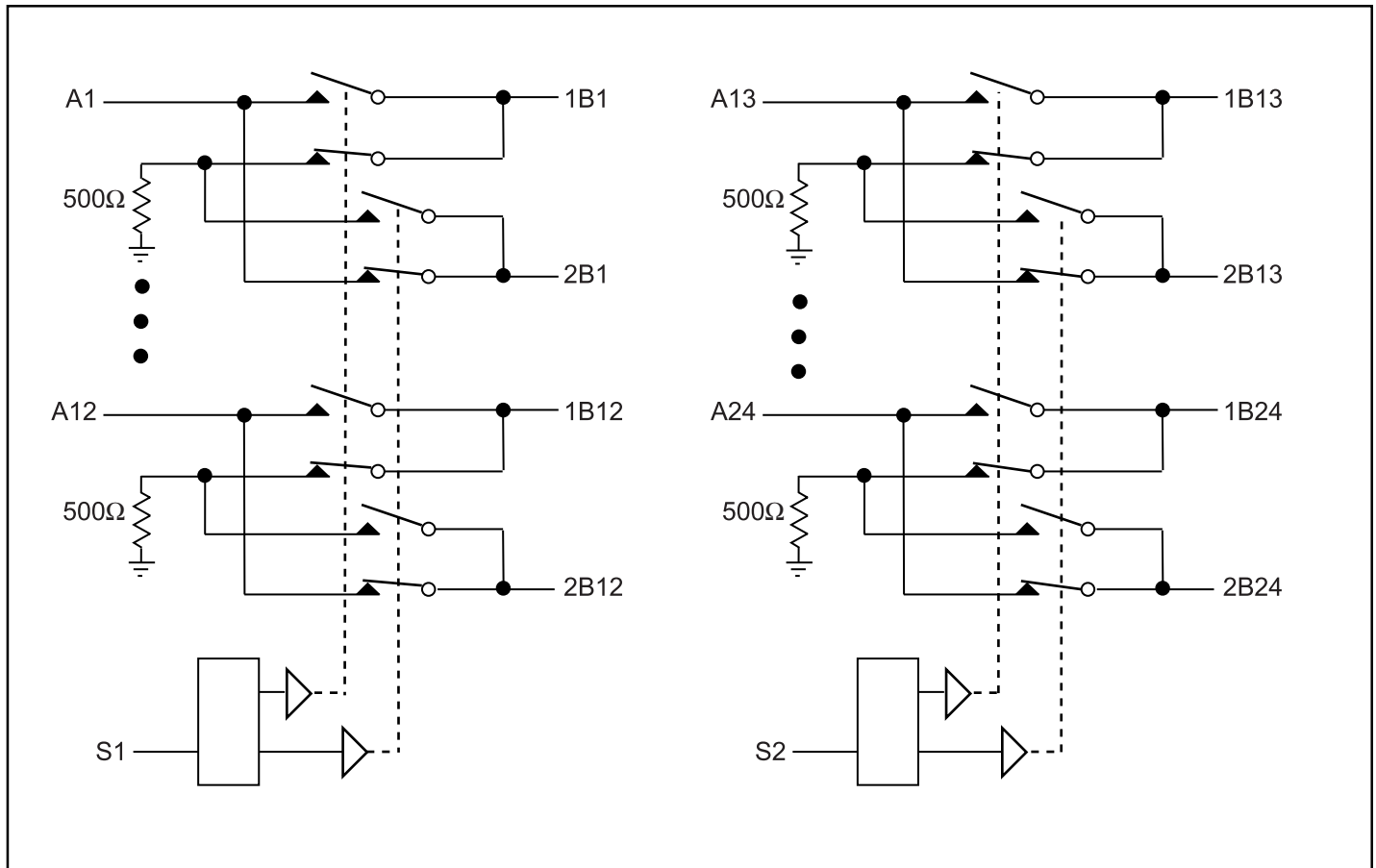

Truth Table⁽¹⁾

Function	S2/S1	A
A to 1B	L	1B
A to 2B	H	2B

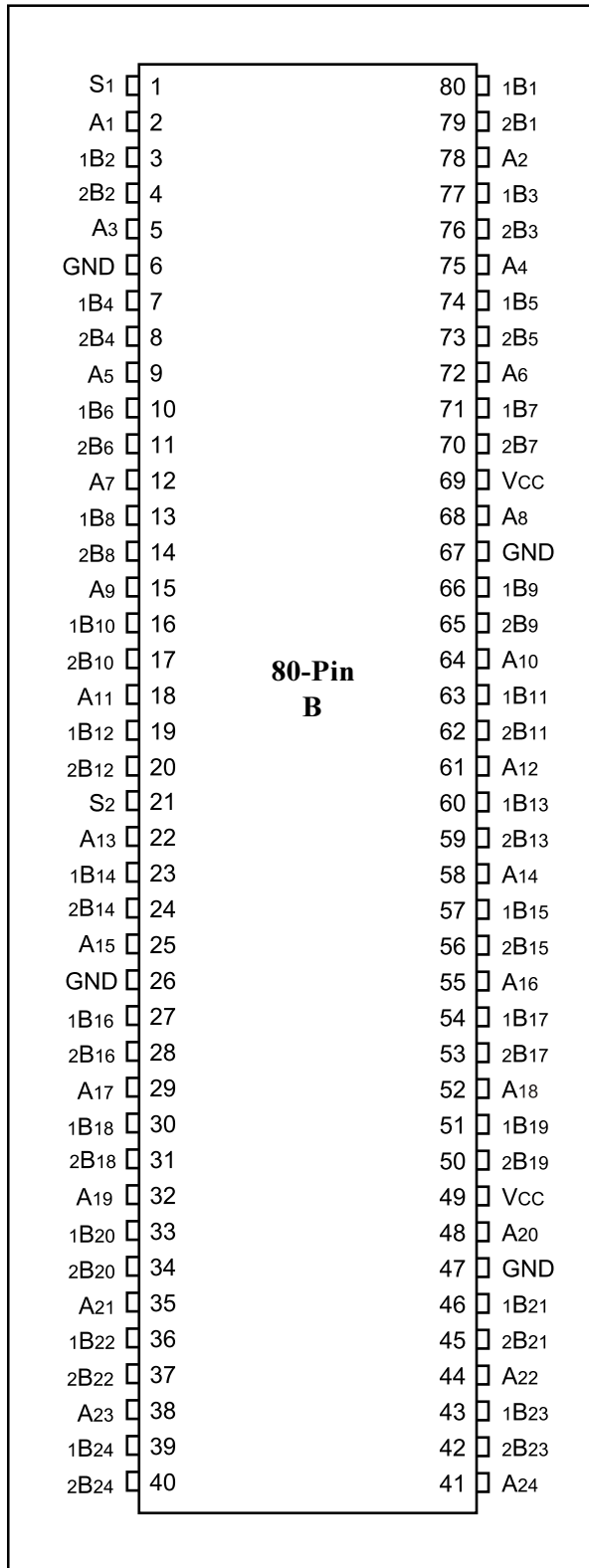
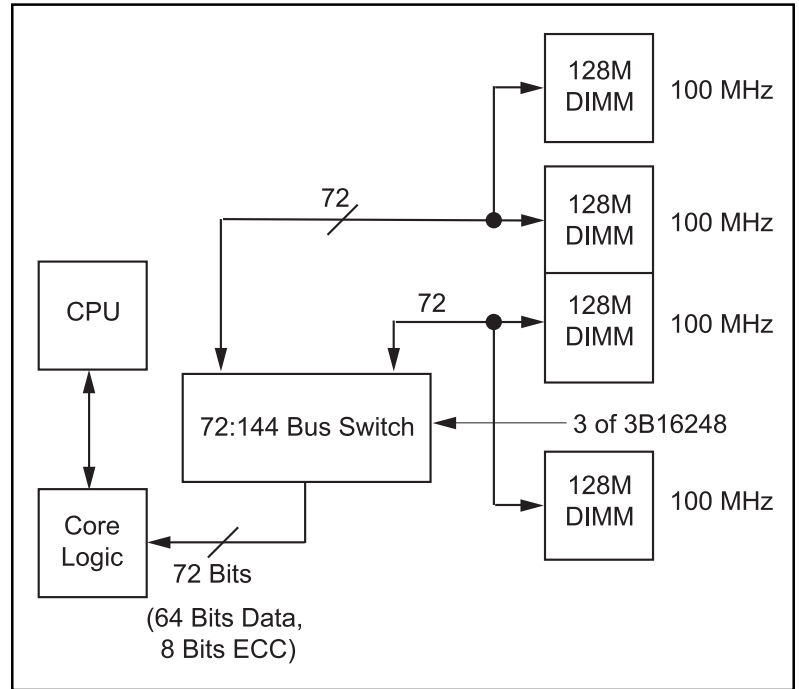
Product Pin Configuration

Application Circuit

Maximum Ratings

(Above which the useful life may be impaired. For user guidelines, not tested.)

Storage Temperature	-65°C to +150°C
Ambient Temperature with Power Applied	-40°C to +85°C
Supply Voltage Range	-0.5V to +4.6V
DC Input Voltage	-0.5V to +4.6V
DC Output Current	120mA
Power Dissipation	0.5W

Note:

Stresses greater than those listed under MAXIMUM RATINGS may cause permanent damage to the device. This is a stress rating only and functional operation of the device at these or any other conditions above those indicated in the operational sections of this specification is not implied. Exposure to absolute maximum rating conditions for extended periods may affect reliability.

DC Electrical Characteristics (Over the Operating Range, $T_A = -40^\circ\text{C}$ to $+85^\circ\text{C}$, $V_{CC} = 3.0$ to 3.6V)

Parameters	Description	Test Conditions ⁽¹⁾	Min.	Typ. ⁽²⁾	Max.	Units
V _{IH}	Input HIGH Voltage	S1, S2	2.0	—	—	V
V _{IL}	Input LOW Voltage	S1, S2	-0.5	—	0.8	V
I _{IH}	Input HIGH Current	$V_{CC} = \text{MAX.}, V_{IN} = V_{CC}$	—	—	±1	µA
I _{IL}	Input LOW Current	$V_{CC} = \text{MAX.}, V_{IN} = \text{GND}$	—	—	±1	µA
R _{ON}	Switch On Resistance	$V_{CC} = \text{Min.}, V_{IN} = 0.0\text{V},$ $I_{ON} = 24\text{mA}$	—	5	8	Ω
R _{ON}	Switch On Resistance	$V_{CC} = \text{Min.}, V_{IN} = 2.4\text{V},$ $I_{ON} = 12\text{mA}$	—	10	15	Ω
C _{IN}	Input Capacitance	$V_{IN} = 0\text{V}, 25^\circ\text{C}, f = 1\text{ MHz}$			3.0	pF
C _{ON}	A/B Capacitance	$V_{IN} = 0\text{V}, 25^\circ\text{C}, f = 1\text{ MHz}$			25.0	pF
I _{CC}	Power Supply Quiescent	$V_{CC} = \text{Max.}, V_{IN} = \text{GND or } V_{CC}$	—	—	10	µA
I _{OZH}	High Impedance Output Current	$0 \leq A, B \leq V_{CC}$			±1	µA
V _{IK}	Clamp Diode Voltage	$V_{CC} = \text{Min.}, I_{IN} = -18\text{mA}$		-0.7	-1.2	V

Note: 1. Typical values are shown at $V_{CC} = 3.3\text{V}$, $+25^\circ\text{C}$ ambient and maximum loading.

PI3B16248 Electrical Characteristics ($V_{CC} = 3.0\text{V}$ to 3.6V , $T_A = -40^\circ\text{C}$ to $+85^\circ\text{C}$)

Parameters	Description	Test Conditions	PI3B16248			
			Com.			
			Min.	Max.	Units	
t _{PLH}	Propagation Delay A _x to xB _x	$C_L = 50\text{pF}$ $R_L = 500\Omega$	16248	—	250	ps
t _{EN} ⁽³⁾	Bus Enable	$C_L = 50\text{pF}$ $R_L = 500\Omega$ $R = 500\Omega$		1	4.5	ns
t _{DIS} ⁽³⁾	Bus Disable			1	5.0	
t _M	Make-before-break time			0	2	

Notes:

1. This parameter is guaranteed but not tested on Propagation Delays.
2. The bus switch contributes no propagational delay other than the RC delay of the ON resistance of the switch and the load capacitance. The time constant for the switch alone is of the order of 0.25ns for 50pF load. Since this time constant is much smaller than the rise/fall times of typical driving signals, it adds very little propagational delay to the system. Propagational delay of the bus switch when used in a system is determined by the driving circuit on the driving side of the switch and its interaction with the load on the driven side.
3. See test circuit and waveforms.