

Product Features:

- Near zero propagation delay
- 5Ω switches connect inputs to outputs when enabled
- Direct bus connection when switches are ON
- Ultra Low Quiescent Power (0.2μA Typical)
 - Ideally suited for notebook applications
- Pin compatible with 74 Series 244 logic devices
- Packages available:
 - 20-pin 173 mil wide plastic TSSOP (L)
 - 20-pin 300 mil wide plastic DIP (P)
 - 20-pin 150 mil wide plastic QSOP (Q)
 - 20-pin 300 +mil wide plastic SOIC (S)

Product Description:

Pericom Semiconductor's PI5C series of logic circuits are produced in the Company's advanced 0.8 micron CMOS technology, achieving industry leading performance.

The PI5C3244 features a set of eight bus switches which is pinout and function compatible with the PI74FCT244T, 74F244, and 74ALS/AS/LS 244 8-bit drivers. Two enable signals ($\overline{BE}n$) turn the switches on similar to the enable signals of the 244. The bus switch creates no additional propagation delay or ground bounce noise.

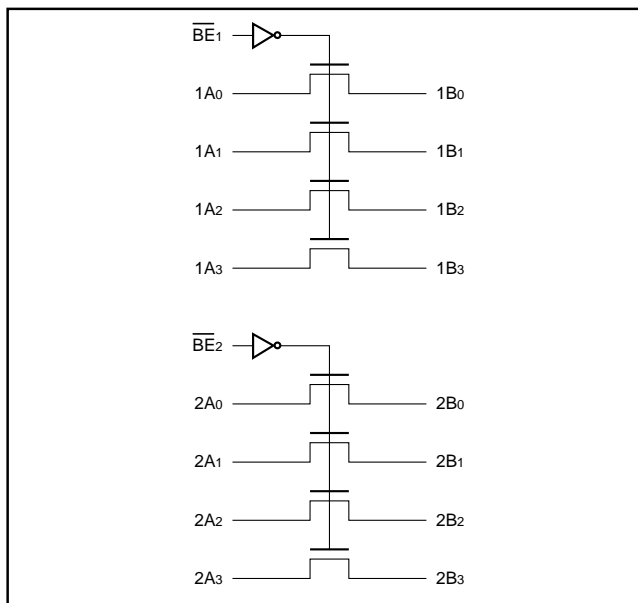
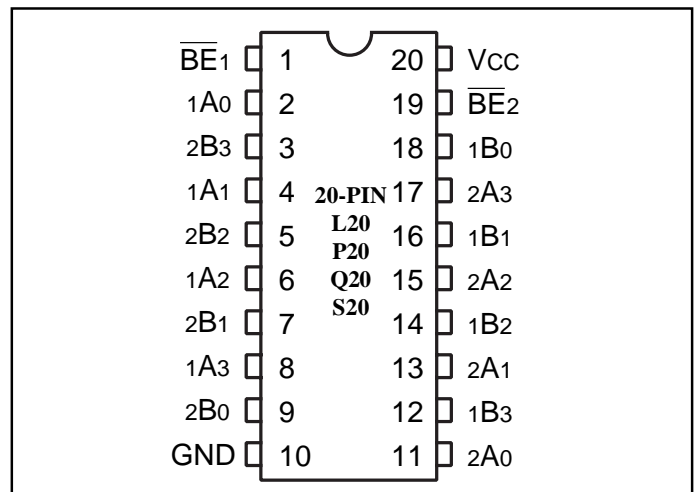
Logic Block Diagram

Product Pin Configuration

Truth Table⁽¹⁾

$\overline{BE}1$	$\overline{BE}2$	1A, 1B	2A, 2B
H	H	Disconnect	Disconnect
L	H	1A = 1B	Disconnect
H	L	Disconnect	2A = 2B
L	L	1A = 1B	2A = 2B

Note: 1. H = High Voltage Level
L = Low Voltage Level

Product Pin Description

Pin Name	Description
$\overline{BE}n$	Bus Output Enable (Active LOW)
A0-A3	Bus A
B0-B3	Bus B
GND	Ground
Vcc	Power

Maximum Ratings

(Above which the useful life may be impaired. For user guidelines, not tested.)

Storage Temperature	-65°C to +150°C
Ambient Temperature with Power Applied	-40°C to +85°C
Supply Voltage to Ground Potential (Inputs & Vcc Only)	-0.5V to +7.0V
Supply Voltage to Ground Potential (Outputs & D/O Only)	-0.5V to +7.0V
DC Input Voltage	-0.5V to +7.0V
DC Output Current	120 mA
Power Dissipation	0.5W

Note:

Stresses greater than those listed under MAXIMUM RATINGS may cause permanent damage to the device. This is a stress rating only and functional operation of the device at these or any other conditions above those indicated in the operational sections of this specification is not implied. Exposure to absolute maximum rating conditions for extended periods may affect reliability.

DC Electrical Characteristics (Over the Operating Range, TA = -40°C to +85°C, VCC = 5V ±5%)

Parameters	Description	Test Conditions ⁽¹⁾	Min.	Typ ⁽²⁾	Max.	Units
V _{IH}	Input HIGH Voltage	Guaranteed Logic HIGH Level	2.0			V
V _{IL}	Input LOW Voltage	Guaranteed Logic LOW Level	-0.5		0.8	V
I _{IH}	Input HIGH Current	V _{CC} = Max., V _{IN} = V _{CC}			±1	µA
I _{IL}	Input LOW Current	V _{CC} = Max., V _{IN} = GND			±1	µA
I _{OZH}	High Impedance Output Current	0 ≤ A, B ≤ V _{CC}			±1	µA
V _{IK}	Clamp Diode Voltage	V _{CC} = Min., I _{IN} = -18 mA		-0.7	-1.2	V
I _{OS}	Short Circuit Current ⁽³⁾	A (B) = 0V, B (A) = V _{CC}	100			mA
V _H	Input Hysteresis at Control Pins			150		mV
R _{ON}	Switch On Resistance ⁽⁴⁾	V _{CC} = Min., V _{IN} = 0.0V, I _{ON} = 48 mA V _{CC} = Min., V _{IN} = 2.4V, I _{ON} = 15 mA		5 10	7 15	Ω

Capacitance (TA = 25°C, f = 1 MHz)

Parameters ⁽⁵⁾	Description	Test Conditions	Typ	Max.	Units
C _{IN}	Input Capacitance	V _{IN} = 0V		6	pF
C _{OFF}	A/B Capacitance, Switch Off	V _{IN} = 0V		6	pF
C _{ON}	A/B Capacitance, Switch On	V _{IN} = 0V		8	pF

Notes:

1. For Max. or Min. conditions, use appropriate value specified under Electrical Characteristics for the applicable device type.
2. Typical values are at V_{CC} = 5.0V, T_A = 25°C ambient and maximum loading.
3. Not more than one output should be shorted at one time. Duration of the test should not exceed one second.
4. Measured by the voltage drop between A and B pin at indicated current through the switch. ON resistance is determined by the lower of the voltages on the two (A,B) pins.
5. This parameter is determined by device characterization but is not production tested.

Power Supply Characteristics

Parameters	Description	Test Conditions ⁽¹⁾		Min.	Typ ⁽²⁾	Max.	Units
I _{CC}	Quiescent Power Supply Current	V _{CC} =Max.	V _{IN} =GND or V _{CC}		0.1	3.0	μA
ΔI _{CC}	Supply Current per Input @ TTL HIGH	V _{CC} =Max.	V _{IN} =3.4V ⁽³⁾			2.5	mA
I _{CCD}	Supply Current per Input per MHz ⁽⁴⁾	V _{CC} =Max., A and B Pins Open BE1 or BE2=GND Control Input Toggling 50% Duty Cycle				0.25	mA/ MHz

Notes:

- For conditions shown as Max. or Min., use appropriate value specified under Electrical Characteristics for the applicable device.
- Typical values are at V_{CC} = 5.0V, +25°C ambient.
- Per TTL driven input (V_{IN} = 3.4V, control inputs only); A and B pins do not contribute to I_{CC}.
- This current applies to the control inputs only and represent the current required to switch internal capacitance at the specified frequency. The A and B inputs generate no significant AC or DC currents as they transition. This parameter is not tested, but is guaranteed by design.

Switching Characteristics over Operating Range

Parameters	Description	Conditions ⁽¹⁾	PI5C3244		Unit	
			Com.			
			Min	Max		
t _{PLH} t _{PHL}	Propagation Delay ^(2,3) A _X to B _X	C _L = 50 pF R _L = 500 Ω		0.25	ns	
t _{PZH} t _{PZL}	Bus Enable Time BE _X to A _X or B _X		1.5	5.6		ns
t _{PHZ} t _{PLZ}	Bus Disable Time BE _X to A _X or B _X		1.5	5.2		

Notes:

- See test circuit and wave forms.
- This parameter is guaranteed but not tested on Propagation Delays.
- The bus switch contributes no propagational delay other than the RC delay of the ON resistance of the switch and the load capacitance. The time constant for the switch alone is of the order of 0.25 ns for 50 pF load. Since this time constant is much smaller than the rise/fall times of typical driving signals, it adds very little propagational delay to the system. Propagational delay of the bus switch when used in a system is determined by the driving circuit on the driving side of the switch and its interaction with the load on the driven side.