



## PI5C3257C

### Quad 2:1 Mux/Demux BusSwitch with -2V Undershoot Protection

#### Product Features

- Near zero propagation delay
- 5ohms switches connect inputs to outputs
- Direct bus connection when switches are ON
- Undershoot Protection to -2V (Data Inputs Only)
- Pin compatible with 74 series 257 logic devices
- Packages available:
  - 16-pin 150 mil wide plastic QSOP (Q)
  - 16-pin 173 mil wide plastic TSSOP (L)

#### Product Description

Pericom Semiconductor's PI5C series of logic circuits are produced using the Company's advanced submicron CMOS technology, achieving industry leading performance.

The PI5C3257C is a Quad 2:1 multiplexer/demultiplexer with three-state outputs that is pinout and function compatible with the PI74FCT257T. Inputs can be connected to outputs with low on resistance (5ohms) with no additional ground bounce noise or propagation delay.

#### Logic Block Diagram

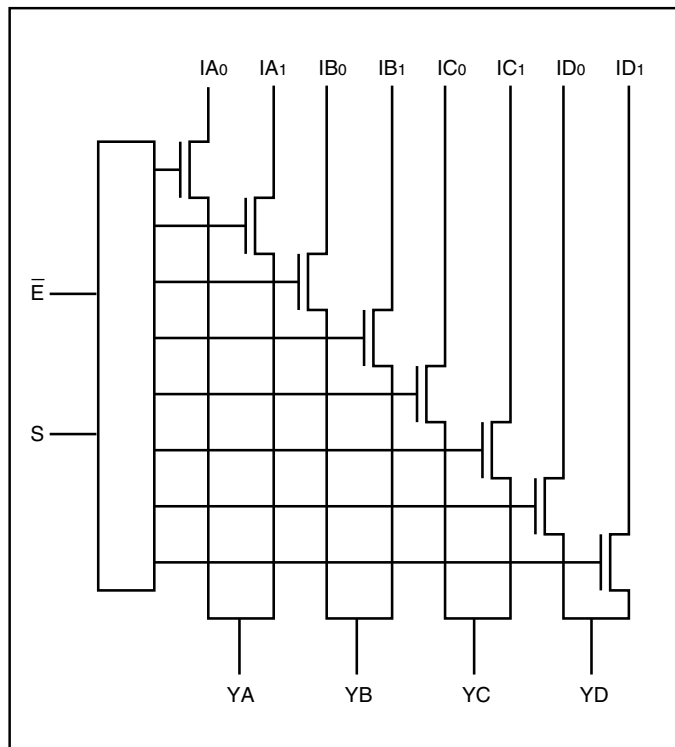

#### 16-Pin Product Configuration

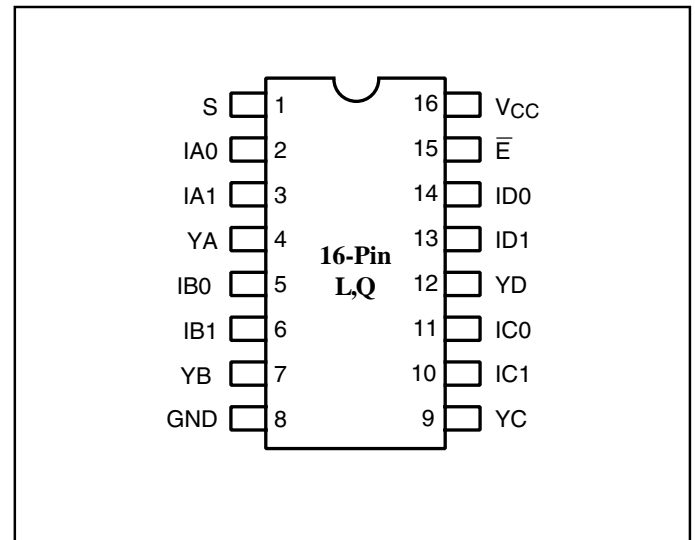

#### Truth Table<sup>(1)</sup>

$\bar{E}$	S	YA	YB	YC	YD	Function
H	X	Hi-Z	Hi-Z	Hi-Z	Hi-Z	Disable
L	L	IA0	IB0	IC0	ID0	S = 0
L	H	IA1	IB1	IC1	ID1	S = 1

#### Product Pin Description

Pin Name	Description
IAN-IDN	Data Inputs
S	Select Inputs
$\bar{E}$	Enable
YA-YD	Data Outputs
GND	Ground
Vcc	Power
NC	No Connect

Note: 1. H = High Voltage Level  
L = Low Voltage Level



**Maximum Ratings**

(Above which the useful life may be impaired. For user guidelines, not tested.)

Storage Temperature .....	-65°C to +150°C
Ambient Temperature with Power Applied .....	-40°C to +85°C
Supply Voltage to Ground Potential (Inputs & V <sub>CC</sub> Only) .....	-0.5V to +7.0V
Supply Voltage to Ground Potential (Outputs & D/O Only) ....	-0.5V to +7.0V
DC Input Voltage .....	-0.5V to +7.0V
DC Output Current .....	120mA
Power Dissipation .....	0.5W

**Note:**

Stresses greater than those listed under MAXIMUM RATINGS may cause permanent damage to the device. This is a stress rating only and functional operation of the device at these or any other conditions above those indicated in the operational sections of this specification is not implied. Exposure to absolute maximum rating conditions for extended periods may affect reliability.

**DC Electrical Characteristics** (Over the Operating Range, T<sub>A</sub> = -40°C to +85°C, V<sub>CC</sub> = 5V ±5%)

Parameters	Description	Test Conditions <sup>(1)</sup>	Min.	Typ <sup>(2)</sup>	Max.	Units
V <sub>IH</sub>	Input HIGH Voltage	Guaranteed Logic HIGH Level	2.0			V
V <sub>IL</sub>	Input LOW Voltage	Guaranteed Logic LOW Level	-0.5		0.8	V
I <sub>IH</sub>	Input HIGH Current	V <sub>CC</sub> = Max., V <sub>IN</sub> = V <sub>CC</sub>			±1	μA
I <sub>IL</sub>	Input LOW Current	V <sub>CC</sub> = Max., V <sub>IN</sub> = GND			±1	μA
I <sub>OZH</sub>	High Impedance Output Current	0 ≤ I, Y ≤ V <sub>CC</sub>			±1	μA
V <sub>IK</sub>	Clamp Diode Voltage	V <sub>CC</sub> = Min., I <sub>IN</sub> = -18mA			-1.8	V
V <sub>UP</sub>	Undershoot Protection Voltage <sup>(3)</sup>	Max Inputs, Undershoot Pulse Duration <25ns			-2.0	V
R <sub>ON</sub>	Switch On Resistance <sup>(4)</sup>	V <sub>CC</sub> = Min., V <sub>IN</sub> = 0.0V, I <sub>ON</sub> = 48mA V <sub>CC</sub> = Min., V <sub>IN</sub> = 2.4V, I <sub>ON</sub> = 15mA		4 8	7 15	ohms

**Capacitance** (T<sub>A</sub> = 25°C, f = 1 MHz)

Parameters <sup>(5)</sup>	Description	Test Conditions	Typ	Max.	Units
C <sub>IN</sub>	Input Capacitance	V <sub>IN</sub> = 0V		6	pF
C <sub>OFF</sub>	I <sub>N</sub> /Y <sub>N</sub> Capacitance, Switch Off	V <sub>IN</sub> = 0V		6	pF
C <sub>ON</sub>	I <sub>N</sub> /Y <sub>N</sub> Capacitance, Switch On	V <sub>IN</sub> = 0V		14	pF

**Notes:**

1. For Max. or Min. conditions, use appropriate value specified under Electrical Characteristics for the applicable device type.
2. Typical values are at V<sub>CC</sub> = 5.0V, T<sub>A</sub> = 25°C ambient and maximum loading.
3. On 1AN and 1B<sub>IN</sub> (Data Input) pins only.
4. Measured by the voltage drop between I and Y pin at indicated current through the switch. ON resistance is determined by the lower of the voltages on the two (I,Y) pins.
5. This parameter is determined by device characterization but is not production tested.

### Power Supply Characteristics

Parameters	Description	Test Conditions <sup>(1)</sup>		Min.	Typ <sup>(2)</sup>	Max.	Units
I <sub>CC</sub>	Quiescent Power Supply Current	V <sub>CC</sub> = Max.	V <sub>IN</sub> = GND or V <sub>CC</sub>			100	μA
ΔI <sub>CC</sub>	Supply Current per Input @ TTL HIGH	V <sub>CC</sub> = Max.	V <sub>IN</sub> = 3.4V <sup>(3)</sup>			2.5	mA

**Notes:**

1. For Max. or Min. conditions, use appropriate value specified under Electrical Characteristics for the applicable device.
2. Typical values are at V<sub>CC</sub> = 5.0V, +25°C ambient.
3. Per TTL driven input (V<sub>IN</sub> = 3.4V, control inputs only); I and Y pins do not contribute to I<sub>CC</sub>.

### Switching Characteristics over Operating Range

Parameters	Description	Conditions <sup>(1)</sup>	PI5C3257C		Units
			Com.		
			Min	Max	
t <sub>IY</sub>	Propagation Delay <sup>(2,3)</sup> I <sub>N</sub> to Y <sub>N</sub>	C <sub>L</sub> = 50pF R <sub>L</sub> = 500ohms		0.25	ns
t <sub>SY</sub>	Bus Select Time S <sub>N</sub> to Y <sub>N</sub>		7.0	30.0	
t <sub>PZH</sub> t <sub>PZL</sub>	Bus Disable Time E̅ to Y <sub>N</sub>		7.0	30.0	
t <sub>PHZ</sub> t <sub>PLZ</sub>	Bus Disable Time E̅ to Y <sub>N</sub>		1.5	8.8	

**Notes:**

1. See test circuit and waveforms.
2. This parameter is guaranteed but not tested on Propagation Delays.
3. The bus switch contributes no propagational delay other than the RC delay of the ON resistance of the switch and the load capacitance. The time constant for the switch alone is of the order of 0.25ns for 50pF load. Since this time constant is much smaller than the rise/fall times of typical driving signals, it adds very little propagational delay to the system. Propagational delay of the bus switch when used in a system is determined by the driving circuit on the driving side of the switch and its interaction with the load on the driven side.

### Applications Information

#### Logic Inputs

The logic control inputs can be driven up to +5.5V regardless of the supply voltage. For example, given a 5.0V supply, the control or select pins may be driven low to 0V and high to 5.5V. Driving the control or select pins Rail-toRail<sup>®</sup> minimizes power consumption.

#### Power -Supply Sequencing

Proper power-supply sequencing is recommended for all CMOS devices. Always apply V<sub>CC</sub> before applying signals to the input/output or control pins.

### 16 - TSSOP (L) Package Mechanical

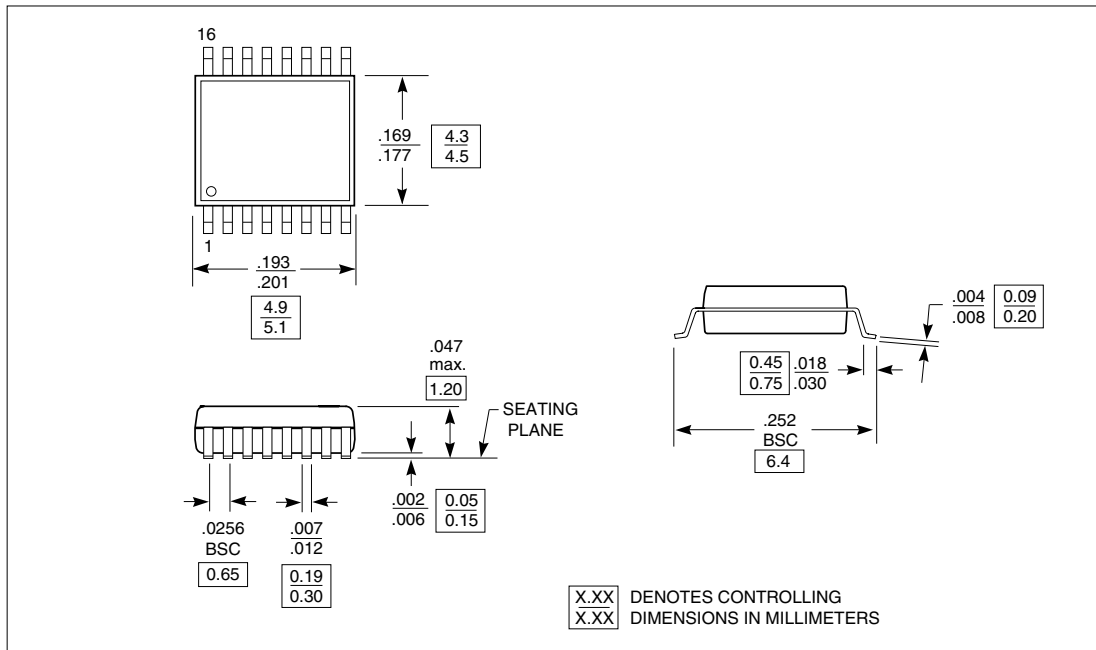

### 16 - QSOP (Q) Package Mechanical

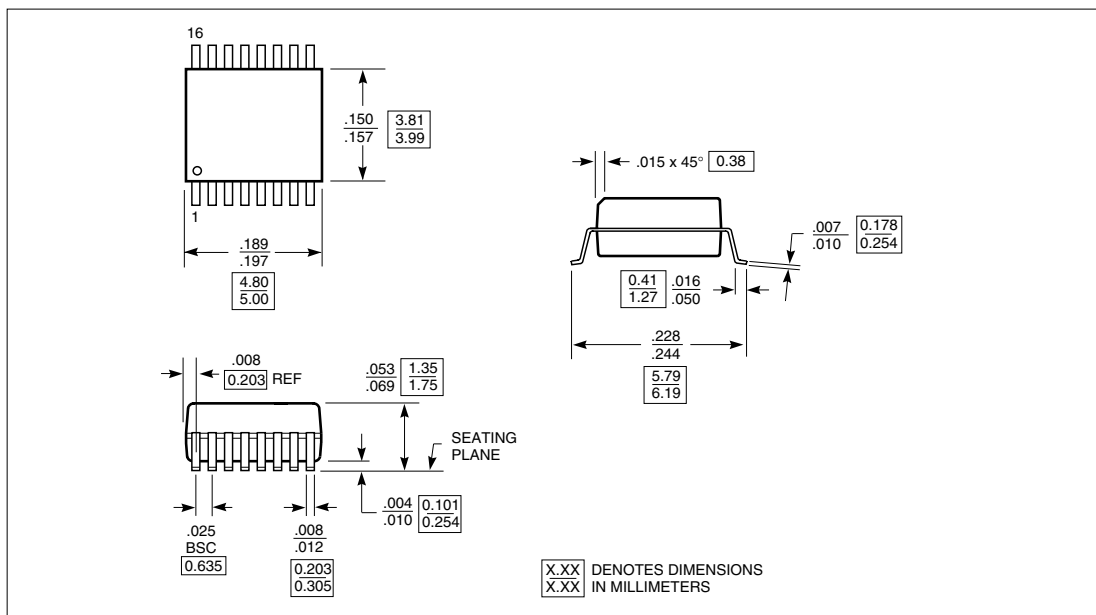

### Ordering Information

Part	Pin-Package	Temperature
PI5C3257CL	16 TSSOP (L)	-40°C to +85°C
PI5C3257CQ	16 QSOP (Q)	-40°C to +85°C

**Pericom Semiconductor Corporation**

2380 Bering Drive • San Jose, CA 95131 • 1-800-435-2336 • Fax (408) 435-1100 • <http://www.pericom.com>