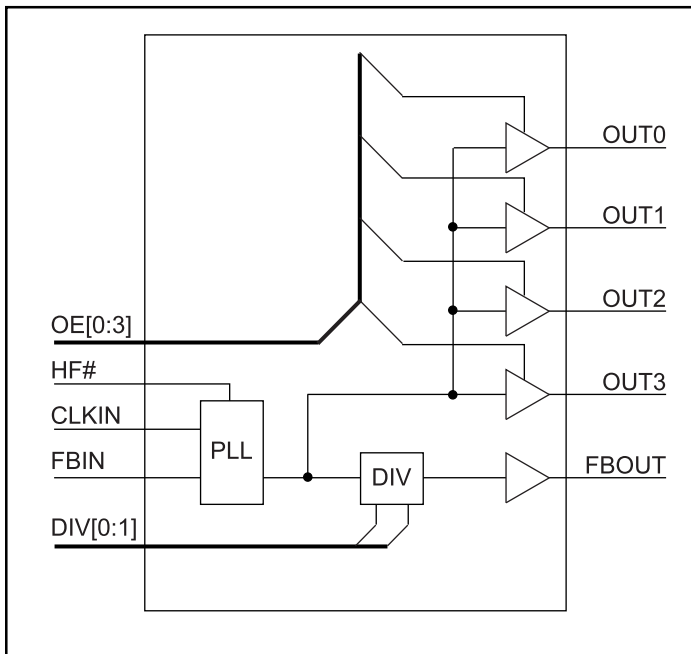
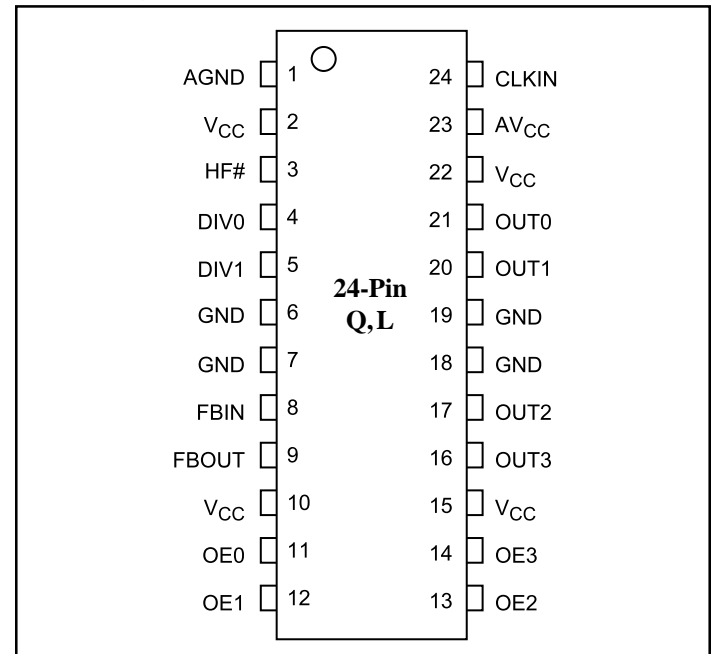

**Product Features**

- Four synchronous outputs
- Selectable divider/multiplier
- Output Enable control
- Low phase error < 150 ps
- Allows clock input to have spread spectrum modulation for EMI reduction
- Low output skew < 200 ps
- Low cycle jitter < 200 ps
- Industrial temperature (−40° C to 85° C)
- 3.3V V supply
- Packages: 24-pin QSOP (Q) and 24-pin TSSOP (L)

**Product Description**

PI6C2310 is a low skew, low jitter, PLL clock buffer with divider or multiplier designed for PCI-X application in servers and workstations. There are two selectable input ranges using HF# input: 10-40 MHz and 40-80 MHz. All outputs are synchronized to the input and to the other outputs. Each output can be independently turned off to reduce EMI and power consumption.

**Block Diagram**

**Pin Configuration**

**Clock Select Table**

HF#	DIV1	DIV0	OUTx	CLKIN	OUTx
1	1	1	CLKIN	33MHz	33MHz
1	1	0	2xCLKIN		66MHz
1	0	1	3xCLKIN		100MHz
1	0	0	4xCLKIN		133MHz
0	1	1	CLKIN/2	66MHz	33MHz
0	1	0	CLKIN		66MHz
0	0	1	1.5xCLKIN		100MHz
0	0	0	2xCLKIN		133MHz

**Pin Description**

Pin	Type	Qty	Symbol	Description
16,17,20,21	O	4	OUT[0:3]	Clock outputs. To achieve zero input to output delay, all outputs must have the same loading.
11-14	I	4	OE[0:3]	Active high Output Enable, pulled up. When OE is low, OUT [0:3] outputs are disabled at low state.
9	O	1	FBOUT	Feedback output. To achieve zero input to output delay, FBOUT must have the same loading as OUT[0:3].
8	I	1	FBIN	Feedback input. 7pF must be added to the output driving this pin (FBOUT) in addition to the other load.
24	I	1	CLKIN	Input Clock.
3	I	1	HF#	High Frequency range, pulled up. "1" = Low, "0" = High.
4,5	I	2	DIV[0,1]	Divider/Multiplier Select, pulled up.
2,10,15,22	P	4	V <sub>CC</sub>	3.3V power
6,7,18,19	P	4	GND	Ground
23	P	1	AV <sub>CC</sub>	3.3V analog power
1	P	1	AGND	Analog ground

**Absolute Maximum Ratings**

Supply Voltage (V <sub>CC</sub> , AV <sub>CC</sub> ) .....	0.5V to +7.0V
Input Voltage .....	-0.5V to V <sub>CC</sub> +0.5V
Industrial Operating Temperature .....	-40°C to +85°C
Storage Temperature .....	-65°C to +150°C
Junction Temperature .....	150°C
Input ESD MIL-883, Method 3015, human body model .....	2kV

**Operating Condition**

Symbol	Description	Min.	Max.	Units
V <sub>CC</sub> , AV <sub>CC</sub>	I/O Supply, Analog Core Supply	3.0	3.6	V
T <sub>a</sub>	Industrial Ambient Temperature	-40	+85	°C

**DC Electrical Characteristics Over Operating Conditions**

Symbol	Parameter	Conditions	Min.	Typ.	Max.	Units
V <sub>il</sub>	Low Input Voltage				0.8	V
V <sub>ih</sub>	High Input Voltage		2.0			
I <sub>il</sub>	Low Input Current	V <sub>IN</sub> = 0V			50	uA
I <sub>ih</sub>	High Input Current	V <sub>IN</sub> = V <sub>CC</sub>			200	
V <sub>ol</sub>	Low Output Voltage	V <sub>CC</sub> = 3.0V, I <sub>ol</sub> = 12mA			0.4	V
V <sub>oh</sub>	High Output Voltage	V <sub>CC</sub> = 3.0V, I <sub>oh</sub> = -12mA	2.4			
I <sub>dd_33</sub>	Supply Current	C <sub>1</sub> = 15pF, F <sub>OUT</sub> = 33MHz		25	tbd	mA
I <sub>dd_66</sub>	Supply Current	C <sub>1</sub> = 15pF, F <sub>OUT</sub> = 66MHz		35		
I <sub>dd_100</sub>	Supply Current	C <sub>1</sub> = 15pF, F <sub>OUT</sub> = 100MHz		45		
I <sub>dd_133</sub>	Supply Current	C <sub>1</sub> = 15pF, F <sub>OUT</sub> = 133MHz		60		
C <sub>o</sub>	Output Capacitance				6	pF
C <sub>i</sub>	Input Capacitance				5	
C <sub>l</sub>	Load Capacitance				15	
L <sub>pin</sub>	Pin Inductance				7	nH

**Switching Characteristics (T<sub>A</sub> = 25°C, V<sub>CC</sub> = 3.3V ± 0.3V, C<sub>1</sub> = 15pF, F<sub>OUT</sub> = 66.67 MHz)**

Symbol	Parameter	Test Conditions	Min.	Typ.	Max.	Units
F <sub>in</sub>	Input frequency	Low Freq., HF# = "1"	10	33	40	MHz
		High Freq., HF# = "0"	40	66	80	
T <sub>pd</sub>	Propagation delay	CLKIN to FBIN rising edges @ V <sub>DD</sub> /2	-150		150	ps
T <sub>sk</sub>	Output skew	@ 1.4V, rising edges			200	
T <sub>skpp</sub>	Pkg to pkg skew	@ V <sub>DD</sub> /2, rising edges, same CLKIN			400	
T <sub>jc</sub>	Cycle jitter				200	
T <sub>dc</sub>	Duty cycle	@ 1.4V	45	50	55	%
T <sub>r</sub> /T <sub>f</sub>	Rise/Fall time	0.8V~2.0V			1.5	ns

**Note:** T<sub>jc</sub> = T<sub>p</sub>(n+1) - T<sub>p</sub>(n)      T<sub>dc</sub> = T<sub>h</sub>/T<sub>p</sub>  
T<sub>p</sub>(n) = Period of the n<sup>th</sup> cycle      T<sub>p</sub> = Period cycle time  
T<sub>p</sub>(n+1) = Period of n<sup>th</sup>+1 cycle      T<sub>h</sub> = High time @ 1.4V

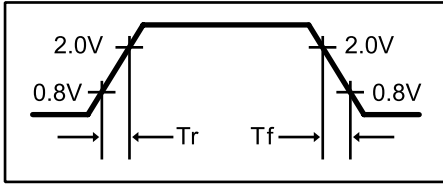

Figure 1. Rise/Fall time

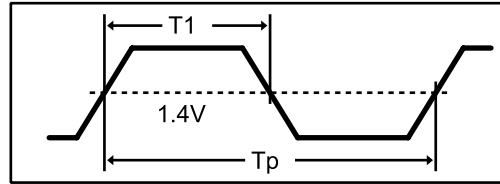

Figure 2. Duty cycle

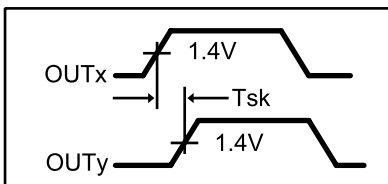

Figure 3. Output skew

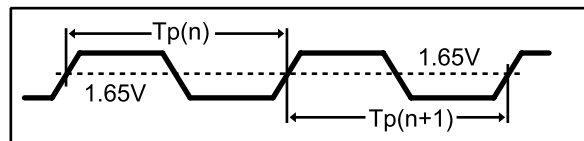

Figure 4. Cycle jitter

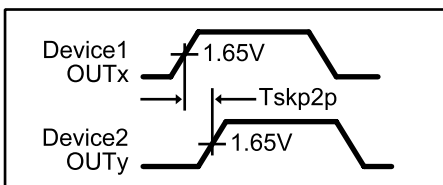

Figure 5. Pkg.-to-Pkg. skew

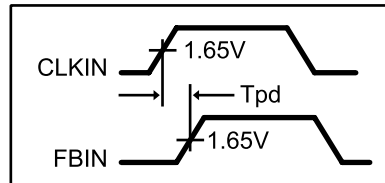

Figure 6. Propagation Delay

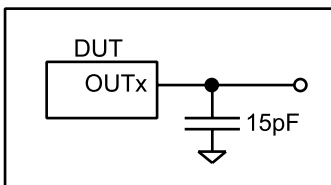
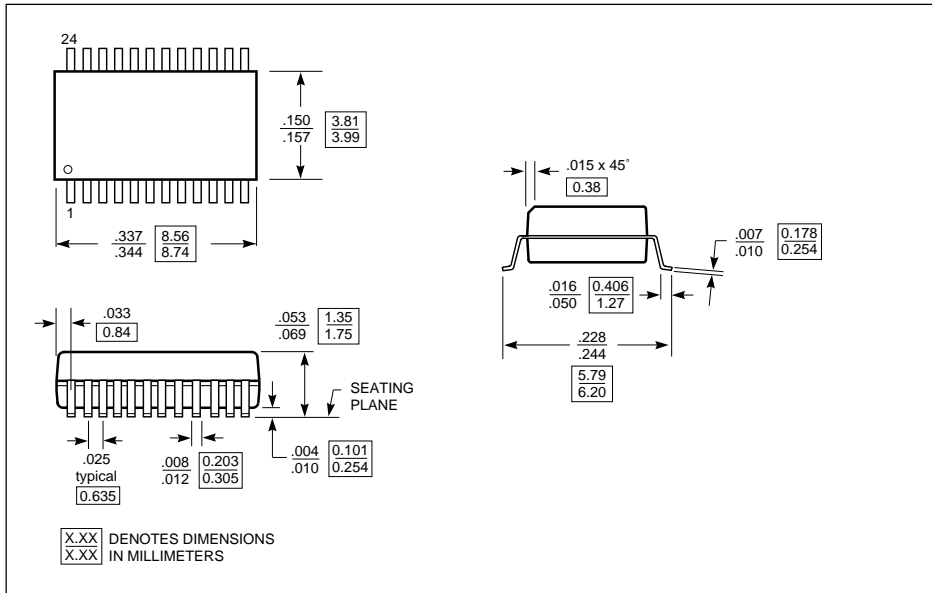
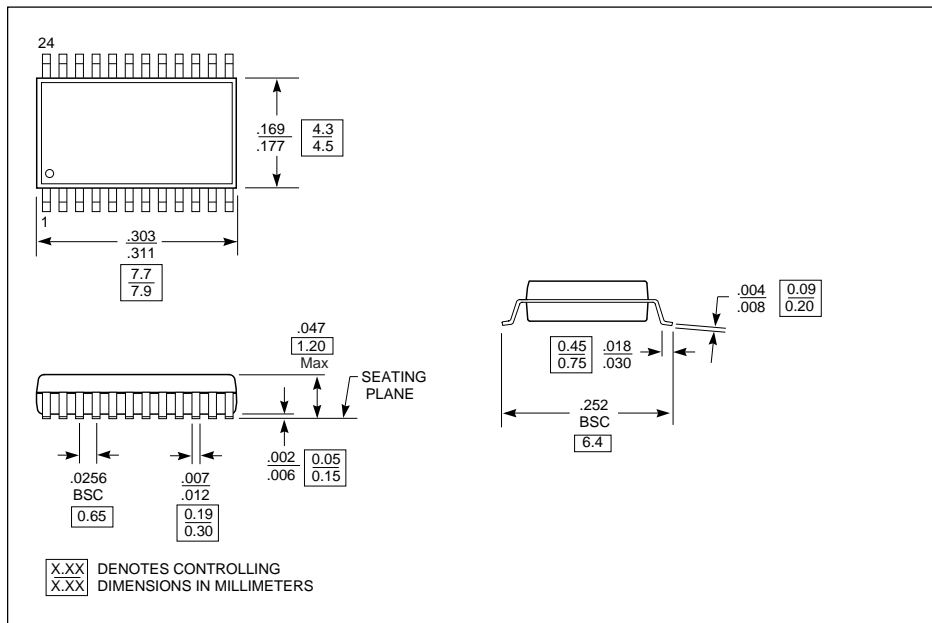

Figure 7. Test load

**Packaging Mechanical: 24-pin QSOP (Q)**



**Packaging Mechanical: 24-Pin TSSOP (L)**



**Ordering Information**

Ordering Code	Package Name	Package Type	Operating Temp
PI6C2310Q	Q24	24-pin, 150-mil QSOP	Industrial
PI6C2310L	L24	24-pin, 4.4-mil TSSOP	