



PI6C991

5V High-Speed Programmable Skew Clock Buffer - *SuperClock*[®]

Product Features

- Four pairs of programmable skew outputs
- 3.75 to 80 MHz output operation
- User-selectable output functions:
 - Selectable skews
 - Inverted and noninverted
 - Operation at ½ and ¼ input frequency
 - Operation at 2X and 4X input frequency
- Low skew <100ps typical, same pair. 250ps max.
- Allow REF clock input to have Spread Spectrum modulation for EMI reduction
- 2X, 4X, ½ and ¼ outputs
- 3-level inputs for skew and output frequency control
- External feedback, internal loop filter
- Low cycle-to-cycle Jitter: <25ps RMS
- Duty cycle of output clock signals: 45% min. 55% max.
- Compatible with Pentium based processor
- Same pinout as Cypress CY7B991
- Packaged in Plastic 32-pin PLCC Package

Description

The PI6C991 is a low-skew, low jitter, 5V phase-lock loop (PLL) programmable skew clock driver, for high performance computing and networking applications. This part offers user selectable skew-control of 4 output pairs, providing the timing delays necessary to optimize high performance clock distribution circuits.

Each output can be hardwired to one of nine delay or function configurations. Delay increments are determined by the input clock frequency and the configurations selected by the user.

The PI6C991 allows the REF clock input to have Spread Spectrum modulation for EMI reduction.

The PI6C991 is pin-compatible with Cypress RoboClock CY7B991, with improved AC/DC characteristics.

Logic Block Diagram

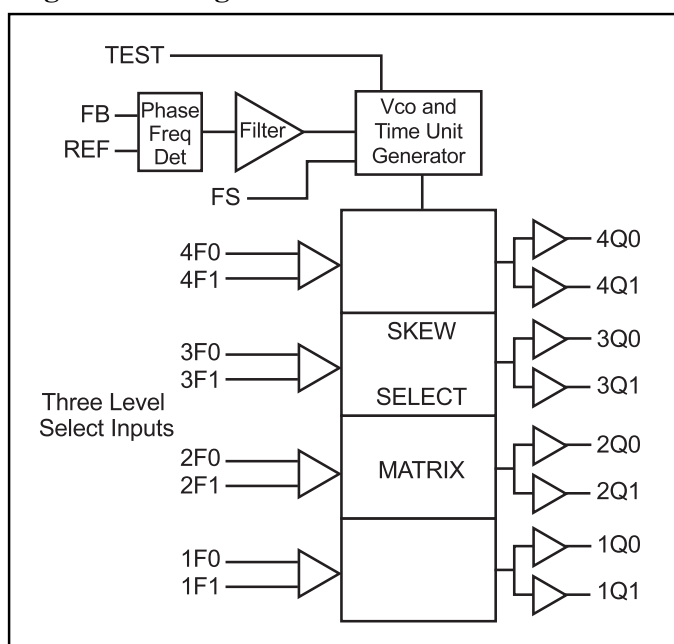

Pin Configuration

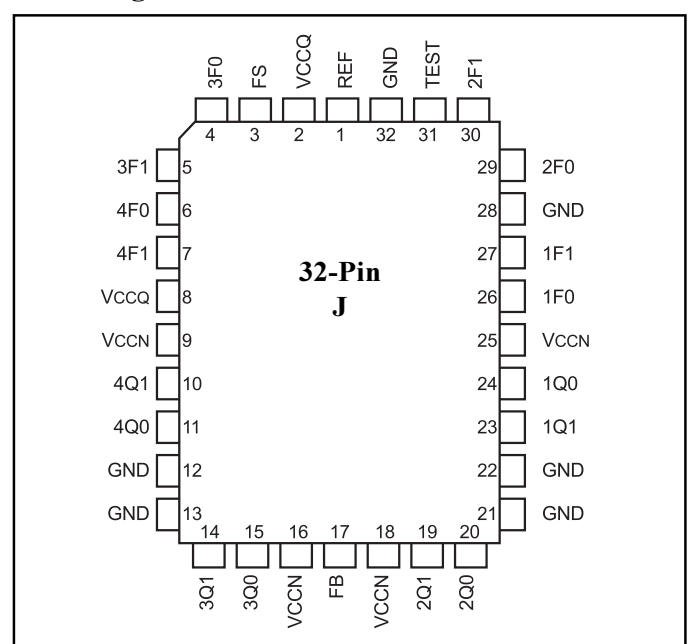

Pin Definitions

Signal Name	I/O	Description
REF	I	Reference frequency input. This input supplies the frequency and timing reference which all functional variation is measured.
FB		PLL feedback input (typically connected to one of the eight outputs).
FS		Three-level frequency range select. See Table 1.
1F0, 1F1		Three-level function select inputs for output pair 1 (1Q0, 1Q1). See Table 2.
2F0, 2F1		Three-level function select inputs for output pair 2 (2Q0, 2Q1). See Table 2.
3F0, 3F1		Three-level function select inputs for output pair 3 (3Q0, 3Q1). See Table 2.
4F0, 4F1		Three-level function select inputs for output pair 4 (4Q0, 4Q1). See Table 2.
TEST		Three-level select. See test mode section under the block diagram descriptions.
1Q0, 1Q1	O	Output pair 1. See Table 2.
2Q0, 2Q1		Output pair 2. See Table 2.
3Q0, 3Q1		Output pair 3. See Table 2.
4Q0, 4Q1		Output pair 4. See Table 2.
V _{CCN}	PWR	Power supply for output drivers.
V _{CCQ}		Power supply for internal circuitry.
GND		Ground

Block Diagram Description

Phase Frequency Detector and Filter

These two blocks accept input signals from the reference frequency (REF) input and the feedback (FB) input and generate correction information to control the frequency of the Voltage-Controlled Oscillator (VCO). These blocks, along with the VCO, form a Phase-Locked Loop (PLL) that tracks the incoming REF signal.

VCO and Time Unit Generator

The VCO accepts analog control inputs from the PLL filter block and generates a frequency that is used by the time unit generator to create discrete time units that are selected in the skew mix matrix. The operational range of the VCO is determined by the FS control pin. The time unit (t_U) is determined by the operating frequency of the device and the level of the FS pin as shown in Table 1.

Skew Select Matrix

The skew select matrix is comprised of four independent sections. Each section has two low-skew, high-fanout drivers (xQ0, xQ1), and two corresponding three-level function select (xF0, xF1) inputs. Table 2 shows the nine possible output functions for each section as determined by the function select inputs. All times are measured with respect to the REF input assuming that the output connected to the FB input has $0t_U$ selected.



Table 1. Frequency Range Select and t_U Calculation⁽¹⁾

FS ^(2,3)	f _{NOM} (MHz)		$t_U = \frac{1}{f_{NOM} \times N}$ where N=	Approximate Frequency (MHz) at which $t_U = 1.0ns$
	Min.	Max.		
LOW	15	30	44	22.7
MID	25	50	26	38.5
HIGH	40	100	16	62.5

Table 2. Programmable Skew Configurations⁽¹⁾

Function Selects		Output Functions		
1F1, 2F1, 3F1, 4F1	1F0, 2F0, 3F0, 4F0	1Q0, 1Q1, 2Q0, 2Q1	3Q0, 3Q1	4Q0, 4Q1
LOW	LOW	-4t _U	Divide by 2	
	MID	-3t _U	-6t _U	
	HIGH	-2t _U	-4t _U	
MID	LOW	-1t _U	-2t _U	
	MID	-0t _U		
	HIGH	+1t _U	+2t _U	
HIGH	LOW	+2t _U	+4t _U	
	MID	+3t _U	+6t _U	
	HIGH	+4t _U	Divide by 4	Inverted

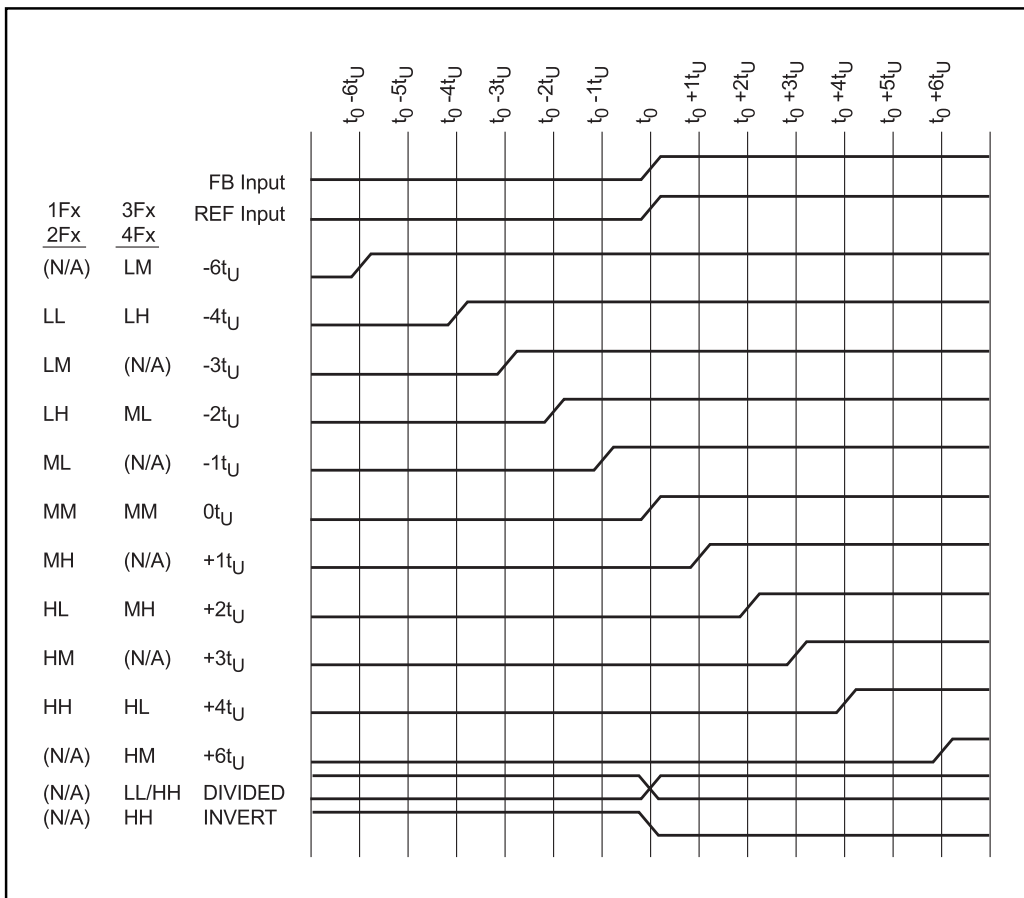

Figure 1. Typical Outputs with FB Connected to a Zero-Skew Output⁽⁴⁾



Test Mode

The TEST input is a three-level input. In normal system operation, this pin is connected to ground, allowing the PI6C991 to operate as explained briefly above (for testing purposes, any of the three-level inputs can have a removable jumper to ground, or be tied LOW through a 100Ω resistor. This will allow an external tester to change the state of these pins).

If the TEST input is forced to its MID or HIGH state, the device will operate with its internal phase locked loop disconnected, and input levels supplied to REF will directly control all outputs. Relative output to output functions are the same as in normal mode.

In contrast with normal operation (TEST tied LOW). All outputs will function based only on the connection of their own function select inputs (xF0 and xF1) and the waveform characteristics of the REF input.

Maximum Ratings

(Above which the useful life may be impaired)

Storage Temperature	-65°C to +150°C
Ambient Temperature	
with Power Applied	-55°C to +125°C
Supply Voltage to Ground Potential	-0.5V to +7.0V
DC Input Voltage	-0.5V to +7.0V
Output Current into Outputs (LOW)	64mA
Static Discharge Voltage	
(per MIL-STD-883, Method 3015)	>2001V
Latch-Up Current	>200mA

Operating Range

Range	Ambient Temperature	V _{CC}
Commercial	0°C to +70°C	5V ±10%
Industrial	-40°C to +85°C	5V ±10%

Notes for Tables on Pages 3 through 7:

1. For all three-state inputs, HIGH indicates a connection to V_{CC}, LOW indicates a connections to GND, and MID indicates an open connection. Internal termination circuitry holds an unconnected input to V_{CC}/2.
2. The level to be set on FS is determined by the “normal” operating frequency (f_{NOM}) of the V_{CO} and the Time Unit Generator (see Logic Block Diagram). Nominal frequency (f_{NOM}) always appears at IQ0 and the other outputs when they are operated in their undivided modes (see Table 2). The frequency appearing at the REF and FB inputs will be f_{NOM} when the output connected to FB is undivided. The frequency of the REF and FB inputs will be f_{NOM}/2 or f_{NOM}/4 when the part is configured for a frequency multiplication by using a divided output as the FB input.
3. When the FS pin is selected HIGH, the REF input must not transition upon power-up until V_{CC} has reached 2.8V.
4. FB connected to an output selected for “zero” skew (ie., xF1 = xF0 = MID).
6. These inputs are normally wired to V_{CC}, GND, or left unconnected (actual threshold voltages vary as a percentage of V_{CC}). Internal termination resistors holds unconnected inputs at V_{CC}/2. If these inputs are switched, the function and timing of the outputs may glitch and the PLL may require an additional t_{LOCK} time before all datasheet limits are achieved.
7. The part should be tested one output at a time, output shorted for less than one second, less than 10% duty cycle. Room temperature only.
11. Test measurement levels are TTL levels (1.5V to 1.5V). Test conditions assume signal transition times of 2ns or less and output loading as shown in the AC Test Loads and Waveforms unless otherwise specified.
12. Guaranteed by statistical correlation. Tested initially and after any design or process changes that may affect these parameters.
13. Skew is defined as the time between the earliest and the latest output transition among all outputs for which the same t_U delay has been selected when all are loaded with 30pF and terminated with 50Ω to 2.06V.
14. t_{SKEWPR} is defined as the skew between a pair of outputs (xQ0 and xQ1) when all eight outputs are selected for 0t_U.
15. t_{SKEW0} is defined as the skew between outputs when they are selected for 0t_U. Other outputs are divided or inverted but not shifted.
16. C_L = 0pF. For C_L = 30pF, t_{SKEW0} = 0.35ns
17. There are three classes of outputs: Nominal (multiple of t_U delay), Inverted (4Q0 and 4Q1 only with 4F0 = 4F1 = HIGH), and Divided (3Qx and 4Qx only in Divide-by-2 or Divide-by-4 mode).
18. t_{DEV} is the output-to-output skew between any two devices operating under the same conditions (V_{CC} ambient temperature, air flow, etc.).
19. t_{ODCV} is the deviation of the output from a 50% duty cycle. Output pulse width variations are included in t_{SKEW2} and t_{SKEW4} specifications.
20. t_{PWH} is measured at 2.0V. t_{PWL} is measured at 0.8V.
21. t_{ORISE} and t_{OFALL} measured between 0.8V and 2.0V.
22. t_{LOCK} is the time that is required before synchronization is achieved. This specification is valid only after V_{CC} is stable and within normal operating limits. This parameter is measured from the application of a new signal or frequency at REF or FB until t_{PD} is within specified limits.



DC Characteristics Over the Operating Range

Symbol	Parameter	Test Condition	Min.	Max.	Units
V _{OH}	Output HIGH Voltage	V _{CC} = MIN, I _{OH} = -16mA	2.4		V
V _{OL}	Output LOW Voltage	V _{CC} = MIN, I _{OL} = 46mA		0.45	
V _{IH}	Input HIGH Voltage of REF, FB inputs		2.0	V _{CC}	
V _{IL}	Input LOW Voltage of REF, FB inputs		-0.5	0.8	
V _{IH3}	Input HIGH Voltage of 3-level inputs TEST, FS, xFn ⁽⁶⁾	MIN ≤ V _{CC} ≤ Max	V _{CC} - 0.85	V _{CC}	
V _{IM3}	Input MID Voltage of 3-level inputs TEST, FS, xFn ⁽⁶⁾		V _{CC} /2 - 0.5	V _{CC} /2 + 0.5	
V _{IL3}	Input LOW Voltage of 3-level inputs TEST, FS, xFn ⁽⁶⁾			0.85	
I _{IN}	Input Leakage Current of REF, FB inputs	V _{IN} = V _{CC} or 0.4V V _{CC} = Max		10	μA
I ₃	3-level Input DC Current (TEST, FS, nF1:0)	V _{IN} = V _{CC} (HIGH level)		200	
		V _{IN} = V _{CC} /2 (MID level)		50	
		V _{IN} = GND (LOW level)		200	
I _{OS}	Short Circuit Current ⁽⁷⁾	V _{CC} = Max, V _{OUT} = GND (25° only)		-250	mA
I _{CCQ}	Operating Current used by Internal Circuitry	V _{CCN} = V _{CCQ} = Max, All Input Selects Open		85	
I _{CCN}	Output Buffer Current per Output Pair	V _{CCN} = V _{CCQ} = Max, I _{OUT} = 0mA Input Selects Open, f _{MAX}		14	
PD	Power Dissipation per Output Pair			78	

Capacitance at REF and FB

Parameter	Description	Test Conditions	Max.	Units
C_{IN}	Input Capacitance	$T_A = 25^\circ\text{C}$, $f = 1\text{ MHz}$, $V_{CC} = 5.0\text{V}$	10	pF

AC Test Loads and Waveforms (PI6C991)

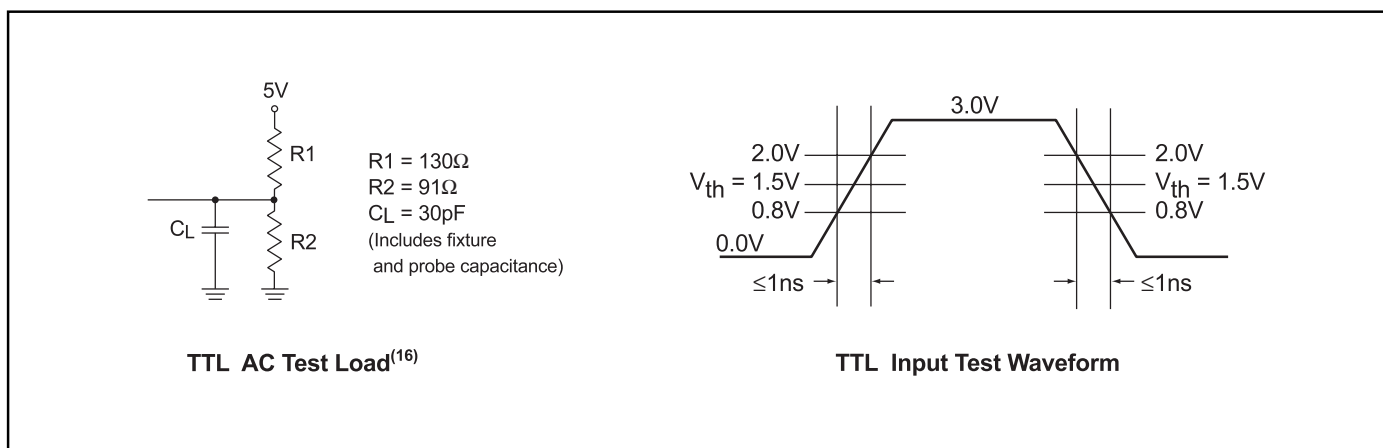



Switching Characteristics over the Operating Range^(2,11)

Parameter	Description		PI6C991-2			PI6C991-5			PI6C991		
			Min.	Typ.	Max.	Min.	Typ.	Max.	Min.	Typ.	Max.
F _{NOM}	Operating clock Frequency in MHz	FS = LOW ^(1,2)	15		30	15		30	15		30
		FS = MID ^(1,2)	25		50	25		50	25		50
		FS = HIGH ^(1,2,3)	40		80	40		80	40		80
t _{RPWH}	REF Pulse Width HIGH		5.0			5.0			5.0		
t _{RPWL}	REF Pulse Width LOW										
t _U	Programmable Skew Unit		See Table 1								
t _{SKWEWPR}	Zero Output Matched-Pair Skew (xQ0, xQ1) ^(13,14)			0.05	0.20		0.1	0.25		0.1	0.25
t _{SKEW0}	Zero Output Skew (All Outputs) ^(13,15)			0.10	0.25		0.25	0.5		0.3	0.75
t _{SKEW1}	Output Skew (Rise-Rise, Fall-Fall, Same Class Outputs) ^(13,17)			0.25	0.5		0.6	0.7		0.6	1.0
t _{SKEW2}	Output Skew (Rise-Fall, Nominal-Inverted, Divided-Divided) ^(13,17)			0.30	0.5		0.50	1.0		1.0	1.5
t _{SKEW3}	Output Skew (Rise-Rise, Fall-Fall, Different Class Outputs) ^(13,17)			0.25	0.5		0.50	0.7		0.7	1.2
t _{SKEW4}	Output Skew (Rise-Fall, Nominal-Divided, Divided-Inverted) ^(13,17)			0.50	0.9		0.50	1.0		1.2	1.7
t _{DEV}	Device-to-Device Skew ^(12,18)				0.75			1.25			1.65
t _{PD}	Propagation Delay, REF Rise to FB Rise		-0.25	0	0.25	-0.5	0	0.5	-0.7	0.0	+0.7
t _{ODCV}	Output Duty Cycle Variation ⁽¹⁹⁾		-0.65	0	0.65	-1.0	0	1.0	-1.2	0.0	+1.2
t _{PWH}	Output HIGH Time Deviation from 50% ⁽²⁰⁾				2.0			2.0			3.0
t _{PWL}	Output LOW Time Deviation from 50% ⁽²⁰⁾				1.5			2.5			3.5
t _{ORISE}	Output Rise Time ⁽²¹⁾		0.15	1.0	1.2	0.15	1.0	1.5	0.15	1.5	2.5
t _{OFALL}	Output Fall Time ⁽²¹⁾		0.15	1.0	1.2	0.15	1.0	1.5	0.15	1.5	2.5
t _{LOCK}	PLL Lock Time ⁽²²⁾				0.5			0.5			0.5
t _{JR}	Cycle-to Cycle Output Jitter	RMS ⁽¹²⁾			25			25			25
		Peak-to-Peak ⁽¹²⁾			200			200			200

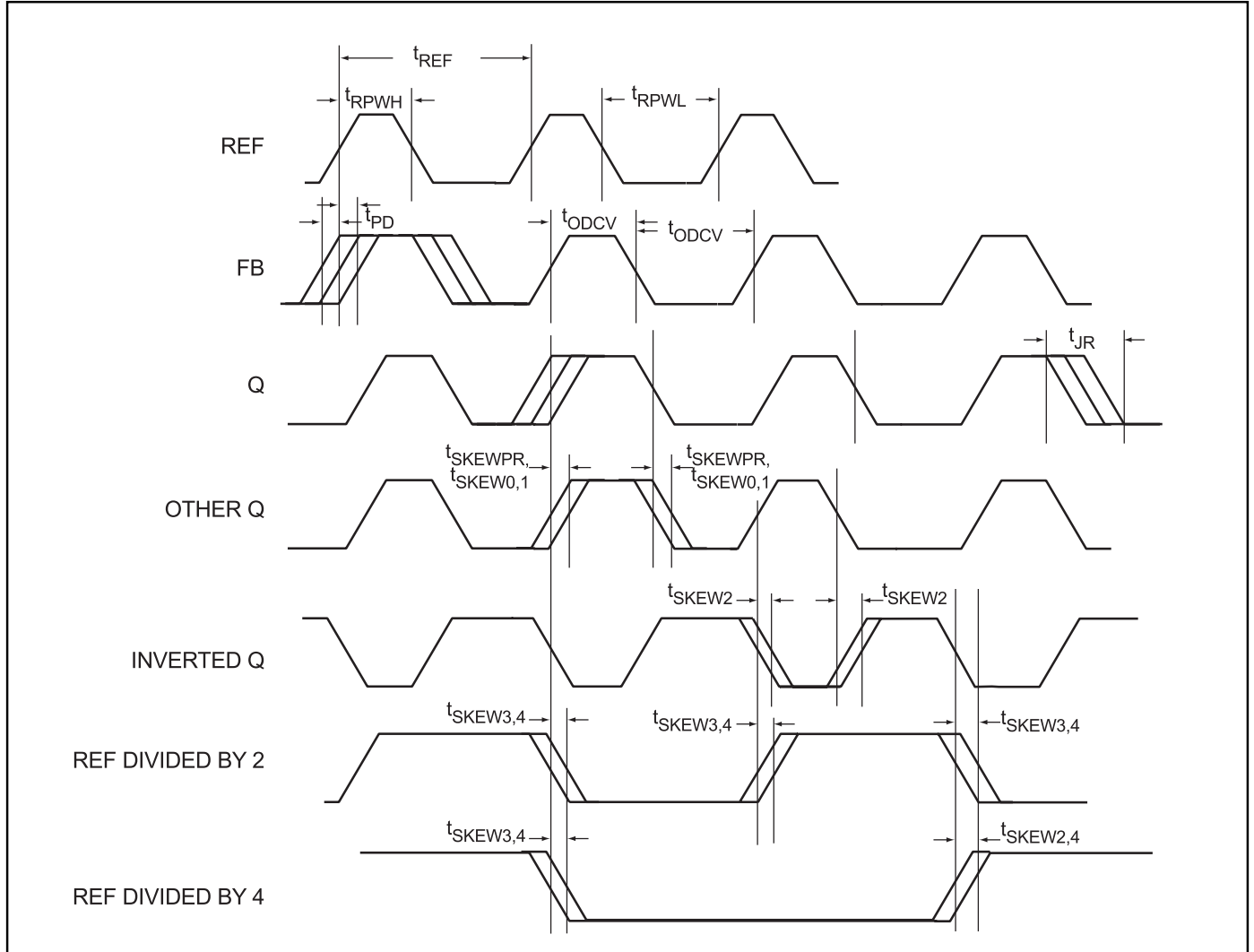
AC Timing Diagrams

Package Diagram 32-Pin PLCC (J32)

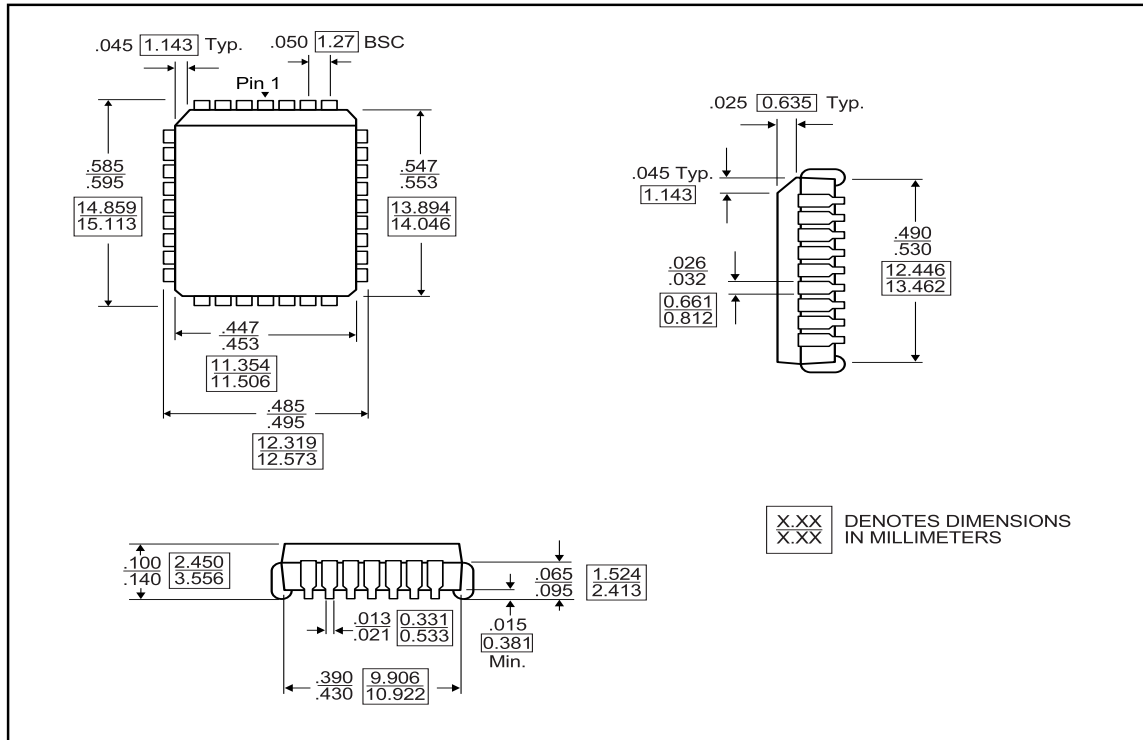

Ordering Information

Accuracy (ps)	Ordering Code	Package Name	Package Type	Operating Range
250	PI6C991-2J	J32	32-Lead Plastic Leaded Chip Carrier (PLCC)	Commercial
500	PI6C991-5J			
	PI6C991-5IJ			Industrial
750	PI6C991J			Commercial
	PI6C991-IJ			Industrial

Pericom Semiconductor Corporation

2380 Bering Drive • San Jose, CA 95131 • 1-800-435-2336 • Fax (408) 435-1100 • <http://www.pericom.com>