



## PI74FCT162Q245T

### Fast, Low Noise CMOS 16-Bit Bidirectional Transceivers

#### Product Features:

- $V_{CC} = 5V \pm 10\%$
- Balanced output drivers:  
     $\pm 12\text{ mA}$
- Output impedance:  
     $35\Omega$  (typical)
- Typical  $V_{OLP}$  (Output Ground Bounce)  $< 0.5V$   
    at  $V_{CC} = 5V$ ,  $T_A = 25^\circ C$
- Bus Hold retains last active bus state during tri-state
- Hysteresis on all inputs
- Packages available:
  - 48-pin 240-mil wide plastic TSSOP (A48)
  - 48-pin 300-mil wide plastic SSOP (V48)
  - 48-pin 150-mil wide plastic BQSOP (B48)
- Device models available on request

#### Product Description:

Pericom Semiconductor's PI74FCT series of logic circuits are produced in the Company's advanced 0.6 micron CMOS technology, achieving industry leading speed grades.

The PI74FCT162Q245T is a 16-bit bidirectional transceiver designed for asynchronous two-way communication between data buses. The direction control input pin (xDIR) determines the direction of data flow through the bidirectional transceiver. The Direction and Output Enable controls are designed to operate these devices as either two independent 8-bit transceivers or one 16-bit transceiver. The output enable ( $\overline{OE}$ ) input, when HIGH, disables both A and B ports by placing them in HIGH Z condition.

The PI74FCT162Q245T is designed with current limiting resistors at its outputs to control the output edge rate resulting in lower ground bounce and undershoot. This device features a typical output impedance of  $35\Omega$ , eliminating the need for external terminating resistors for most bus interface applications. This noise suppression benefit is designated by the letter "Q" (for quiet) in the part number.

The PI74FCT162Q245T also features "Bus Hold" which retains the input's last state whenever the input goes to high-impedance preventing "floating" inputs and eliminating the need for pullup/down resistors.

#### Logic Block Diagram

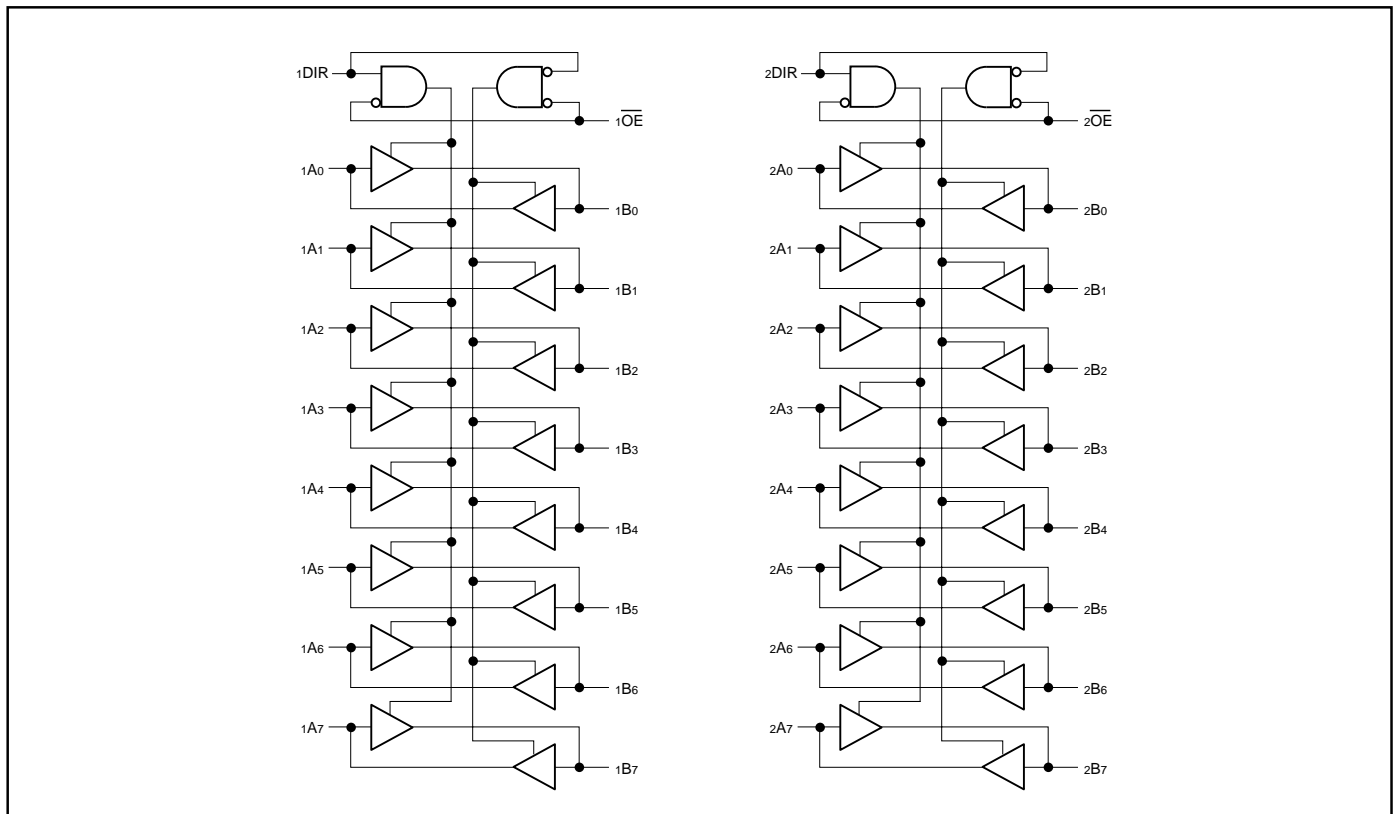

### Product Pin Description

Pin Name	Description
$\overline{xOE}$	Output Enable Inputs (Active LOW)
xDIR	Direction Control Input
xAx	Side A Inputs or 3-State Outputs <sup>(1)</sup>
xBx	Side B Inputs or 3-State Outputs <sup>(1)</sup>
GND	Ground
VCC	Power

**Note:** 1. For the PI74FCT162Q245T, these pins have "Bus Hold." All other pins are standard, outputs, or I/Os.

### Truth Table

Inputs <sup>(1)</sup>		Outputs <sup>(1)</sup>
$\overline{xOE}$	xDIR	
L	L	Bus B Data to Bus A
L	H	Bus A Data to Bus B
H	X	High Z State

**Note:** 1. H = High Voltage Level  
X = Don't Care  
L = Low Voltage Level  
Z = High Impedance

### Product Pin Configuration

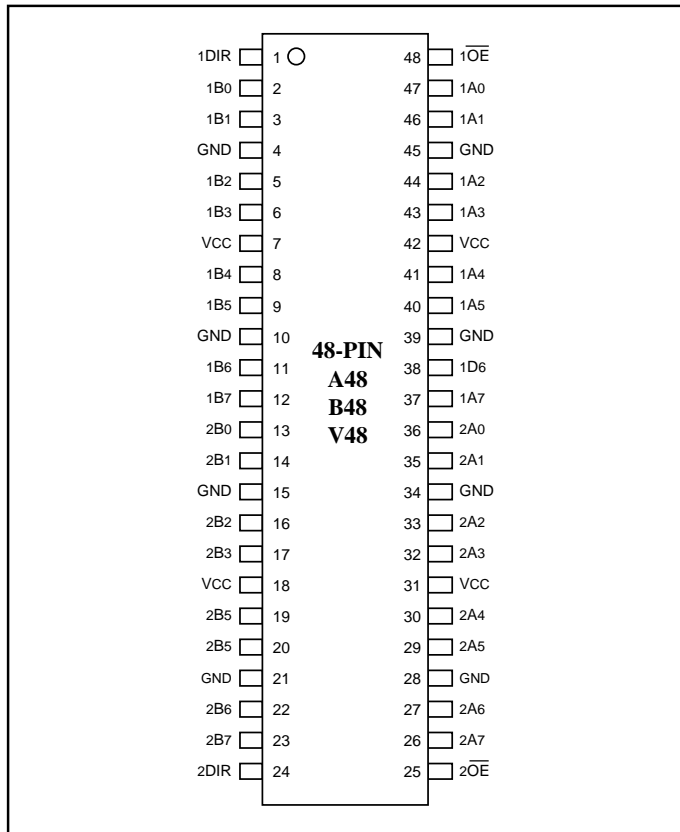

### Maximum Ratings

(Above which the useful life may be impaired. For user guidelines, not tested.)

Storage Temperature .....	-65°C to +150°C
Ambient Temperature with Power Applied .....	-40°C to +85°C
Supply Voltage to Ground Potential (Inputs & Vcc Only) .....	-0.5V to +7.0V
Supply Voltage to Ground Potential (Outputs & D/O Only) .....	-0.5V to +7.0V
DC Input Voltage .....	-0.5V to +7.0V
DC Output Current .....	120 mA
Power Dissipation .....	1.0W

**Note:**

Stresses greater than those listed under MAXIMUM RATINGS may cause permanent damage to the device. This is a stress rating only and functional operation of the device at these or any other conditions above those indicated in the operational sections of this specification is not implied. Exposure to absolute maximum rating conditions for extended periods may affect reliability.

### DC Electrical Characteristics (Over the Operating Range, TA = -40°C to +85°C, VCC = 5.0V ± 10%)

Parameters	Description	Test Conditions <sup>(1)</sup>		Min.	Typ <sup>(2)</sup>	Max.	Units
V <sub>IH</sub>	Input HIGH Voltage	Guaranteed Logic HIGH Level		2.0			V
V <sub>IL</sub>	Input LOW Voltage	Guaranteed Logic LOW Level				0.8	V
I <sub>IH</sub>	Input HIGH Current	Standard Input, V <sub>CC</sub> = Max.	V <sub>IN</sub> = V <sub>CC</sub>			1	μA
I <sub>IH</sub>	Input HIGH Current	Bus Hold Input <sup>(4)</sup> , V <sub>CC</sub> = Max.	V <sub>IN</sub> = V <sub>CC</sub>			±100	μA
I <sub>IL</sub>	Input LOW Current	Standard Input, V <sub>CC</sub> = Min.	V <sub>IN</sub> = GND			-1	μA
I <sub>IL</sub>	Input LOW Current	Bus Hold Input <sup>(4)</sup> , V <sub>CC</sub> = Min.	V <sub>IN</sub> = GND			±100	μA
I <sub>BHH</sub>	Bus Hold	Bus Hold Input <sup>(4)</sup> , V <sub>CC</sub> = Min.	V <sub>IN</sub> = 2.0V	-50			μA
I <sub>BHL</sub>	Sustain Current		V <sub>IN</sub> = 0.8V	+50			
I <sub>OZH</sub>	High Impedance	V <sub>CC</sub> = Max.	V <sub>OUT</sub> = V <sub>CC</sub>			1	μA
I <sub>OZL</sub>	Output Current	V <sub>CC</sub> = Max.	V <sub>OUT</sub> = GND			-1	μA
V <sub>IK</sub>	Clamp Diode Voltage	V <sub>CC</sub> = Min., I <sub>IN</sub> = -18 mA			-0.7	-1.2	V
I <sub>O</sub>	Output Drive Current	V <sub>CC</sub> = Max. <sup>(3)</sup> , V <sub>OUT</sub> = 2.5V		-50		-180	mA
V <sub>H</sub>	Input Hysteresis				100		mV

**Notes:**

1. For Max. or Min. conditions, use appropriate value specified under Electrical Characteristics for the applicable device type.
2. Typical values are at V<sub>CC</sub> = 5.0V, +25°C ambient and maximum loading.
3. Not more than one output should be shorted at one time. Duration of the test should not exceed one second.
4. Pins with Bus Hold are identified in the pin description.
5. This specification does not apply to bi-directional functionalities with Bus Hold.

**Output Drive Characteristics** (Over the Operating Range)

Parameters	Description	Test Conditions <sup>(1)</sup>	Min.	Typ <sup>(2)</sup>	Max.	Units
I <sub>ODL</sub>	Output LOW Current	V <sub>CC</sub> = 5V, V <sub>IN</sub> = V <sub>IH</sub> OR V <sub>IL</sub> , V <sub>OUT</sub> = 1.5V <sup>(3)</sup>	36	—	—	mA
I <sub>ODH</sub>	Output HIGH Current	V <sub>CC</sub> = 5V, V <sub>IN</sub> = V <sub>IH</sub> OR V <sub>IL</sub> , V <sub>OUT</sub> = 1.5V <sup>(3)</sup>	-100	-166	-200	mA

**Output Drive Characteristics** (Over the Operating Range)

Parameters	Description	Test Conditions <sup>(1)</sup>	Min.	Typ <sup>(2)</sup>	Max.	Units
V <sub>OH</sub>	Output HIGH Voltage	V <sub>CC</sub> = Min., V <sub>IN</sub> = V <sub>IH</sub> OR V <sub>IL</sub>   I <sub>OH</sub> = -12.0 mA	2.4	3.3	—	V
V <sub>OL</sub>	Output LOW Voltage	V <sub>CC</sub> = Min., V <sub>IN</sub> = V <sub>IH</sub> OR V <sub>IL</sub>   I <sub>OL</sub> = 12 mA	—	0.4	0.55	V

**Capacitance** (T<sub>A</sub> = 25°C, f = 1 MHz)

Parameters <sup>(4)</sup>	Description	Test Conditions	Typ	Max.	Units
C <sub>IN</sub>	Input Capacitance	V <sub>IN</sub> = 0V	4.5	6	pF
C <sub>OUT</sub>	Output Capacitance	V <sub>OUT</sub> = 0V	5.5	8	pF

**Notes:**

1. For Max. or Min. conditions, use appropriate value specified under Electrical Characteristics for the applicable device type.
2. Typical values are at V<sub>CC</sub> = 5.0V, +25°C ambient and maximum loading.
3. Not more than one output should be tested at one time. Duration of the test should not exceed one second.
4. This parameter is determined by device characterization but is not production tested.

### Power Supply Characteristics

Parameters	Description	Test Conditions <sup>(1)</sup>		Min.	Typ <sup>(2)</sup>	Max.	Units
I <sub>CC</sub>	Quiescent Power Supply Current	V <sub>CC</sub> = Max.	V <sub>IN</sub> = GND or V <sub>CC</sub>		0.1	500	μA
ΔI <sub>CC</sub>	Supply Current per Input @ TTL HIGH	V <sub>CC</sub> = Max.	V <sub>IN</sub> = 3.4V <sup>(3)</sup>		0.5	1.5	mA
I <sub>CCD</sub>	Supply Current per Input per MHz <sup>(4)</sup>	V <sub>CC</sub> = Max., Outputs Open x $\overline{OE}$ = xDIR = GND One Bit Toggling 50% Duty Cycle	V <sub>IN</sub> = V <sub>CC</sub> V <sub>IN</sub> = GND		60	100	μA/ MHz
I <sub>C</sub>	Total Power Supply Current <sup>(6)</sup>	V <sub>CC</sub> = Max., Outputs Open f <sub>i</sub> = 10 MHz 50% Duty Cycle x $\overline{OE}$ = xDIR = GND One Bit Toggling	V <sub>IN</sub> = V <sub>CC</sub> V <sub>IN</sub> = GND		0.6	1.5 <sup>(5)</sup>	mA
			V <sub>IN</sub> = 3.4V V <sub>IN</sub> = GND		0.9	2.3 <sup>(5)</sup>	
		V <sub>CC</sub> = Max., Outputs Open f <sub>i</sub> = 2.5 MHz 50% Duty Cycle x $\overline{OE}$ = xDIR = GND 16 Bits Toggling	V <sub>IN</sub> = V <sub>CC</sub> V <sub>IN</sub> = GND		2.4	4.5 <sup>(5)</sup>	
			V <sub>IN</sub> = 3.4V V <sub>IN</sub> = GND		6.4	16.5 <sup>(5)</sup>	

#### Notes:

- For conditions shown as Max. or Min., use appropriate value specified under Electrical Characteristics for the applicable device.
- Typical values are at V<sub>CC</sub> = 5.0V, +25°C ambient.
- Per TTL driven input (V<sub>IN</sub> = 3.4V); all other inputs at V<sub>CC</sub> or GND.
- This parameter is not directly testable, but is derived for use in Total Power Supply Calculations.
- Values for these conditions are examples of the I<sub>CC</sub> formula. These limits are guaranteed but not tested.

$$I_C = I_{\text{QUIESCENT}} + I_{\text{INPUTS}} + I_{\text{DYNAMIC}}$$

$$I_C = I_{CC} + \Delta I_{CC} D_H N_T + I_{CCD} (f_{CP}/2 + f_i N_i)$$

I<sub>CC</sub> = Quiescent Current

ΔI<sub>CC</sub> = Power Supply Current for a TTL High Input (V<sub>IN</sub> = 3.4V)

D<sub>H</sub> = Duty Cycle for TTL Inputs High

N<sub>T</sub> = Number of TTL Inputs at D<sub>H</sub>

I<sub>CCD</sub> = Dynamic Current Caused by an Input Transition Pair (HLH or LHL)

f<sub>CP</sub> = Clock Frequency for Register Devices (Zero for Non-Register Devices)

f<sub>i</sub> = Input Frequency

N<sub>i</sub> = Number of Inputs at f<sub>i</sub>

All currents are in milliamps and all frequencies are in megahertz.



**Switching Characteristics over Operating Range**

Parameters	Description	Conditions <sup>(1)</sup>	162Q245T		162Q245AT		162Q245CT		162Q245DT		162Q245ET		Unit
			Com.		Com.		Com.		Com.		Com.		
			Min	Max	Min	Max	Min	Max	Min	Max	Min	Max	
tPLH tPHL	Propagation Delay A to B, B to A	CL = 50 pF RL = 500Ω	1.5	7.0	1.5	4.6	1.5	4.1	1.5	3.8	1.5	3.2	ns
tpZH tpZL	Output Enable Time xOE to A or B		1.5	9.5	1.5	6.2	1.5	5.8	1.5	5.0	1.5	4.4	ns
tpHZ tplZ	Output Disable Time <sup>(3)</sup> xOE to A or B		1.5	7.5	1.5	5.0	1.5	4.8	1.5	4.3	1.5	4.0	ns
tpZH tpZL	Output Enable Time xDIR to A or B <sup>(3)</sup>		1.5	9.5	1.5	6.2	1.5	5.8	1.5	5.0	1.5	4.8	ns
tpHZ tplZ	Output Disable Time xDIR to A or B <sup>(3)</sup>		1.5	7.5	1.5	5.0	1.5	4.8	1.5	4.3	1.5	4.0	ns
tsk(o)	Output Skew <sup>(4)</sup>		—	0.5	—	0.5	—	0.5	—	0.5	—	0.5	ns

**Notes:**

1. See test circuit and waveforms.
2. Minimum limits are guaranteed but not tested on Propagation Delays.
3. This parameter is guaranteed but not production tested.
4. Skew between any two outputs, of the same package, switching in the same direction. This parameter is guaranteed by design.