



PI74FCT163374

Fast CMOS 3.3V 16-Bit Register (3-State)

Product Features

- Advanced Low Power CMOS Operation
- Can serve as a 5V to 3V translator
- Excellent output drive capability:
Balanced drives (24 mA sink and source)
Compatible with LVC™ class of products.
- Pin compatible with industry standard double-density pinouts
- Low ground bounce outputs
- Hysteresis on all inputs
- Industrial operating temperature range: -40°C to $+85^{\circ}\text{C}$
- Inputs can be driven by 3.3V or 5V devices
- Multiple center pin and distributed Vcc/GND pins minimizing switching noise
- Packages available:
 - 48-pin 240 mil wide plastic TSSOP (A)
 - 48-pin 300 mil wide plastic SSOP (V)
 - 48-pin 173 mil wide plastic TVSOP (K)

Product Description

Pericom Semiconductor's PI74FCT series of logic circuits are produced in the Company's advanced 0.6 micron CMOS technology, achieving industry leading speed grades.

The PI74FCT163374 is a 16-bit octal register designed with 16 D-type flip-flops with a buffered common clock and 3-state outputs. The Output Enable (\overline{xOE}) and clock ($xCLK$) controls are organized to operate as two 8-bit registers or one 16-bit register. When \overline{OE} is HIGH, the outputs are in the high-impedance state. Input data meeting the setup and hold time requirements of the D inputs is transferred to the O outputs on the LOW-to-HIGH transition of the clock input.

Logic Block Diagram

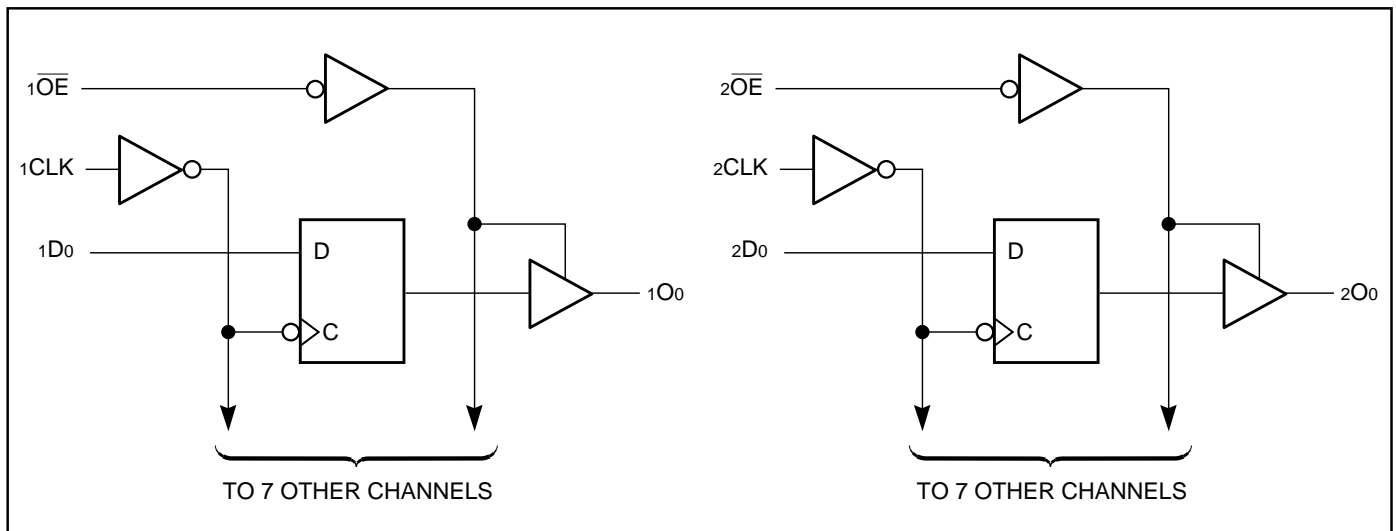

Product Pin Description

Pin Name	Description
\overline{xOE}	3-State Output Enable Inputs (Active LOW)
xCLK	Clock Inputs
xDx	Data Inputs
xOx	3-State Outputs
GND	Ground
Vcc	Power

Truth Table

Function	Inputs ⁽¹⁾			Outputs ⁽¹⁾
	xDx	xCLK	\overline{xOE}	xOx
High-Z	X	L	H	Z
	X	H	H	Z
Load Register	L		L	L
	H		L	H
	L		H	Z
	H		H	Z

Product Pin Configuration

$\overline{1OE}$	1		48	1CLK
1O0	2		47	1D0
1O1	3		46	1D1
GND	4		45	GND
1O2	5		44	1D2
1O3	6		43	1D3
Vcc	7		42	Vcc
1O4	8		41	1D4
1O5	9	48-PIN V48 A48 K48	40	1D5
GND	10		39	GND
1O6	11		38	1D6
1O7	12		37	1D7
2O0	13		36	2D0
2O1	14		35	2D1
GND	15		34	GND
2O2	16		33	2D2
2O3	17		32	2D3
Vcc	18		31	Vcc
2O4	19		30	2D4
2O5	20		29	2D5
GND	21		28	GND
2O6	22		27	2D6
2O7	23		26	2D7
$\overline{2OE}$	24		25	2CLK

Note:

- H = High Voltage Level, X = Don't Care,
L = Low Voltage Level, Z = High Impedance

Capacitance (T_A = 25°C, f = 1 MHz)

Parameters ⁽¹⁾	Description	Test Conditions	Typ	Max.	Units
C _{IN}	Input Capacitance	V _{IN} = 0 V	4.5	6	pF
C _{OUT}	Output Capacitance	V _{OUT} = 0 V	5.5	8	pF

Note:

- This parameter is determined by device characterization but is not production tested.

Maximum Ratings

(Above which the useful life may be impaired. For user guidelines, not tested.)

Storage Temperature	-55°C to +125°C
Ambient Temperature with Power Applied	-40°C to +85°C
Supply Voltage to Ground Potential (Inputs & Vcc Only) ...	-0.5V to +7.0V
Supply Voltage to Ground Potential (Outputs & D/O Only)	-0.5V to +7.0V
DC Input Voltage	-0.5V to +7.0V
DC Output Current	120 mA
Power Dissipation	1.0W

Note:

Stresses greater than those listed under MAXIMUM RATINGS may cause permanent damage to the device. This is a stress rating only and functional operation of the device at these or any other conditions above those indicated in the operational sections of this specification is not implied. Exposure to absolute maximum rating conditions for extended periods may affect reliability.

DC Electrical Characteristics (Over the Operating Range, $T_A = -40^\circ\text{C}$ to $+85^\circ\text{C}$, $V_{CC} = 2.7\text{V}$ to 3.6V)

Parameters	Description	Test Conditions ⁽¹⁾		Min.	Typ. ⁽²⁾	Max.	Units
V _{IH}	Input HIGH Voltage (Input pins)	Guaranteed Logic HIGH Level		2.2	—	5.5	V
	Input HIGH Voltage (I/O pins)			2.0	—	V _{CC} +0.5	V
V _{IL}	Input LOW Voltage (Input and I/O pins)	Guaranteed Logic LOW Level		-0.5	—	0.8	V
I _{IH}	Input HIGH Current (Input pins)	V _{CC} = Max.	V _{IN} = 5.5V	—	—	±1	μA
	Input HIGH Current (I/O pins)	V _{CC} = Max.	V _{IN} = V _{CC}	—	—	±1	μA
I _{IL}	Input LOW Current (Input pins)	V _{CC} = Max.	V _{IN} = GND	—	—	±1	μA
	Input LOW Current (I/O pins)	V _{CC} = Max.	V _{IN} = GND	—	—	±1	μA
I _{OZH}	High Impedance Output Current (3-State Output pins)	V _{CC} = Max.	V _{OUT} = V _{CC}	—	—	±1	μA
I _{OZL}		V _{CC} = Max.	V _{OUT} = GND	—	—	±1	μA
V _{IK}	Clamp Diode Voltage	V _{CC} = Min., I _{IN} = -18mA		—	-0.7	-1.2	V
I _{ODH}	Output HIGH Current	V _{CC} = 3.3V, V _{IN} = V _{IH} or V _{IL} , V _O = 1.5V ⁽³⁾		-36	-60	-110	mA
I _{ODL}	Output LOW Current	V _{CC} = 3.3V, V _{IN} = V _{IH} or V _{IL} , V _O = 1.5V ⁽³⁾		50	90	200	mA
V _{OH}	Output HIGH Voltage	V _{CC} = Min.	I _{OH} = -0.1mA	V _{CC} -0.2	—	—	V
		V _{IN} = V _{IH} or V _{IL}	I _{OH} = -3mA	2.4	3.0	—	V
		V _{CC} = 3.0V,	I _{OH} = -8mA	2.4 ⁽⁵⁾	3.0	—	V
		V _{IN} = V _{IH} or V _{IL}	I _{OH} = -24mA	2.0	—	—	V
V _{OL}	Output LOW Voltage	V _{CC} = Min.	I _{OL} = 0.1mA	—	—	0.2	V
		V _{IN} = V _{IH} or V _{IL}	I _{OL} = 16mA	—	0.2	0.4	V
		V _{IN} = V _{IH} or V _{IL}	I _{OL} = 24mA	—	0.3	0.5	V
I _{OS} mA	Short Circuit Current ⁽⁴⁾	V _{CC} = Max. ⁽³⁾ , V _{OUT} = GND		—	-60	-85	-240

V _{IH}	Input Hysteresis	—	150	—	mV
-----------------	------------------	---	-----	---	----

Notes:

- For Max. or Min. conditions, use appropriate value specified under Electrical Characteristics for the applicable device type.
- Typical values are at V_{CC} = 3.3V, +25°C ambient and maximum loading.
- Not more than one output should be shorted at one time. Duration of the test should not exceed one second.
- This parameter is guaranteed but not tested.
- V_{OH} = V_{CC} - 0.6V at rated current.

Power Supply Characteristics

Parameters	Description	Test Conditions ⁽¹⁾		Min.	Typ. ⁽²⁾	Max.	Units
ICC	Quiescent Power Supply Current	VCC = Max.	VIN = GND or VCC		0.1	10	μA
ΔICC	Quiescent Power Supply Current TTL Inputs HIGH	VCC = Max.	VIN = VCC – 0.6V ⁽³⁾		2.0	30	μA
ICCD	Dynamic Power Supply ⁽⁴⁾	VCC = Max., Outputs Open XOE = GND One Bit Toggling 50% Duty Cycle	VIN = VCC VIN = GND		50	75	μA/ MHz
IC	Total Power Supply Current ⁽⁶⁾	VCC = Max., Outputs Open fi = 10 MHz 50% Duty Cycle XOE = GND One Bit Toggling	VIN = VCC – 0.6V VIN = GND		0.5	0.8	mA
		VCC = Max., Outputs Open fi = 2.5 MHz 50% Duty Cycle XOE = GND 16 Bits Toggling	VIN = VCC – 0.6V VIN = GND		2.5	4.0 ⁽⁵⁾	

Notes:

1. For Max. or Min. conditions, use appropriate value specified under Electrical Characteristics for the applicable device.
2. Typical values are at Vcc = 3.3V, +25°C ambient.
3. Per TTL driven input; all other inputs at Vcc or GND.
4. This parameter is not directly testable, but is derived for use in Total Power Supply Calculations.
5. Values for these conditions are examples of the Icc formula. These limits are guaranteed but not tested.
6. IC = IQUIESCENT + IINPUTS + IDYNAMIC
 IC = ICC + ΔICC DHNT + ICCD (fCP/2 + fiNI)
 ICC = Quiescent Current (ICCL, ICCH and ICCZ)
 ΔICC = Power Supply Current for a TTL High Input
 DH = Duty Cycle for TTL Inputs High
 NT = Number of TTL Inputs at DH
 ICCD = Dynamic Current Caused by an Input Transition Pair (HLH or LHL)
 fCP = Clock Frequency for Register Devices (Zero for Non-Register Devices)
 NCP = Number of Clock Inputs at fCP
 fi = Input Frequency
 NI = Number of Inputs at fi
 All currents are in milliamps and all frequencies are in megahertz.

Switching Characteristics over Operating Range⁽¹⁾

Parameters	Description	Conditions ⁽²⁾	FCT163374		FCT163374A		FCT163374C		Units
			Com.		Com.		Com.		
			Min. ⁽³⁾	Max.	Min. ⁽³⁾	Max.	Min. ⁽³⁾	Max.	
tPLH tPHL	Propagation Delay xCLK to xOx	CL = 50pF RL = 500Ω	2.0	10.0	2.0	6.5	2.0	5.2	ns
tPZH tPZL	Output Enable Time xOE to xOx		1.5	12.5	1.5	6.5	1.5	5.5	ns
tPHZ tPLZ	Output Disable Time ⁽⁴⁾ xOE to xOx		1.5	8.0	1.5	5.5	1.5	5.0	ns
tSU	Setup Time HIGH or LOW, xDx to xCLK		2.0		2.0		2.0		ns
tH	Hold Time HIGH or LOW, xDx to xCLK		1.5		1.5		1.5		ns
tW	xCLK Pulse Width HIGH ⁽⁴⁾		7.0		5.0		5.0		ns
tSK(o)	Output Skew ⁽⁵⁾			0.5		0.5		0.5	ns

Notes:

1. Propagation Delays and Enable/Disable times are with $V_{cc} = 3.3V \pm 0.3V$, normal range. For $V_{cc} = 2.7V$, extended range, all Propagation Delays and Enable/Disable times should be degraded by 20%.
2. See test circuit and wave forms.
3. Minimum limits are guaranteed but not tested on Propagation Delays.
4. This parameter is guaranteed but not production tested.
5. Skew between any two outputs, of the same package, switching in the same direction. This parameter is guaranteed by design.