



**PI74FCT16511T
PI74FCT162511T**

Product Features:

Common Features:

- PI74FCT16511 and PI74FCT162511 are high-speed, low power devices with high current drive.
- $V_{CC} = 5V \pm 10\%$
- Typical $t_{sk(o)}$ (Output Skew) < 250 ps, clocked mode
- Extended range of $-40^{\circ}C$ to $+85^{\circ}C$
- Hysteresis on all inputs
- Packages available:
 - 56-pin 240 mil wide TSSOP (A)
 - 56-pin 300 mil wide SSOP (V)

PI74FCT16511T Features:

- High output drive: $I_{OH} = -32$ mA; $I_{OL} = 64$ mA
- Power off disable outputs permit “live insertion”
- Typical V_{OLP} (Output Ground Bounce) < 1.0V at $V_{CC} = 5V$, $T_A = 25^{\circ}C$

PI74FCT162511T Features:

- High output drive: $I_{OL}/I_{OH} = 24$ mA
- Open drain parity error allows wire-OR
- Typical V_{OLP} (Output Ground Bounce) < 1.0V at $V_{CC} = 5V$, $T_A = 25^{\circ}C$
- Balanced output drivers: ± 24 mA
- Series current limiting resistors

Fast CMOS 16-Bit Registered/Latched Transceiver With Parity

Product Description:

Pericom Semiconductor’s PI74FCT series of logic circuits are produced in the Company’s advanced 0.8 micron CMOS technology, achieving industry leading speed grades.

The PI74FCT16511T and PI74FCT162511T are high-speed, low-power 16-bit registered/latched transceiver with parity which combines D-type latches and D-type flip-flops to allow data flow in transparent, latched or clocked modes. It has a parity generator/checker in the A-to-B direction and a parity checker in the B-to-A direction. Error checking is done at the byte level with separate parity bits for each byte. One error flag for each direction (A-to-B or B-to-A) exists to indicate an error for either byte in either direction. The parity error flags which are open drain outputs, can be tied together and/or tied with flags from other devices to form a single error flag or interrupt. To disable the error flag during combinational transitions, a designer can disable the parity error flag by the $\overline{OE_{xx}}$ control pins.

The operation in A-to-B direction is controlled by LEAB, CLKAB and \overline{OEAB} control pins, and the operation in B-to-A direction is controlled by LEBA, CLKBA and \overline{OEBA} control pins. $\overline{GEN}/\overline{CHK}$ is used to select the operation of A-to-B direction, while B-to-A direction is always in checking mode. The $\overline{ODD}/\overline{EVEN}$ select is common between the two directions. Independent operation can be achieved between the two directions by using the corresponding control lines except for the $\overline{ODD}/\overline{EVEN}$ control.

Simplified Logic Block Diagram

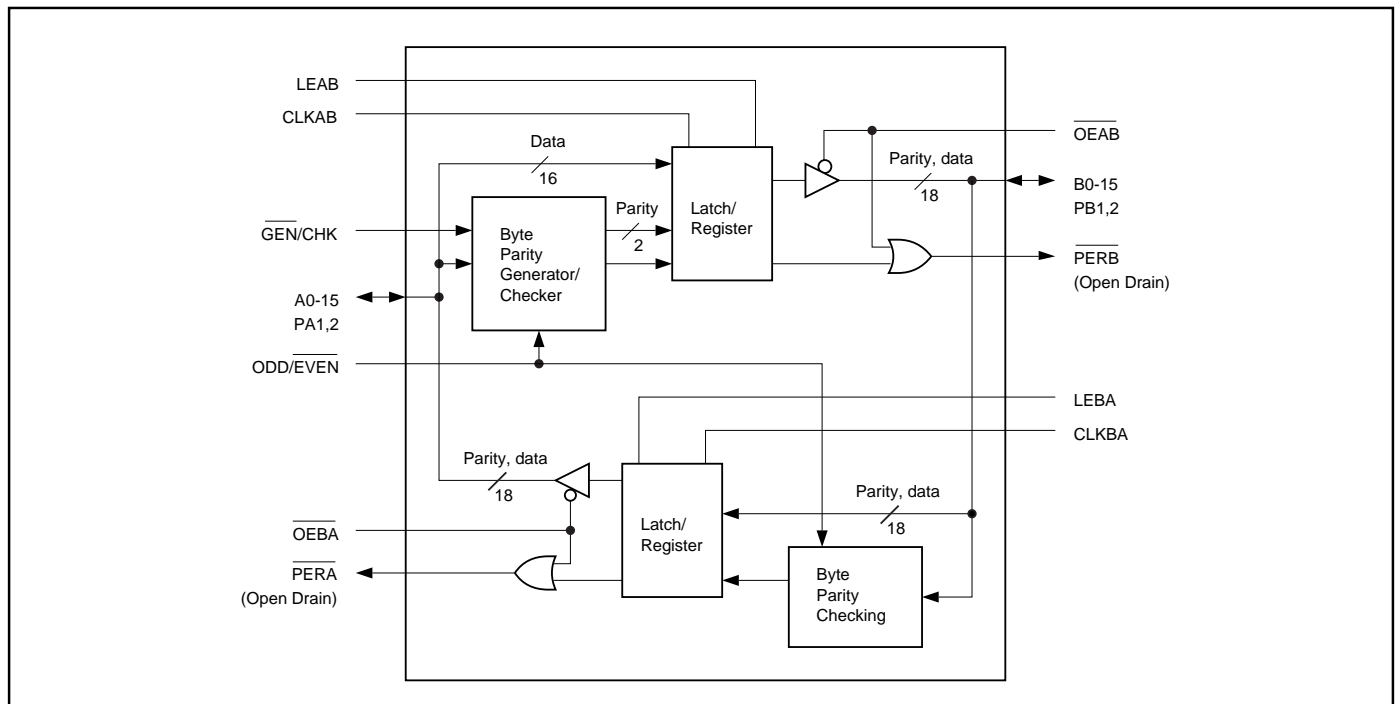

Logic Block Diagram

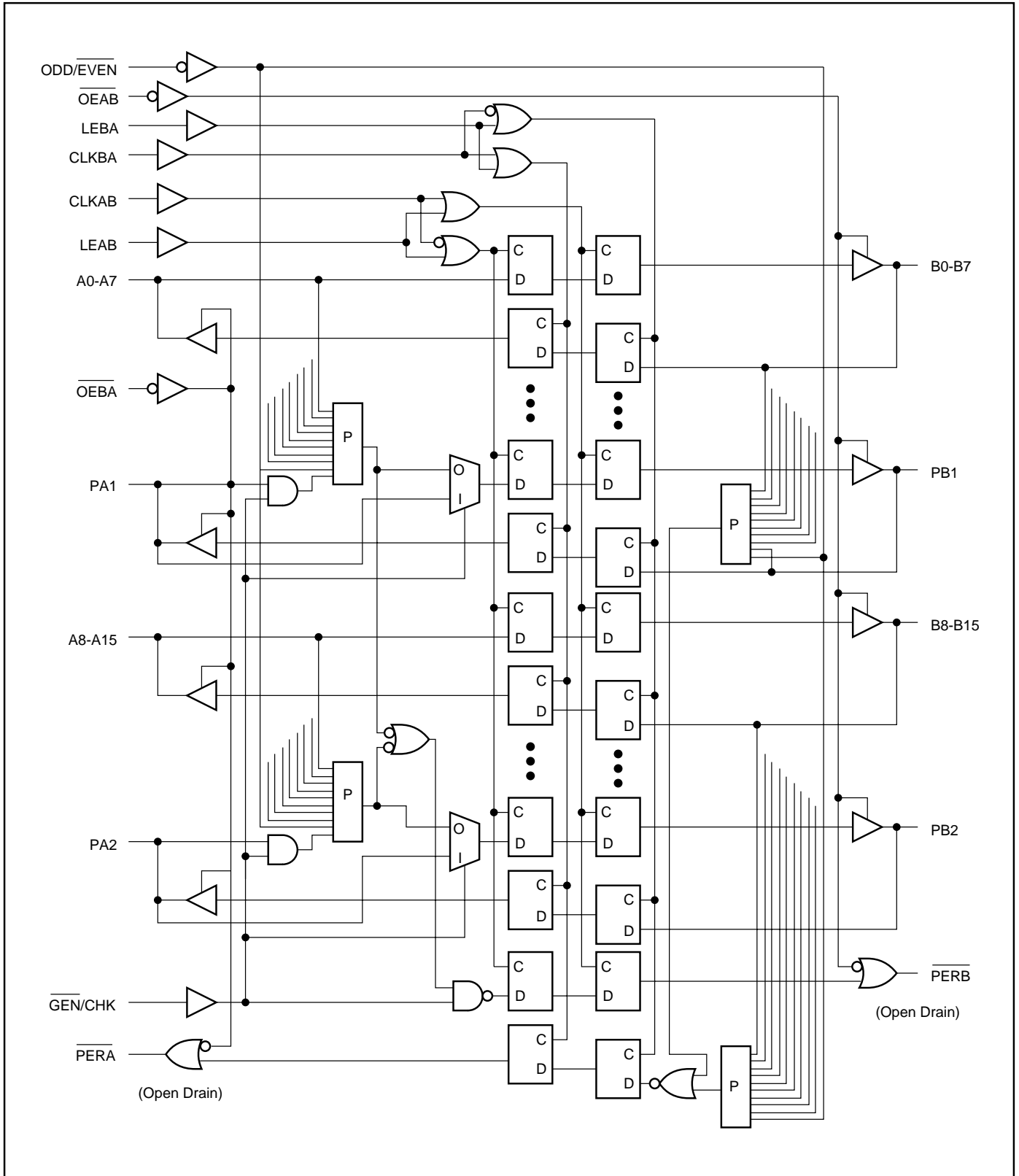



Product Pin Description

| Pin Name | Description |
|-----------------------------|--|
| \overline{OEAB} | A-to-B Output Enable Input (Active LOW) |
| \overline{OEBA} | B-to-A Output Enable Input (Active LOW) |
| CLKAB | A-to-B Clock Input |
| CLKBA | B-to-A Clock Input |
| LEAB | A-to-B Latch Enable Input |
| LEBA | B-to-A Latch Enable Input |
| \overline{PERA} | Parity Error (Open Drain) on A Outputs |
| \overline{PERB} | Parity Error (Open Drain) on B Outputs |
| Ax | A-to-B Data Inputs or B-to-A 3-State Outputs |
| Bx | B-to-A Data Inputs or B-to-A 3-State Outputs |
| $\overline{ODD/EVEN}^{(1)}$ | Parity Mode Selection Input |
| $\overline{GEN/CHK}^{(1)}$ | A-to-B Port Generate or Check Mode Input |
| $\overline{PAX}^{(2)}$ | A-to-B Parity Input, B-to-A Parity Output |
| PBx | B-to-A Parity Input, A-to-B Parity Output |
| GND | Ground |
| Vcc | Power |

NOTES:

1. $\overline{ODD/EVEN}$ and $\overline{GEN/CHK}$ should be tied to Vcc or GND with no resistor for optimum results.
2. The PAX pin input is internally disabled during parity generation. This means that when generating parity in the A-to-B direction, there is no need to add a pull-up resistor to guarantee state. The pin will still function properly as the parity output for the B-to-A direction.

Product Pin Configuration

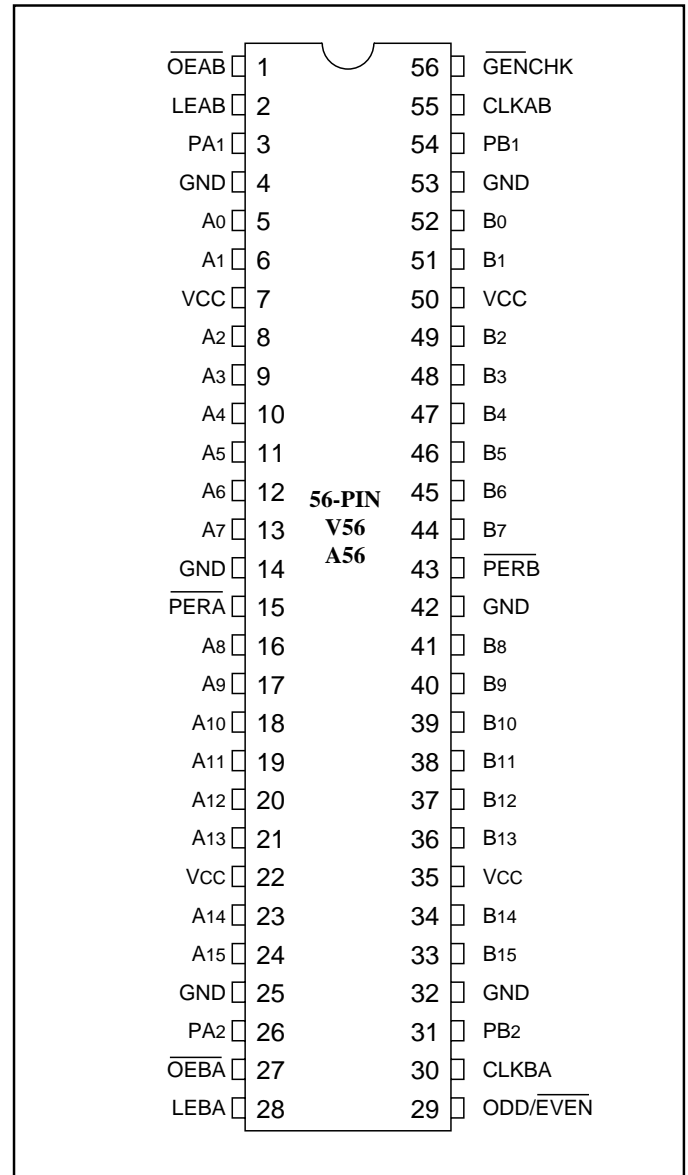

Capacitance ($T_A = 25^\circ\text{C}$, $f = 1\text{ MHz}$)

| Parameters ⁽¹⁾ | Description | Test Conditions | Typ | Max. | Units |
|---------------------------|------------------------|-----------------|-----|------|-------|
| C_{IN} | Input Capacitance | $V_{IN} = 0V$ | 4.5 | 6.0 | pF |
| $C_{I/O}$ | I/O Capacitance | $V_{OUT} = 0V$ | 5.5 | 8.0 | pF |
| C_o | Open Drain Capacitance | $V_{OUT} = 0V$ | 4.5 | 6.0 | pF |

Note:

1. This parameter is determined by device characterization but is not production tested.

Truth Table^(1,2)

| Inputs | | | | Output Buffers |
|--------|------|-------|----------------|------------------|
| OEAB | LEAB | CLKAB | A _x | B _x |
| H | X | X | X | Z |
| L | H | X | L | L |
| L | H | X | H | H |
| L | L | ↑ | L | L |
| L | L | ↑ | H | H |
| L | L | L | X | B ⁽³⁾ |
| L | L | H | X | B ⁽⁴⁾ |

NOTES:

- H = High Voltage Level
L = Low Voltage Level
X = Don't Care or Irrelevant
Z = High Impedance
↑ = LOW-to-HIGH Transition
- A-to-B data flow is shown. B-to-A flow control is the same, except using OEBA, LEBA, and CLKBA.
- Output level before the indicated steady-state input conditions were established.
- Output level before the indicated steady-state input conditions were established, assuming CLKAB was HIGH before LEAB went LOW.

Truth Table (Parity Generation) (1, 2, 3, 4, 5)

| A0 - A7, Total Number of Inputs that are high | ODD/EVEN | PB1 |
|---|----------|-----|
| 1, 3, 5 or 7 | L | H |
| 1, 3, 5 or 7 | H | L |
| 0, 2, 4, 6 or 8 | L | L |
| 0, 2, 4, 6 or 8 | H | H |

NOTES:

- Conditions shown are for $\overline{\text{GEN/CHK}} = \text{L}$, $\overline{\text{OEAB}} = \text{L}$, $\overline{\text{OEBA}} = \text{H}$.
- A-to-B parity generation is shown. B-to-A can check parity while A-to-B is performing generation. B-to-A will not generate parity.
- The response shown is for LEAB = H. If LEAB = L, then CLKAB will control as an edge triggered clock.
- Conditions shown are for the byte A0-A7. The byte A8-A15 is similar but will output the parity on PB2.
- The error flag PERB will remain in a high state during parity generation.

Truth Table (Parity Checking) (1, 2, 3, 4)

| A0 - A7 and PA1 ⁽⁵⁾ , Total Number of Inputs that are high | ODD/EVEN | PERB |
|---|----------|------------------|
| 1, 3, 5, 7 or 9 | L | L |
| 1, 3, 5, 7 or 9 | H | H ⁽⁶⁾ |
| 0, 2, 4, 6 or 8 | L | H ⁽⁶⁾ |
| 0, 2, 4, 6 or 8 | H | L |

NOTES:

- Conditions shown are for $\overline{\text{GEN/CHK}} = \text{H}$, $\overline{\text{OEAB}} = \text{L}$, $\overline{\text{OEBA}} = \text{H}$.
- A-to-B parity checking is shown. B-to-A parity checking is same but uses OEBA = L, OEAB = H and errors will be indicated on PERA.
- In parity checking mode the parity bits will be transmitted unchanged along with the corresponding data regardless of parity errors. (PB1 = PA1)
- The response shown is for LEAB = H. If LEAB = L, then CLKAB will control as an edge triggered clock.
- Conditions shown are for the byte A0-A7 and PA1. The byte A8-A15 and PA2 is same.
- The parity error flag PERB is a combined flag for both bytes A0-A7 and A8-A15. If a parity error occurs on either byte PERB will go low.



Maximum Ratings

(Above which the useful life may be impaired. For user guidelines, not tested.)

| | |
|---|-----------------|
| Storage Temperature | -65°C to +150°C |
| Ambient Temperature with Power Applied | -40°C to +85°C |
| Supply Voltage to Ground Potential (Inputs & Vcc Only) | -0.5V to +7.0V |
| Supply Voltage to Ground Potential (Outputs & D/O Only) | -0.5V to +7.0V |
| DC Input Voltage | -0.5V to +7.0V |
| DC Output Current | 120mA |
| Power Dissipation | 1.0W |

Note:

Stresses greater than those listed under MAXIMUM RATINGS may cause permanent damage to the device. This is a stress rating only and functional operation of the device at these or any other conditions above those indicated in the operational sections of this specification is not implied. Exposure to absolute maximum rating conditions for extended periods may affect reliability.

DC Electrical Characteristics (Over the Operating Range, TA = -40°C to +85°C, VCC = 5.0V ± 10%)

| Parameters | Description | Test Conditions ⁽¹⁾ | Min. | Typ ⁽²⁾ | Max. | Units |
|------------------|-------------------------------------|---|-------------------------|--------------------|------|-------|
| V _{IH} | Input HIGH Voltage | Guaranteed Logic HIGH Level | 2.0 | | | V |
| V _{IL} | Input LOW Voltage | Guaranteed Logic LOW Level | | | 0.8 | V |
| I _{IH} | Input HIGH Current | (Input pins) V _{CC} = Max. V _{IN} = V _{CC} (I/O pins) | | | 1 | μA |
| I _{IL} | Input LOW Current | (Input pins) V _{CC} = Max. V _{IN} = GND (I/O pins) | | | -1 | μA |
| I _{OZH} | High Impedance | V _{CC} = Max. V _{OUT} = 2.7V | | | 1 | μA |
| I _{OZL} | Output Current | | V _{OUT} = 0.5V | | | -1 |
| V _{IK} | Clamp Diode Voltage | V _{CC} = Min., I _{IN} = -18 mA | | -0.7 | -1.2 | V |
| I _{OS} | Short Circuit Current (I/O pins) | V _{CC} = Max. ⁽³⁾ , V _{OUT} = GND | -80 | -140 | -225 | mA |
| I _O | Output Drive Current (I/O pins) | V _{CC} = Max. ⁽³⁾ , V _{OUT} = 2.5V | -50 | | -180 | mA |
| I _{OFF} | Output Leakage Current (Open Drain) | V _{CC} = Max., V _{OUT} = 4.5V | | | ±100 | μA |
| V _H | Input Hysteresis | | | 100 | | mV |

PI74FCT16511T Output Drive Characteristics (Over the Operating Range)

| Parameters | Description | Test Conditions ⁽¹⁾ | Min. | Typ ⁽²⁾ | Max. | Units | |
|------------------|---------------------|--|----------------------------|--------------------|------|-------|---|
| V _{OH} | Output HIGH Voltage | V _{CC} = Min., V _{IN} = V _{IH} or V _{IL} | I _{OH} = -3.0 mA | 2.5 | 3.5 | | V |
| | | | I _{OH} = -15.0 mA | 2.4 | 3.5 | | |
| | | | I _{OH} = -32.0 mA | 2.0 | 3.0 | | |
| V _{OL} | Output LOW Voltage | V _{CC} = Min., V _{IN} = V _{IH} or V _{IL} | | 0.2 | 0.55 | V | |
| I _{OFF} | Power Down Disable | V _{CC} = 0V, V _{IN} or V _{OUT} ≤ 4.5V | — | — | ±100 | μA | |

PI74FCT162511T Output Drive Characteristics (Over the Operating Range)

| Parameters | Description | Test Conditions ⁽¹⁾ | Min. | Typ ⁽²⁾ | Max. | Units |
|------------------|---------------------|---|------|--------------------|------|-------|
| V _{OH} | Output HIGH Voltage | V _{CC} = Min., V _{IN} = V _{IH} or V _{IL} | | | | V |
| V _{OL} | Output LOW Voltage | V _{CC} = Min., V _{IN} = V _{IH} or V _{IL} | | 0.3 | 0.55 | V |
| I _{ODL} | Output LOW Current | V _{CC} = 5V, V _{IN} = V _{IH} or V _{IL} , V _{OUT} = 1.5V ⁽³⁾ | 60 | 115 | 150 | mA |
| I _{ODH} | Output HIGH Current | V _{CC} = 5V, V _{IN} = V _{IH} or V _{IL} , V _{OUT} = 1.5V ⁽³⁾ | -60 | -115 | -150 | mA |

Notes:

1. For Max. or Min. conditions, use appropriate value specified under Electrical Characteristics for the applicable device type.
2. Typical values are at V_{CC} = 5.0V, +25°C ambient and maximum loading.
3. Not more than one output should be shorted at one time. Duration of the test should not exceed one second.

Power Supply Characteristics

| Parameters | Description | Test Conditions ⁽¹⁾ | | Min. | Typ ⁽²⁾ | Max. | Units |
|------------------|---|--|---------------------------|------|--------------------|---------------------|------------|
| ICCL, ICCH, ICCZ | Quiescent Power Supply Current | VCC = Max. | VIN = GND or VCC | | 0.1 | 500 | μA |
| ΔICC | Supply Current per Input @ TTL HIGH | VCC = Max. | VIN = 3.4V ⁽³⁾ | | 0.5 | 1.5 | mA |
| ICCD | Supply Current per Input per MHz ⁽⁴⁾ | VCC = Max., Outputs Open OEAB = GND OEBA = VCC One Bit Toggling 50% Duty Cycle | VIN = VCC VIN = GND | | 75 | 120 | μA/ MHz |
| Ic | Total Power Supply Current ⁽⁶⁾ | VCC = Max., Outputs Open fCP = 10 MHz (CLKAB) 50% Duty Cycle LEAB = OEAB = GND OEBA = VCC fi = 5 MHz One Bit Toggling | VIN = VCC VIN = GND | | 0.8 | 1.7 ⁽⁵⁾ | mA |
| | | | VIN = 3.4V VIN = GND | | 1.3 | 3.2 ⁽⁵⁾ | |
| | | VCC = Max., Outputs Open fCP = 10 MHz (CLKAB) 50% Duty Cycle LEAB = OEAB = GND OEBA = VCC fi = 2.5 MHz 18 Bits Toggling | VIN = VCC VIN = GND | | 3.8 | 6.5 ⁽⁵⁾ | |
| | | | VIN = 3.4V VIN = GND | | 9.0 | 21.8 ⁽⁵⁾ | |

Notes:

- For Max. or Min. conditions, use appropriate value specified under Electrical Characteristics for the applicable device.
- Typical values are at VCC = 5.0V, +25°C ambient.
- Per TTL driven input (VIN = 3.4V); all other inputs at VCC or GND.
- This parameter is not directly testable, but is derived for use in Total Power Supply Calculations.
- Values for these conditions are examples of the ICC formula. These limits are guaranteed but not tested.
- IC = IQUIESCENT + IINPUTS + IDYNAMIC
 $IC = ICC + \Delta ICC \cdot D_{HNT} + ICCD (f_{CP}/2 + f_{INi})$
 ICC = Quiescent Current
 ΔICC = Power Supply Current for a TTL High Input (VIN = 3.4V)
 DH = Duty Cycle for TTL Inputs High
 NT = Number of TTL Inputs at DH
 ICCD = Dynamic Current Caused by an Input Transition Pair (HLH or LHL)
 fCP = Clock Frequency for Register Devices (Zero for Non-Register Devices)
 fi = Input Frequency
 Ni = Number of Inputs at fi
 All currents are in milliamps and all frequencies are in megahertz.

16511T/162511T Switching Characteristics over Operating Range (Propagation Delays)

| Parameters | Description | Conditions ⁽¹⁾ | 16511/162511T | | 162511AT | | Unit |
|---|--|---|---------------|------|----------|-----|------|
| | | | Com. | | Com. | | |
| | | | Min | Max | Min | Max | |
| t _{PLH} t _{PHL} | Propagation Delay P _{Ax} to P _{Bx} | C _L = 50 pF R _L = 500Ω | 1.5 | 6.5 | 1.5 | 5.7 | ns |
| t _{PLH} t _{PHL} | Propagation Delay A _x to B _x or B _x to A _x , P _{Bx} to P _{Ax} | | 1.5 | 6.5 | 1.5 | 5.0 | ns |
| t _{PLH} t _{PHL} | Propagation Delay A _x to P _{Bx} | | 1.5 | 9.0 | 1.5 | 7.5 | ns |
| t _{PLH} ⁽³⁾ t _{PHL} | Propagation Delay A _x to $\overline{\text{PERB}}$, P _{Ax} to $\overline{\text{PERB}}$ | | 1.5 | 10.5 | 1.5 | 9.0 | ns |
| | | | 1.5 | 9.5 | 1.5 | 8.0 | |
| t _{PLH} ⁽³⁾ t _{PHL} | Propagation Delay B _x to $\overline{\text{PERA}}$, P _{Bx} to $\overline{\text{PERA}}$ | | 1.5 | 10.5 | 1.5 | 9.0 | ns |
| | | | 1.5 | 9.5 | 1.5 | 8.0 | |
| t _{PLH} t _{PHL} | Propagation Delay LEBA to A _x and P _{Ax} LEAB to B _x and P _{Bx} | | 1.5 | 6.0 | 1.5 | 5.6 | ns |
| t _{PLH} ⁽³⁾ t _{PHL} | Propagation Delay LEBA to $\overline{\text{PERA}}$, LEAB to $\overline{\text{PERB}}$ | | 1.5 | 7.5 | 1.5 | 7.0 | ns |
| | | | 1.5 | 6.5 | 1.5 | 6.0 | |
| t _{PLH} t _{PHL} | Propagation Delay CLKBA to A _x and P _{Ax} CLKAB to B _x and P _{Bx} | | 1.5 | 6.0 | 1.5 | 5.6 | ns |
| t _{PLH} ⁽³⁾ t _{PHL} | Propagation Delay CLKBA to $\overline{\text{PERA}}$ CLKAB to $\overline{\text{PERB}}$ | | 1.5 | 7.5 | 1.5 | 7.0 | ns |
| | | | 1.5 | 6.5 | 1.5 | 6.0 | |
| t _{PZH} t _{PZL} | Output Enable Time $\overline{\text{OEBA}}$ to A _x and P _{Ax} $\overline{\text{OEAB}}$ to B _x and P _{Bx} | | 1.5 | 7.0 | 1.5 | 6.0 | ns |
| t _{PHZ} t _{PLZ} | Output Disable Time ⁽⁴⁾ $\overline{\text{OEBA}}$ to A _x and P _{Ax} $\overline{\text{OEAB}}$ to B _x and P _{Bx} | | 1.5 | 7.0 | 1.5 | 5.6 | ns |
| t _{PLZ} ⁽³⁾ t _{PZL} | Parity ERROR Enable $\overline{\text{OEBA}}$ to $\overline{\text{PERA}}$, $\overline{\text{OEAB}}$ to $\overline{\text{PERB}}$ | | 1.5 | 6.0 | 1.5 | 6.0 | ns |
| | | 1.5 | 6.0 | 1.5 | 6.0 | | |
| t _{PLH} t _{PHL} | ODD/ $\overline{\text{EVEN}}$ to $\overline{\text{PERB}}$ | 1.5 | 10.0 | 1.5 | 10.0 | ns | |
| | | 1.5 | 10.0 | 1.5 | 10.0 | | |
| t _{PLH} t _{PHL} | ODD/ $\overline{\text{EVEN}}$ to P _{Bx} | 1.5 | 10.0 | 1.5 | 10.0 | ns | |

Notes:

1. See test circuit and wave forms.
2. Minimum limits are guaranteed but not tested on Propagation Delays.
3. On Open Drain Outputs t_{PLH} is measured up to V_{OUT} = V_{OL} + 0.3V.
4. This parameter is guaranteed but not production tested.



PI74FCT16511T/162511T Switching Characteristics over Operating Range (Setup Times)

| Parameters | Description | Conditions ^(1,3) | | 16511/162511T | | 162511AT | | Unit |
|------------|---|---|----------------|---------------|------|----------|------|------|
| | | | | Com. | | Com. | | |
| | | | | Min. | Max. | Min. | Max. | |
| tsu | Setup Time HIGH or LOW Ax to CLKAB | $\overline{\text{GEN}}/\text{CHK LOW}$ | PBx valid | 6.5 | — | 4 | — | ns |
| | | | PBx not valid | 3 | — | 3 | — | ns |
| | | $\overline{\text{GEN}}/\text{CHK HIGH}$ | PERB valid | 6.5 | — | 4 | — | ns |
| | | | PERB not valid | 3 | — | 3 | — | ns |
| tsu | Setup Time PAX to CLKAB | $\overline{\text{GEN}}/\text{CHK HIGH}$ | PERB valid | 6.5 | — | 4 | — | ns |
| | | | PERB not valid | 3 | — | 3 | — | ns |
| tsu | Setup Time Bx to CLKBA PBx to CLKBA | | PERA valid | 6.5 | — | 4 | — | ns |
| | | | PERA not valid | 3 | — | 3 | — | ns |
| tsu | Setup Time Ax to LEAB | CLKAB LOW | PBx valid | 6.5 | — | 3.5 | — | ns |
| | | | PBx not valid | 3 | — | 3 | — | ns |
| | | $\overline{\text{GEN}}/\text{CHK LOW}$ | PERB valid | 6.5 | — | 3.5 | — | ns |
| | | | PERB not valid | 3 | — | 3 | — | ns |
| | | CLKAB HIGH | PBx valid | 6.5 | — | 3.5 | — | ns |
| | | | PBx not valid | 3 | — | 3 | — | ns |
| | | $\overline{\text{GEN}}/\text{CHK HIGH}$ | PERB valid | 6.5 | — | 3.5 | — | ns |
| | | | PERB not valid | 3 | — | 3 | — | ns |
| tsu | Setup Time PAX to LEAB | CLKAB LOW | PERB valid | 6.5 | — | 3.5 | — | ns |
| | | | PERB not valid | 3 | — | 3 | — | ns |
| | | CLKAB HIGH | PERB valid | 6.5 | — | 3.5 | — | ns |
| | | | PERB not valid | 3 | — | 3 | — | ns |
| tsu | Setup Time Bx to LEBA PBx to LEBA | CLKBA LOW | PERA valid | 6.5 | — | 3.5 | — | ns |
| | | | PERA not valid | 3 | — | 3 | — | ns |
| | | CLKAB HIGH | PERA valid | 6.5 | — | 3.5 | — | ns |
| | | | PERA not valid | 3 | — | 3 | — | ns |

CL = 50 pF
 RL = 500Ω

PI74FCT16511T/162511T Switching Characteristics over Operating Range (Hold Times)

| Parameters | Description | Conditions ⁽¹⁾ | 16511/162511T | | 162511AT | | Unit |
|------------|---|---------------------------|---------------|------|----------|------|------|
| | | | Com. | | Com. | | |
| | | | Min. | Max. | Min. | Max. | |
| th | Hold Time HIGH or LOW Ax to LEAB, Bx to LEBA | CL = 50 pF RL = 500Ω | 1 | — | 1 | — | ns |
| th | Hold Time HIGH or LOW PAX to LEAB | | 1 | — | 1 | — | ns |
| th | Hold Time HIGH or LOW PBx to LEBA | | 1 | — | 1 | — | ns |
| th | Hold Time Ax to CLKAB, PAX to CLKAB | | 1 | — | 1 | — | ns |
| th | Hold Time Bx to CLKBA, PBx to CLKBA | | 1 | — | 1 | — | ns |
| tw | LEAB or LEBA Pulse Width HIGH ⁽²⁾ | | 3 | — | 3 | — | ns |
| tw | CLKAB or CLKBA Pulse Width HIGH or LOW ⁽²⁾ | | 3 | — | 3 | — | ns |

Notes:

- See test circuit and wave forms.
- This parameter is guaranteed but not production tested.
- “Not valid” means the setup time indicated is not sufficient to assure proper functioning of this output; however, the set-up time indicated will assure proper functioning of the A-to-B or B-to-A port respective to the indicated direction.

Pericom Semiconductor Corporation

2380 Bering Drive • San Jose, CA 95131 • 1-800-435-2336 • Fax (408) 435-1100 • <http://www.pericom.com>