



**PI74FCT240T/241T/
244T/540T/541T (25 ohm Series)
PI74FCT2240T/2241T/2244T/2541T**

**Fast CMOS Octal
Buffer/Line Drivers**

Product Features

- PI74FCT240/241/244/540/541T and PI74FCT2240/2241/2244/2541T are pin compatible with bipolar FAST™ Series at a higher speed and lower power consumption
- 25Ω series resistor on all outputs (FCT2XXX only)
- TTL input and output levels
- Low ground bounce outputs
- Extremely low static power
- Hysteresis on all inputs
- Industrial operating temperature range: -40°C to +85°C
- Packages available:
 - 20-pin 173 mil wide plastic TSSOP (L)
 - 20-pin 209 mil wide plastic SSOP (H)
 - 20-pin 300 mil wide plastic DIP (P)
 - 20-pin 150 mil wide plastic QSOP (Q)
 - 20-pin 150 mil wide plastic TQSOP (R)
 - 20-pin 300 mil wide plastic SOIC (S)
- Device models available upon request

Product Description

Pericom Semiconductor's PI74FCT series of logic circuits are produced in the Company's advanced 0.6/0.8 micron CMOS technology, achieving industry leading speed grades. All PI74FCT2XXX devices have a built-in 25 ohm series resistor on all outputs to reduce noise because of reflections, thus eliminating the need for an external terminating resistor.

The PI74FCT240T/241T/244T/540T/541T and PI74FCT2240T/2241T/2244/2541T are 8-bit wide driver circuits, designed to be used in applications requiring high-speed and high-output drive. Ideal applications would include bus drivers, memory drivers, address drivers, and system clock drivers.

The PI74FCT540T and PI74FCT541/2541T provide similar driver capabilities, but have their pins physically grouped by function. All inputs are located on one side of the package, while outputs are on the opposite side, allowing for a much simpler and denser board layout.

Logic Block Diagrams

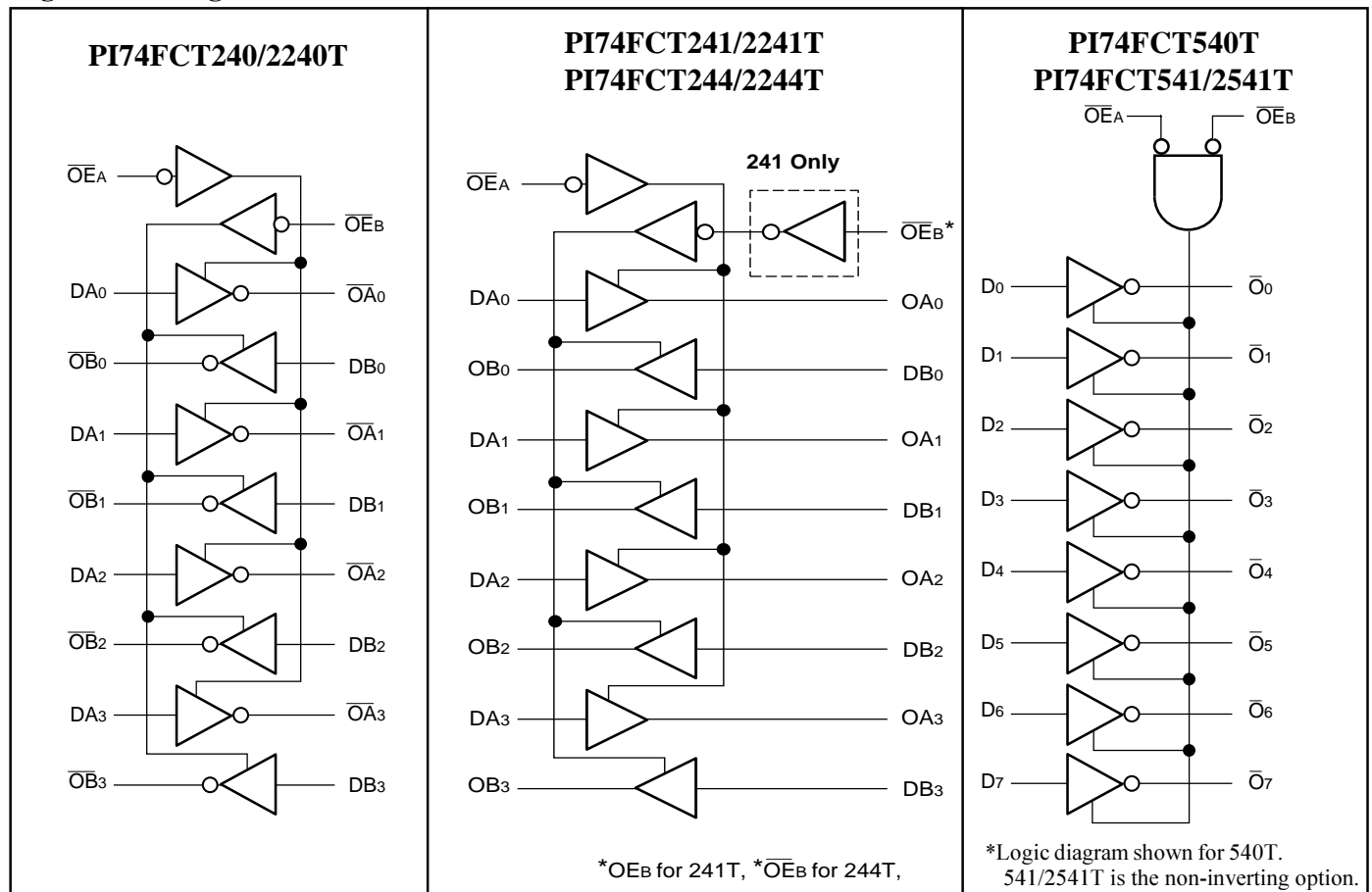

Product Pin Description

Pin Name	Description
$\overline{\text{OEA}}, \overline{\text{OEB}}$	3-State Output Enable Inputs (Active LOW)
$\text{OEB}^{(1)}$	3-State Output Enable Input (Active HIGH)
Dxx	Inputs
Oxx	Outputs
GND	Ground
Vcc	Power

Truth Table

Inputs ⁽¹⁾				Outputs ⁽¹⁾				
$\overline{\text{OEA}}$	$\overline{\text{OEB}}$	$\text{OEB}^{(2)}$	D	240	241	244	540	541
L	L	H	L	H	L	L	H	L
L	L	H	H	L	H	H	L	H
H	H	L	X	Z	Z	Z	Z	Z

Note:

- H = High Voltage Level, X = Don't Care, L = Low Voltage Level, Z = High Impedance
- OEB for 241 only.

PI74FCT240/2240T Product Pin Configuration

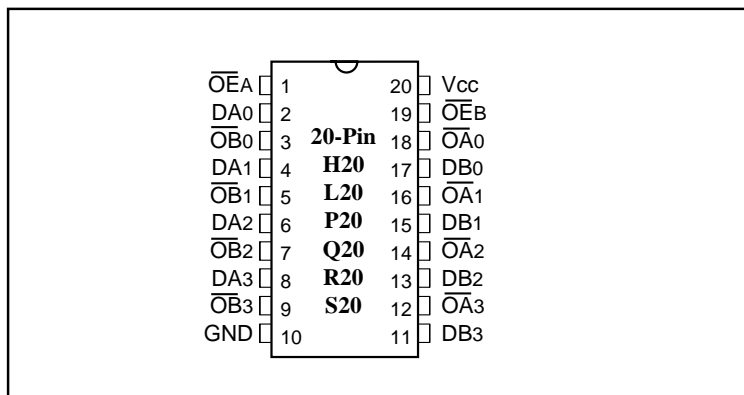

PI74FCT241/2241/244/2244T Product Pin Configuration

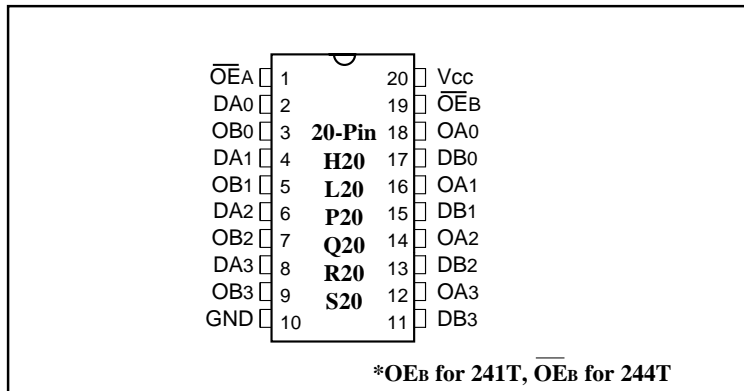

PI74FCT540/541/2541T Product Pin Configuration

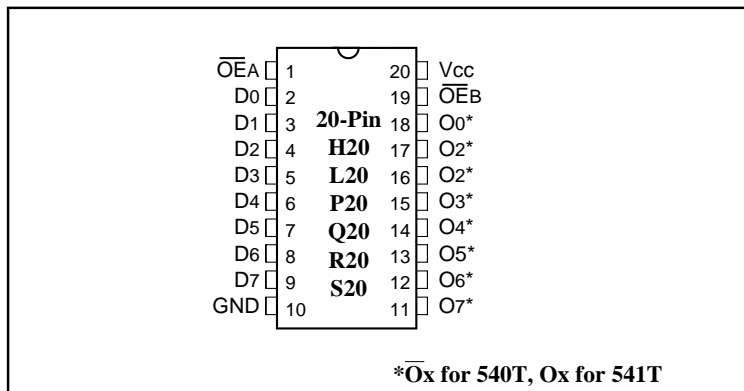



Maximum Ratings

(Above which the useful life may be impaired. For user guidelines, not tested.)

Storage Temperature	-65°C to +150°C	Note: Stresses greater than those listed under MAXIMUM RATINGS may cause permanent damage to the device. This is a stress rating only and functional operation of the device at these or any other conditions above those indicated in the operational sections of this specification is not implied. Exposure to absolute maximum rating conditions for extended periods may affect reliability.
Ambient Temperature with Power Applied	-40°C to +85°C	
Supply Voltage to Ground Potential (Inputs & Vcc Only)	-0.5V to +7.0V	
Supply Voltage to Ground Potential (Outputs & D/O Only) .	-0.5V to +7.0V	
DC Input Voltage	-0.5V to +7.0V	
DC Output Current	120mA	
Power Dissipation	0.5W	

DC Electrical Characteristics (Over the Operating Range, TA = -40°C to +85°C, VCC = 5.0V ± 5%)

Parameters	Description	Test Conditions ⁽¹⁾	Min.	Typ ⁽²⁾	Max.	Units
VOH	Output HIGH Voltage	VCC = Min., VIN = VIH or VIL IOH = -15.0mA	2.4	3.0		V
VOL	Output LOW Current	VCC = Min., VIN = VIH or VIL IOL = 64mA		0.3	0.55	V
VOL	Output LOW Current	VCC = Min., VIN = VIH or VIL IOL = 12mA (25ΩSeries)		0.3	0.50	V
VIH	Input HIGH Voltage	Guaranteed Logic HIGH Level	2.0			V
VIL	Input LOW Voltage	Guaranteed Logic LOW Level			0.8	V
IiH	Input HIGH Current	VCC = Max. VIN = VCC			1	μA
IiL	Input LOW Current	VCC = Max. VIN = GND			-1	μA
IOZH	High Impedance	VCC = MAX. VOUT = 2.7V			1	μA
IOZL	Output Current	VCC = MAX. VOUT = 0.5V			-1	μA
Vik	Clamp Diode Voltage	VCC = Min., IIN = -18mA		-0.7	-1.2	V
IOFF	Power Down Disable	VCC = GND, VOUT = 4.5V	—	—	100	μA
Ios	Short Circuit Current	VCC = Max. ⁽³⁾ , VOUT = GND	-60	-120		mA
VH	Input Hysteresis			200		mV

Capacitance (TA = 25°C, f = 1 MHz)

Parameters ⁽⁴⁾	Description	Test Conditions	Typ	Max.	Units
CIN	Input Capacitance	VIN = 0V	6	10	pF
COUT	Output Capacitance	VOUT = 0V	8	12	pF

Notes:

1. For Max. or Min. conditions, use appropriate value specified under Electrical Characteristics for the applicable device type.
2. Typical values are at Vcc = 5.0V, +25°C ambient and maximum loading.
3. Not more than one output should be shorted at one time. Duration of the test should not exceed one second.
4. This parameter is determined by device characterization but is not production tested.

Power Supply Characteristics

Parameters	Description	Test Conditions ⁽¹⁾		Min.	Typ ⁽²⁾	Max.	Units
I _{CC}	Quiescent Power Supply Current	V _{CC} = Max.	V _{IN} = GND or V _{CC}		0.1	500	μA
ΔI _{CC}	Supply Current per Input @ TTL HIGH	V _{CC} = Max.	V _{IN} = 3.4V ⁽³⁾		0.5	2.5	mA
I _{CCD}	Supply Current per Input per MHz ⁽⁴⁾	V _{CC} = Max., Outputs Open $\overline{OE}_A = \overline{OE}_B = \text{GND}$ or $\overline{OE}_A = \text{GND}, \overline{OE}_B = \text{VCC}$ One Bit Toggling 50% Duty Cycle	V _{IN} = V _{CC} V _{IN} = GND		0.15	0.25	mA/ MHz
I _C	Total Power Supply Current ⁽⁶⁾	V _{CC} = Max., Outputs Open f _i = 10 MHz 50% Duty Cycle $\overline{OE}_A = \overline{OE}_B = \text{GND}$ or $\overline{OE}_A = \text{GND}, \overline{OE}_B = \text{VCC}$ One Bit Toggling	V _{IN} = V _{CC} V _{IN} = GND		1.5	3.5 ⁽⁵⁾	mA
			V _{IN} = 3.4V V _{IN} = GND		1.8	4.5 ⁽⁵⁾	
		V _{CC} = Max., Outputs Open f _i = 2.5 MHz 50% Duty Cycle $\overline{OE}_A = \overline{OE}_B = \text{GND}$ or $\overline{OE}_A = \text{GND}, \overline{OE}_B = \text{VCC}$ Eight Bits Toggling	V _{IN} = V _{CC} V _{IN} = GND		3.0	6.0 ⁽⁵⁾	
			V _{IN} = 3.4V V _{IN} = GND		5.0	14.0 ⁽⁵⁾	

Notes:

- For Max. or Min. conditions, use appropriate value specified under Electrical Characteristics for the applicable device.
- Typical values are at V_{CC} = 5.0V, +25°C ambient.
- Per TTL driven input (V_{IN} = 3.4V); all other inputs at V_{CC} or GND.
- This parameter is not directly testable, but is derived for use in Total Power Supply Calculations.
- Values for these conditions are examples of the I_{CC} formula. These limits are guaranteed but not tested.

$$I_C = I_{\text{QUIESCENT}} + I_{\text{INPUTS}} + I_{\text{DYNAMIC}}$$

$$I_C = I_{\text{CC}} + \Delta I_{\text{CC}} D_H N_T + I_{\text{CCD}} (f_{\text{CP}}/2 + f_i N_i)$$

I_{CC} = Quiescent Current

ΔI_{CC} = Power Supply Current for a TTL High Input (V_{IN} = 3.4V)

D_H = Duty Cycle for TTL Inputs High

N_T = Number of TTL Inputs at D_H

I_{CCD} = Dynamic Current Caused by an Input Transition Pair (HLH or LHL)

f_{CP} = Clock Frequency for Register Devices (Zero for Non-Register Devices)

f_i = Input Frequency

N_i = Number of Inputs at f_i

All currents are in milliamperes and all frequencies are in megahertz.

PI74FCT240/2240T Switching Characteristics over Operating Range

Parameters	Description	Conditions ⁽¹⁾	240T/2240T		240AT/2240AT		240CT/2240CT		240DT		Units
			Com.		Com.		Com.		Com.		
			Min	Max	Min	Max	Min	Max	Min	Max	
tPLH	Propagation Delay DN to ON	CL = 50pF RL = 500Ω	1.5	8.0	1.5	4.8	1.5	4.3	1.5	3.6	ns
tPHL			1.5	10.0	1.5	6.2	1.5	5.8	1.5	4.8	ns
tpZH	Output Enable Time OEX to ON		1.5	9.5	1.5	5.6	1.5	5.2	1.5	4.0	ns
tpZL	Output Disable Time ⁽³⁾ OEX to ON										

PI74FCT241/2241T Switching Characteristics over Operating Range

Parameters	Description	Conditions ⁽¹⁾	241T/2241T		241AT/2241AT		241CT/2241CT		241DT		Units
			Com.		Com.		Com.		Com.		
			Min	Max	Min	Max	Min	Max	Min	Max	
tPLH	Propagation Delay DN to ON	CL = 50pF RL = 500Ω	1.5	6.5	1.5	4.8	1.5	4.1	1.5	3.6	ns
tPHL			1.5	8.0	1.5	6.2	1.5	5.8	1.5	4.8	ns
tpZH	Output Enable Time OEA/OEB to ON		1.5	7.0	1.5	5.6	1.5	5.2	1.5	4.0	ns
tpZL	Output Disable Time ⁽³⁾ OEA/OEB to ON										

PI74FCT244/2244T Switching Characteristics over Operating Range

Parameters	Description	Conditions ⁽¹⁾	244T/2244T		244AT/2244AT		244CT/2244CT		244DT		Units
			Com.		Com.		Com.		Com.		
			Min	Max	Min	Max	Min	Max	Min	Max	
tPLH	Propagation Delay DN to ON	CL = 50pF RL = 500Ω	1.5	6.5	1.5	4.8	1.5	4.1	1.5	3.6	ns
tPHL			1.5	8.0	1.5	6.2	1.5	5.8	1.5	4.8	ns
tpZH	Output Enable Time OEX to ON		1.5	7.0	1.5	5.6	1.5	5.2	1.5	4.0	ns
tpZL	Output Disable Time ⁽³⁾ OEX to ON										

Notes:

1. See test circuit and wave forms.
2. Minimum limits are guaranteed but not tested on Propagation Delays.
3. This parameter is guaranteed but not production tested.



PI74FCT540T Switching Characteristics over Operating Range

Parameters	Description	Conditions ⁽¹⁾	540T		540AT		540CT		540DT		Units
			Com.		Com.		Com.		Com.		
			Min	Max	Min	Max	Min	Max	Min	Max	
tPLH tPHL	Propagation Delay DN to $\bar{O}N$	CL = 50pF RL = 500Ω	1.5	5.5	1.5	4.8	1.5	4.3	1.5	3.8	ns
tpZH tpZL	Output Enable Time $\bar{O}E_x$ to $\bar{O}N$		1.5	10.0	1.5	6.2	1.5	5.8	1.5	5.2	ns
tPHZ tPLZ	Output Disable Time ⁽³⁾ $\bar{O}E_x$ to $\bar{O}N$		1.5	6.0	1.5	5.6	1.5	5.2	1.5	5.2	ns

PI74FCT541/2541T Switching Characteristics over Operating Range

Parameters	Description	Conditions ⁽¹⁾	541T/2541T		541AT/2541AT		541CT/2541CT		541DT		Units
			Com.		Com.		Com.		Com.		
			Min	Max	Min	Max	Min	Max	Min	Max	
tPLH tPHL	Propagation Delay DN to $\bar{O}N$	CL = 50pF RL = 500Ω	1.5	6.0	1.5	4.8	1.5	4.1	1.5	3.8	ns
tpZH tpZL	Output Enable Time $\bar{O}E_x$ to $\bar{O}N$		1.5	9.5	1.5	6.2	1.5	5.8	1.5	5.2	ns
tPHZ tPLZ	Output Disable Time ⁽³⁾ $\bar{O}E_x$ to $\bar{O}N$		1.5	6.5	1.5	5.6	1.5	5.2	1.5	5.2	ns

Notes:

1. See test circuit and wave forms.
2. Minimum limits are guaranteed but not tested on Propagation Delays.
3. This parameter is guaranteed but not production tested.