

Fast CMOS 3.3V 16-Bit Registered Transceivers

Product Features

- Compatible with LCX™ and LVT™ families of products
- Supports 5V Tolerant Mixed Signal Mode Operation
 - Input can be 3V or 5V
 - Output can be 3V or connected to 5V bus
- Advanced Low Power CMOS Operation
- Excellent output drive capability:
Balanced drives (24 mA sink and source)
- Pin compatible with industry standard double-density pinouts
- Low ground bounce outputs
- Hysteresis on all inputs
- Industrial operating temperature range: -40°C to +85°C
- Multiple center pins and distributed Vcc/GND pins minimize switching noise
- Packages available:
 - 56-pin 240 mil wide plastic TSSOP (A)
 - 56-pin 300 mil wide plastic SSOP (V)

Product Description

Pericom Semiconductor's PI74LPT series of logic circuits are produced in the Company's advanced 0.6 micron CMOS technology, achieving industry leading speed grades.

The PI74LPT16952 is a 16-bit registered transceivers organized with two sets of eight D-type latches with separate input and output controls for each set. For data flow from A to B, for example, the A-to-B Enable (xCEAB) input must be LOW to enter data from xAx. The data present on the A port will be clocked on the B register when xCLKAB toggles from LOW-to-HIGH. The xOEAB control performs the output enable function on the B port. Control of data from B to A is similar, but uses the xCEAB, xCLKAB, and xOEAB inputs. By connecting the control pins of the two independent transceivers together, a full 16-bit operation can be achieved. The output buffers are designed with a Power-Off disable allowing "live insertion" of boards when used as backplane drivers.

The PI74LPT16952 can be driven from either 3.3V or 5.0V devices allowing this device to be used as a translator in a mixed 3.3/5.0V system.

Logic Block Diagram

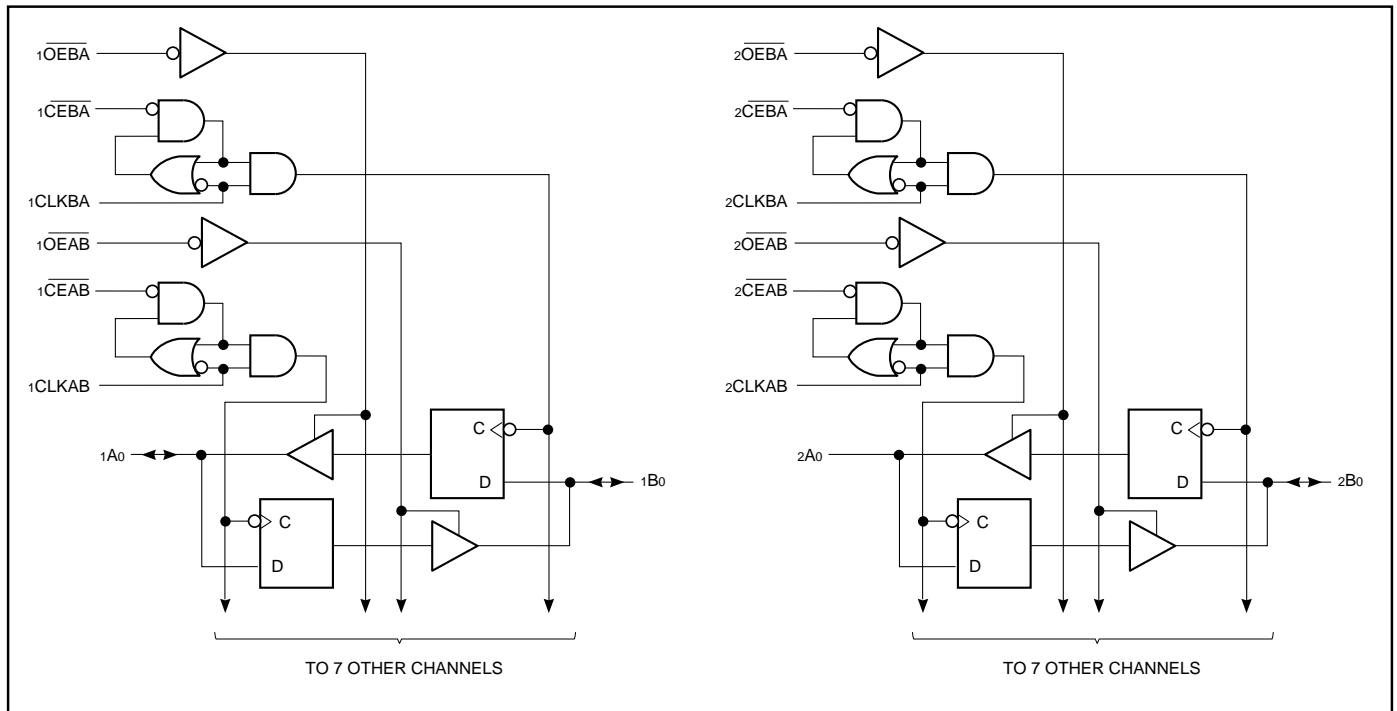

Product Pin Description

Pin Name	Description
x \overline{OEAB}	A-to-B Output Enable Input (Active LOW)
x \overline{OEBA}	B-to-A Output Enable Input (Active LOW)
x \overline{CEAB}	A-to-B Clock Enable Input (Active LOW)
x \overline{CEBA}	B-to-A Clock Enable Input (Active LOW)
xCLKAB	A-to-B Clock Input
xCLKBA	B-to-A Clock Input
xAx	A-to-B Data Inputs or B-to-A 3-State Outputs
xBx	B-to-A Data Inputs or B-to-A 3-State Outputs
GND	Ground
VCC	Power

Truth Table^(1,2)

Inputs				Outputs
x \overline{CEAB}	xCLKAB	x \overline{OEAB}	xAx	xBx
H	X	L	X	B ⁽³⁾
X	L	L	X	B ⁽³⁾
L	↑	L	L	L
L	↑	L	H	H
X	X	H	X	High Z

Notes:

- H = High Voltage Level
L = Low Voltage Level
X = Don't Care or Irrelevant
↑ = LOW-to-HIGH Transition
Z = High Impedance
- A-to-B data flow shown. B-to-A flow control is the same, except using xCEBA, xCLKBA, and xOEBA.
- Level of B before the indicated steady-state input conditions were established.

Product Pin Configuration

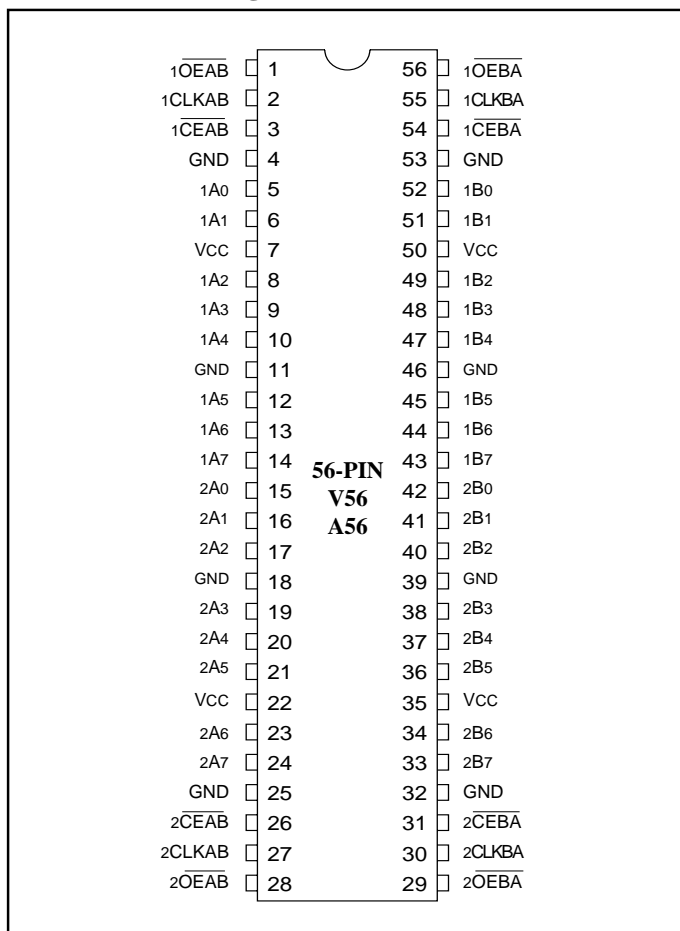

Maximum Ratings

(Above which the useful life may be impaired. For user guidelines, not tested.)

Storage Temperature	-55°C to +125°C
Ambient Temperature with Power Applied	-40°C to +85°C
Supply Voltage to Ground Potential (Inputs & V _{CC} Only)	-0.5V to +7.0V
Supply Voltage to Ground Potential (Outputs & D/O Only) ..	-0.5V to +7.0V
DC Input Voltage	-0.5V to +7.0V
DC Output Current	120 mA
Power Dissipation	1.0W

Note:

Stresses greater than those listed under MAXIMUM RATINGS may cause permanent damage to the device. This is a stress rating only and functional operation of the device at these or any other conditions above those indicated in the operational sections of this specification is not implied. Exposure to absolute maximum rating conditions for extended periods may affect reliability.

DC Electrical Characteristics (Over the Operating Range, T_A = -40°C to +85°C, V_{CC} = 2.7V to 3.6V)

Parameters	Description	Test Conditions ⁽¹⁾		Min.	Typ ⁽²⁾	Max.	Units
V _{IH}	Input HIGH Voltage (Input pins)	Guaranteed Logic HIGH Level		2.2	—	5.5	V
	Input HIGH Voltage (I/O pins)			2.0	—	5.5	V
V _{IL}	Input LOW Voltage (Input and I/O pins)	Guaranteed Logic LOW Level		-0.5	—	0.8	V
I _{IH}	Input HIGH Current (Input pins)	V _{CC} = Max.	V _{IN} = 5.5V	—	—	±1	µA
	Input HIGH Current (I/O pins)	V _{CC} = Max.	V _{IN} = V _{CC}	—	—	±1	µA
I _{IL}	Input LOW Current (Input pins)	V _{CC} = Max.	V _{IN} = GND	—	—	±1	µA
	Input LOW Current (I/O pins)	V _{CC} = Max.	V _{IN} = GND	—	—	±1	µA
I _{OZH}	High Impedance Output Current (3-State Output pins)	V _{CC} = Max.	V _{OUT} = 5.5V	—	—	±1	µA
I _{OZL}		V _{CC} = Max.	V _{OUT} = GND	—	—	±1	µA
V _{IK}	Clamp Diode Voltage	V _{CC} = Min., I _{IN} = -18 mA		—	-70	-1.2	V
I _{ODH}	Output HIGH Current	V _{CC} = 3.3V, V _{IN} = V _{IH} or V _{IL} , V _O = 1.5V ⁽³⁾		-36	-60	-110	mA
I _{ODL}	Output LOW Current	V _{CC} = 3.3V, V _{IN} = V _{IH} or V _{IL} , V _O = 1.5V ⁽³⁾		50	90	200	mA
V _{OH}	Output HIGH Voltage	V _{CC} = Min.	I _{OH} = -0.1 mA	V _{CC} -0.2	—	—	V
		V _{IN} = V _{IH} or V _{IL}	I _{OH} = -3 mA	2.4	3.0	—	V
		V _{CC} = 3.0V	I _{OH} = -8 mA	2.4 ⁽⁵⁾	3.0	—	V
		V _{IN} = V _{IH} or V _{IL}	I _{OH} = -24 mA	2.0	—	—	V
V _{OL}	Output LOW Voltage	V _{CC} = Min.	I _{OL} = 0.1 mA	—	—	0.2	V
			I _{OL} = 16 mA	—	0.2	0.4	V
			I _{OL} = 24 mA	—	0.3	0.5	V
I _{OS}	Short Circuit Current ⁽⁴⁾	V _{CC} = Max. ⁽³⁾ , V _{OUT} = GND		-60	-85	-240	mA
I _{OFF}	Power Down Disable	V _{CC} = 0V, V _{IN} or V _{OUT} ≤ 4.5V		—	—	±100	µA
V _H	Input Hysteresis			—	150	—	mV

Notes:

1. For Max. or Min. conditions, use appropriate value specified under Electrical Characteristics for the applicable device type.
2. Typical values are at V_{CC} = 3.3V, +25°C ambient and maximum loading.
3. Not more than one output should be shorted at one time. Duration of the test should not exceed one second.
4. This parameter is guaranteed but not tested.
5. V_{OH} = V_{CC} - 0.6V at rated current.

Power Supply Characteristics

Parameters	Description	Test Conditions ⁽¹⁾		Min.	Typ ⁽²⁾	Max.	Units
I _{CC}	Quiescent Power Supply Current	V _{CC} = Max.	V _{IN} = GND or V _{CC}		0.1	10	μA
ΔI _{CC}	Quiescent Power Supply Current TTL Inputs HIGH	V _{CC} = Max.	V _{IN} = V _{CC} - 0.6V ⁽³⁾		2.0	30	μA
I _{CCD}	Dynamic Power Supply ⁽⁴⁾	V _{CC} = Max., Outputs Open x \overline{OE} = GND One Bit Toggling 50% Duty Cycle	V _{IN} = V _{CC} V _{IN} = GND		50	75	μA/ MHz
I _C	Total Power Supply Current ⁽⁶⁾	V _{CC} = Max., Outputs Open f _i = 10 MHz 50% Duty Cycle x \overline{OE} = GND One Bit Toggling	V _{IN} = V _{CC} - 0.6V V _{IN} = GND		0.6	2.3	mA
		V _{CC} = Max., Outputs Open f _i = 2.5 MHz 50% Duty Cycle x \overline{OE} = GND 16 Bits Toggling	V _{IN} = V _{CC} - 0.6V V _{IN} = GND		2.1	4.7 ⁽⁵⁾	

Notes:

- For Max. or Min. conditions, use appropriate value specified under Electrical Characteristics for the applicable device.
- Typical values are at V_{CC} = 3.3V, +25°C ambient.
- Per TTL driven input; all other inputs at V_{CC} or GND.
- This parameter is not directly testable, but is derived for use in Total Power Supply Calculations.
- Values for these conditions are examples of the I_{CC} formula. These limits are guaranteed but not tested.
- I_C = I_{QUIESCENT} + I_{INPUTS} + I_{DYNAMIC}
 $I_C = I_{CC} + \Delta I_{CC} D_H N_T + I_{CCD} (f_{CP}/2 + f_i N_i)$
 I_{CC} = Quiescent Current (I_{CC1}, I_{CC2} and I_{CCZ})
 ΔI_{CC} = Power Supply Current for a TTL High Input
 D_H = Duty Cycle for TTL Inputs High
 N_T = Number of TTL Inputs at D_H
 I_{CCD} = Dynamic Current Caused by an Input Transition Pair (HLH or LHL)
 f_{CP} = Clock Frequency for Register Devices (Zero for Non-Register Devices)
 N_{CP} = Number of Clock Inputs at f_{CP}
 f_i = Input Frequency
 N_i = Number of Inputs at f_i
 All currents are in milliamps and all frequencies are in megahertz.

Switching Characteristics over Operating Range⁽¹⁾

Parameters	Description	Conditions ⁽²⁾	LPT16952A		LPT16952B		LPT16952C		Units
			Com.		Com.		Com.		
			Min. ⁽³⁾	Max.	Min. ⁽³⁾	Max.	Min. ⁽³⁾	Max.	
t _{PLH} t _{PHL}	Propagation Delay xCLKAB, xCLKBA to xBx, xAx	C _L = 50 pF R _L = 500Ω	2.0	10.0	2.0	7.5	2.0	6.3	ns
t _{PZH} t _{PZL}	Output Enable Time xOEBA, xOEAB to xAx, xBx		1.5	10.5	1.5	8.0	1.5	7.0	ns
t _{PHZ} t _{PLZ}	Output Disable Time ⁽⁴⁾ xOEBA, xOEAB to xAx, xBx		1.5	10.0	1.5	7.5	1.5	6.5	ns
t _{SU}	Set-up Time HIGH or LOW xAx, xBx to xCLKAB, xCLKBA		2.5	—	2.5	—	2.5	—	ns
t _H	Hold Time HIGH or LOW xAx, xBx to xCLKAB, xCLKBA		2.0	—	2.0	—	2.0	—	ns
t _{SU}	Setup Time HIGH or LOW xCEAB, xCEBA to xCLKAB, xCLKBA		3.0	—	3.0	—	3.0	—	ns
t _H	Hold Time HIGH or LOW xCEAB, xCEBA to xCLKAB, xCLKBA		2.0	—	2.0	—	2.0	—	ns
t _w	Pulse Width HIGH ⁽⁴⁾ or LOW, xCLKAB or xCLKBA		3.0	—	3.0	—	3.0	—	ns
t _{SK(0)}	Output Skew ⁽⁵⁾		—	0.5	—	0.5	—	0.5	ns

Notes:

1. Propagation Delays and Enable/Disable times are with V_{CC} = 3.3V ±0.3V, normal range. For V_{CC} = 2.7V, extended range, all Propagation Delays and Enable/Disable times should be degraded by 20%.
2. See test circuit and wave forms.
3. Minimum limits are guaranteed but not tested on Propagation Delays.
4. This parameter is guaranteed but not production tested.
5. Skew between any two outputs, of the same package, switching in the same direction. This parameter is guaranteed by design.

Capacitance (T_A = 25°C, f = 1 MHz)

Parameters ⁽¹⁾	Description	Test Conditions	Typ.	Max.	Units
C _{IN}	Input Capacitance	V _{IN} = 0V	4.5	6	pF
C _{OUT}	Output Capacitance	V _{OUT} = 0V	5.5	8	pF

Note:

1. This parameter is determined by device characterization but is not production tested.

Pericom Semiconductor Corporation

 2380 Bering Drive • San Jose, CA 95131 • 1-800-435-2336 • Fax (408) 435-1100 • <http://www.pericom.com>