

**Features**

- High-speed:  $t_{PD} = 1.8\text{ns}$  typical
- Broad operating range:  $V_{CC} = 1.8\text{V} - 3.6\text{V}$
- Power down high-impedance inputs/outputs
- High output drive:  $\pm 24\text{mA}$  at  $3\text{V } V_{CC}$
- Package: 5-pin space saving SOT23 and SC70

**Description**

The PI74ST1G125 is a buffer with 3-state output that operates over the 1.8V to 3.6V  $V_{CC}$  operating range.

Pericom's PI74ST series of products are produced using the Company's advanced submicron technology.

**Pinout**

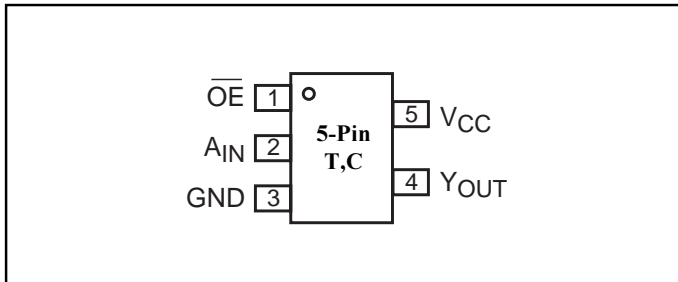

**Block Diagram**

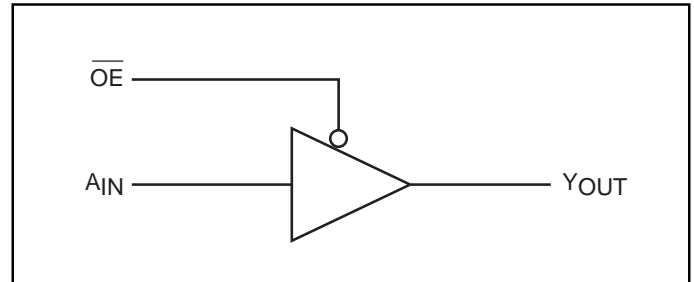

**Pin Description**

Pin Names	Description
$A_{IN}$	Input
$\overline{OE}$	Input
$Y_{OUT}$	Output

**Recommended Operating Conditions<sup>(1)</sup>**

Parameter	Condition	Min.	Max.	Units
Supply Voltage ( $V_{CC}$ )		1.8	3.6	V
Input Voltage ( $V_{IN}$ )		0	5.5	
Output Voltage ( $V_{OUT}$ )		0	$V_{CC}$	
Operating Temperature		-40	85	°C
Input Rise and Fall Time ( $t_r, t_f$ )	$V_{CC} = 1.8\text{V}, 2.5\text{V} \pm 0.2\text{V}$	0	20	ns/V
	$V_{CC} = 3.3\text{V}, \pm 0.3\text{V}$	0	10	

**Function Table**

Inputs		Output
$\overline{OE}$	$A_{IN}$	$Y_{OUT}$
L	L	L
L	H	H
H	X	Z

**Note:**

1. Unused inputs must be held HIGH or LOW. They may not float.

**Notes:**

- H = HIGH Logic Level
- L = LOW Logic Level
- X = Don't Care
- Z = HIGH Impedance State

### Absolute Maximum Ratings

Supply Voltage ( $V_{CC}$ )	-0.5V to +4V
DC Input Voltage ( $V_{IN}$ )	-0.5V to +6V
DC Output Voltage ( $V_{OUT}$ )	-0.5V to +6V
DC Input Diode Current ( $I_{IK}$ )	-50mA to 20mA
DC Output Diode Current ( $I_{OK}$ )	-50mA to 20mA
DC Output Current ( $I_{OUT}$ )	±50mA
DC $V_{CC}/GND$ Current ( $I_{CC}/I_{GND}$ )	±50mA
Storage Temperature ( $T_{STG}$ )	-65°C to +150°C
Junction Lead Temperature (IOS)	200°C
Power Dissipation	SOT23 ..... 200mW SC70 ..... 150mW

**Note:**

Absolute maximum ratings are DC values beyond which the device may be damaged or have its useful life impaired. The datasheet specifications should be met, without exception, to ensure that the system design is reliable over its power supply, temperature, and output/input loading variables. Pericom does not recommend operation outside datasheet specifications.

### DC Electrical Characteristics (Over supply voltage and operating temperature ranges, unless otherwise specified)

Symbol	Parameter	$V_{CC}$ (V)	Conditions	$T_A = +25^\circ\text{C}$			$T_A = -40^\circ\text{C}$ to $+85^\circ\text{C}$		Units	
				Min.	Typ.	Max.	Min.	Max.		
$V_{IH}$	HIGH Level Input Voltage	1.8 2.3-3.6		0.75 $V_{CC}$ 0.70 $V_{CC}$			0.75 $V_{CC}$ 0.70 $V_{CC}$			
$V_{IL}$	LOW Level Input Voltage	1.8 2.3-3.6				0.25 $V_{CC}$ 0.30 $V_{CC}$		0.25 $V_{CC}$ 0.30 $V_{CC}$		
$V_{OH}$	HIGH Level Output Voltage	1.8	$V_{IN} = V_{IH}$	$I_{OH} = -100\mu\text{A}$	1.7	1.79		1.7		V
		2.3			2.2	2.29		2.2		
		3.0			2.9	2.99		2.9		
		2.3		$I_{OH} = -8\text{mA}$	1.9	2.13		1.9		
		3.0		$I_{OH} = -16\text{mA}$	2.4	2.71		2.4		
		3.0		$I_{OH} = -24\text{mA}$	2.3	2.55		2.3		
$V_{OL}$	LOW Level Output Voltage	1.8	$V_{IN} = V_{IL}$	$I_{OL} = 100\mu\text{A}$		0.01	0.1		0.1	
		2.3				0.01	0.1		0.1	
		3.0				0.00	0.1		0.1	
		2.3		$I_{OL} = 8\text{mA}$		0.10	0.3		0.3	
		3.0		$I_{OL} = 16\text{mA}$		0.18	0.4		0.4	
		3.0		$I_{OL} = 24\text{mA}$		0.28	0.55		0.55	
$I_{IN}$	Input Leakage Current	0-3.6	$V_{IN} = 5.5\text{V}, GND$		-1		1	-1	1	$\mu\text{A}$
$I_{OFF}$	Power Off Leakage Current	0.0	$V_{IN}$ or $V_{OUT} = 5.5\text{V}$		-1		1	-1	1	
$I_{CC}$	Quiescent Supply Current	1.8-3.6	$V_{IN} = 5.5\text{V}, GND$				2.0		20	
$I_{OZ}$	3-State Output Leakage	1.8-3.6	$V_{IN} = V_{IH}$ or $V_{IL}$ $V_O = V_{CC}$ or $GND$				±1		±10	

### AC Electrical Characteristics

Symbol	Parameter	V <sub>CC</sub> (V)	Conditions	T <sub>A</sub> = +25°C			T <sub>A</sub> = -40°C to +85°C		Units	Fig. No.
				Min.	Typ.	Max.	Min.	Max.		
t <sub>PLH</sub> , t <sub>PHL</sub>	Propagation Delay	1.8 2.5 ±0.2 3.3 ±0.3	C <sub>L</sub> = 15pF, R <sub>D</sub> = 1MΩ, S <sub>1</sub> = Open	2.0 0.8 0.5	2.8 1.8 1.3	3.7 2.5 1.7	2.0 0.8 0.5	4.1 2.8 1.9	ns	1 3
t <sub>PLH</sub> , t <sub>PHL</sub>	Propagation Delay	3.3 ±0.3	C <sub>L</sub> = 50pF, R <sub>D</sub> = 500Ω S <sub>1</sub> = Open	1.5	2.6	3.4	1.5	3.7		1 3
t <sub>PZL</sub> , t <sub>PZH</sub>	Output Enable Time	1.8 2.5 ±0.2 3.3 ±0.3	C <sub>L</sub> = 50pF, R <sub>D</sub> = 500Ω R <sub>U</sub> = 500, S <sub>1</sub> = GND for t <sub>PZH</sub> S <sub>1</sub> = V <sub>IN</sub> for t <sub>PZL</sub> V <sub>IN</sub> = 2 x V <sub>CC</sub>	2 1.5 1.5	5.8 4.1 3.1	7.5 5.4 4.1	2 1.5 1.5	8.3 5.9 4.5		1 3
t <sub>PLZ</sub> , t <sub>PHZ</sub>	Output Disable Time	1.8 2.5 ±0.2 3.3 ±0.3	C <sub>L</sub> = 50pF, R <sub>D</sub> = 500Ω R <sub>U</sub> = 500, S <sub>1</sub> = GND for t <sub>PHZ</sub> S <sub>1</sub> = V <sub>IN</sub> for t <sub>PLZ</sub> V <sub>IN</sub> = 2 x V <sub>CC</sub>	2 1.5 1.0	4.9 3.6 2.8	5.9 4.8 3.4	2 1.5 1.0	6.5 5.3 3.7		1 3
C <sub>IN</sub> , C <sub>OUT</sub>	Input Capacitance Output Capacitance	V <sub>IN</sub> = 0 V <sub>OUT</sub> = 0			4 8				pF	
C <sub>PD</sub>	Power Dissipation Capacitance	3.3	Note 3		17					2

**Notes:**

- C<sub>PD</sub> is defined as the value of the internal equivalent capacitance which is derived from dynamic operating current consumption (I<sub>CCD</sub>) at no output loading and operating at 50% duty cycle (see Figure 2). C<sub>PD</sub> is related to I<sub>CCD</sub> dynamic operating current by the expression: I<sub>CCD</sub> = (C<sub>PD</sub>)(V<sub>CC</sub>)(f<sub>IN</sub>) + (I<sub>CC static</sub>).

### AC Loading and Waveforms

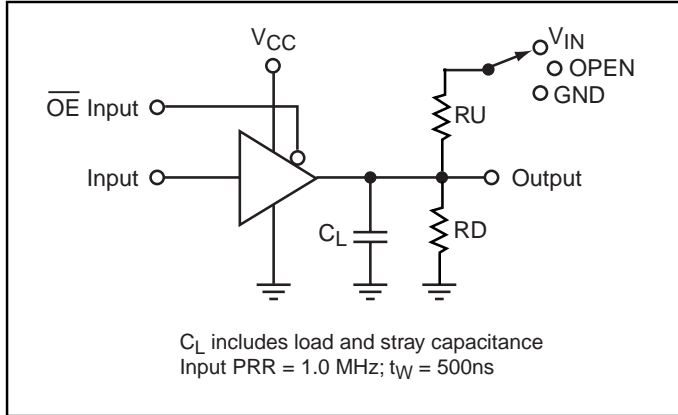

Figure 1. AC Test Circuit

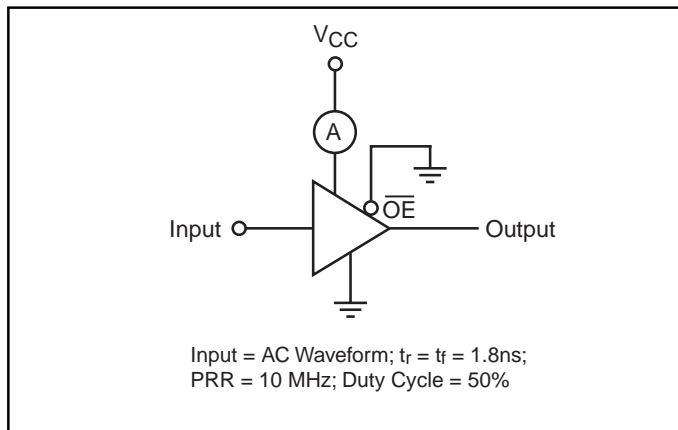

Figure 2. ICCD Test Circuit

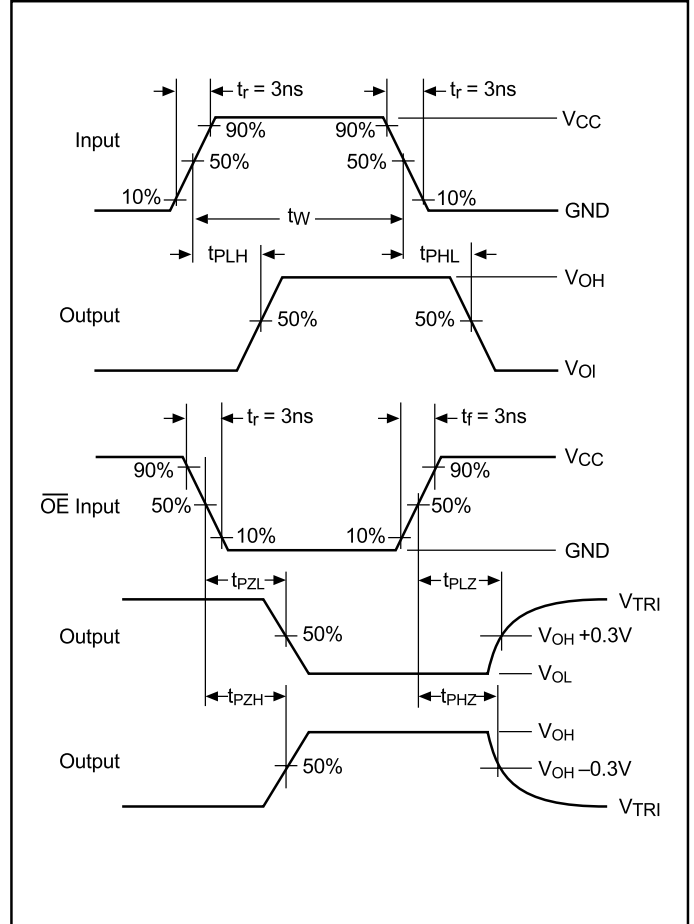
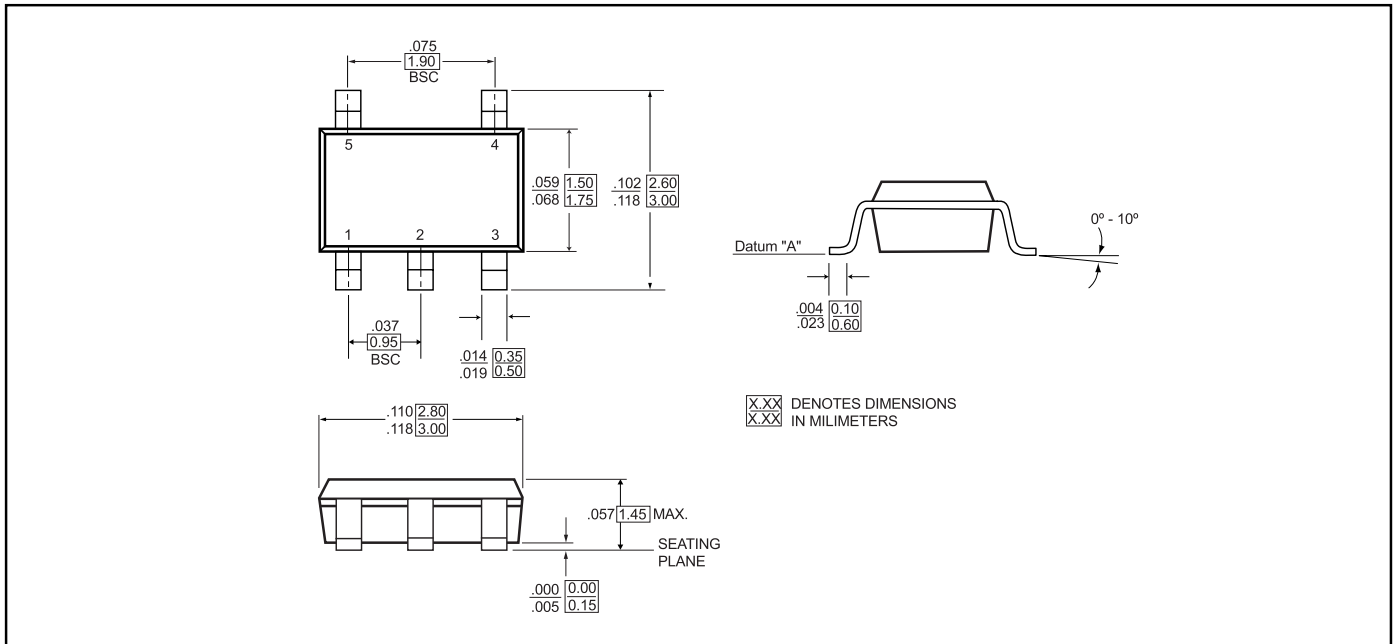
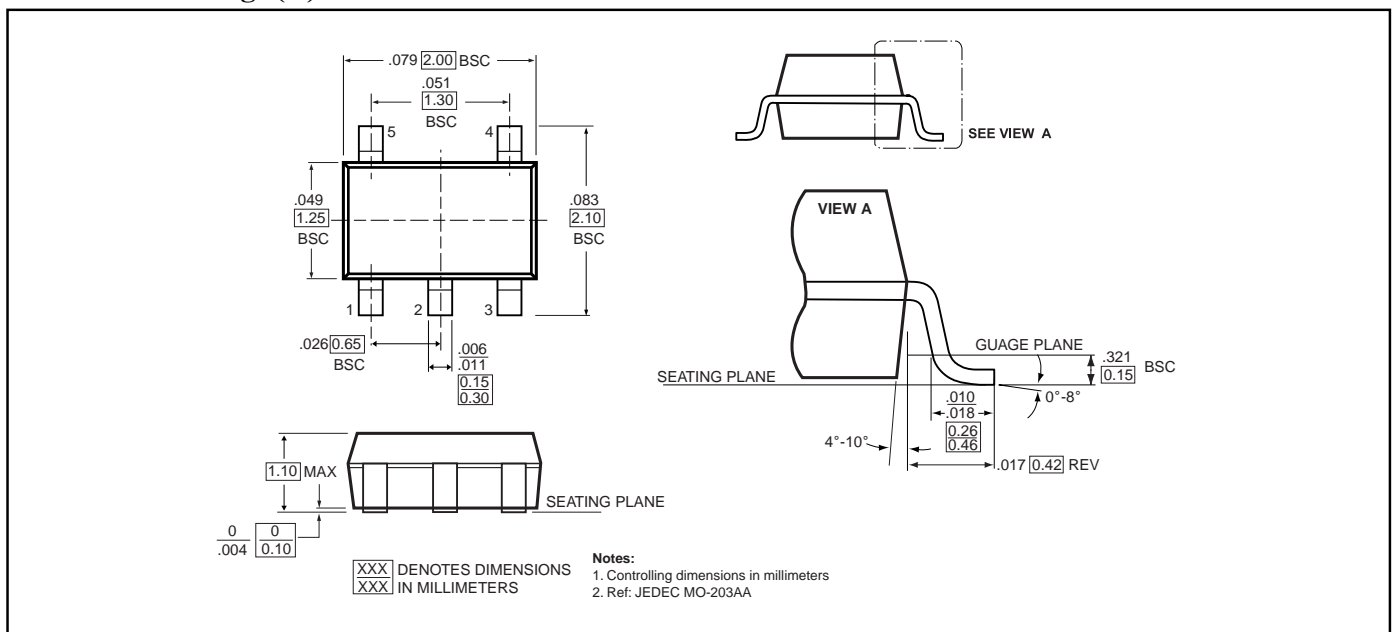

Figure 3. AC Waveforms

### 5-Pin SOT23 Package (T)



### 5-Pin SC70 Package (C)



### Ordering Information

Part	Pin-Package	Top Marking	Operating Range
PI74ST1G125TX	5-Pin - SOT23	L7D	-40°C to 85°C
PI74ST1G125CX	5-Pin - SC70	L7D	-40°C to 85°C

### Pericom Semiconductor Corporation

2380 Bering Drive • San Jose, CA 95131 • 1-800-435-2336 • Fax (408) 435-1100 • <http://www.pericom.com>