



PI74LCX827

Fast CMOS 3.3V
10-Bit Buffers

Product Features

- Functionally compatible with FCT3, LVT, and 74 series 827 families of products
- Tri-State outputs
- 5V Tolerant inputs and outputs
- 2.0V-3.6V V_{CC} supply operation
- Balanced sink and source output drives (24 mA)
- Low ground bounce outputs
- Supports live insertion
- ESD Protection exceeds 2000V, Human Body Model
200V, Machine Model
- Packages available:
 - 24-pin 209-mil wide plastic SSOP (H)
 - 24-pin 173-mil wide plastic TSSOP (L)
 - 24-pin 150-mil wide plastic QSOP (Q)
 - 24-pin 300-mil wide plastic SOIC (S)

Product Description

Pericom Semiconductor's PI74LCX series of logic circuits are produced in the Company's advanced 0.6 micron CMOS technology, achieving industry leading speed grades.

The PI74LCX827 is a 10-bit wide non-inverting bus driver providing high-performance bus interface buffering for wide address/data paths or buses carrying parity. The 10-bit buffers have nanded output enables for maximum control flexibility. They are designed for high-capacitance load drive capability, while providing low-capacitance bus loading at both inputs and outputs.

The PI74LCX827 can be driven from either 3.3V or 5.0V devices allowing this device to be used as a translator in a mixed 3.3/5.0V system.

Logic Block Diagram

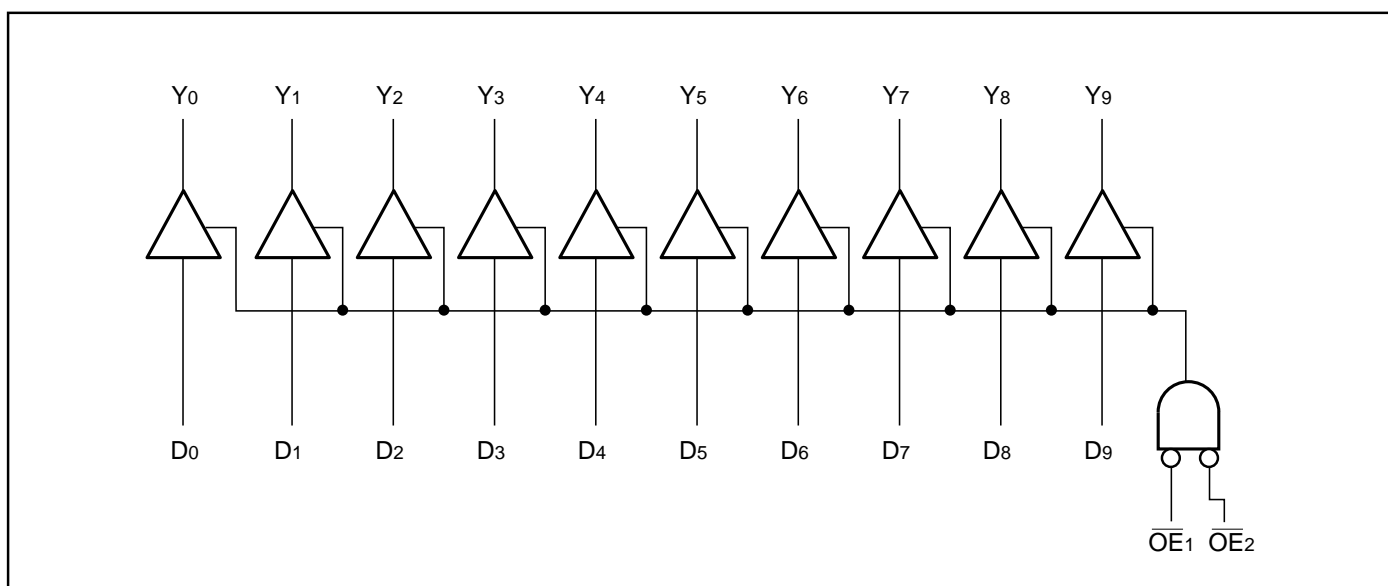

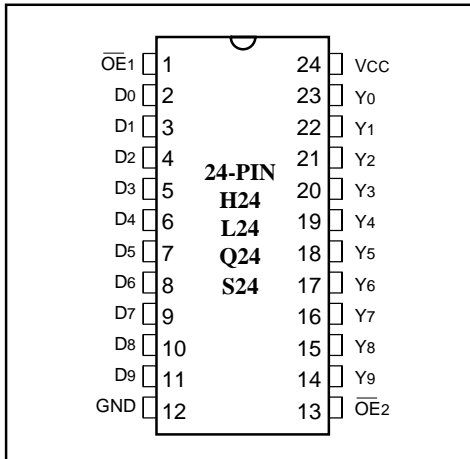
Product Pin Configuration

Product Pin Description

Pin Name	Description
\overline{OE}_N	Output Enable Input (Active LOW)
D0-D9	10-bit Data Inputs
Y0-Y9	10-bit Data Outputs
GND	Ground
VCC	Power

Truth Table⁽¹⁾

Function	Inputs			Outputs
	\overline{OE}_1	\overline{OE}_2	D_N	Y_N
Transparent	L	L	L	L
	L	L	H	H
Three-State	H	X	X	Z
	X	H	X	Z

- H = High Voltage Level
 L = Low Voltage Level
 X = Don't Care
 Z = High Impedance

Maximum Ratings

(Above which the useful life may be impaired. For user guidelines, not tested.)

Storage Temperature	-65°C to +150°C
Ambient Temperature with Power Applied	-40°C to +85°C
Supply Voltage to Ground Potential (Inputs & Vcc Only)	-0.5V to +7.0V
Supply Voltage to Ground Potential (Outputs & D/O Only) ..	-0.5V to +7.0V
DC Input Voltage	-0.5V to +7.0V
DC Output Current	120 mA
Power Dissipation	1.0W

Note:

Stresses greater than those listed under MAXIMUM RATINGS may cause permanent damage to the device. This is a stress rating only and functional operation of the device at these or any other conditions above those indicated in the operational sections of this specification is not implied. Exposure to absolute maximum rating conditions for extended periods may affect reliability.

Recommended Operating Conditions

Symbol	Parameter	Min.	Max.	Units		
V _{CC}	Supply Voltage	Operating	2.0	3.6	V	
		Data Retention	1.5	3.6		
V _I	Input Voltage	0	5.5			
V _O	Output Voltage	HIGH or LOW State	0	V _{CC}		
		TRI-State	0	5.5		
I _{OH} /I _{OL}	Output Current	V _{CC} = 3.0V-3.6V	—	±24		mA
		V _{CC} = 2.7V	—	±12		
T _A	Free-Air Operating Temperature	-40	+85	°C		
Δt/ΔV	Input Edge Rate	V = 0.8V-2.0V, V _{CC} = 3.0V		0	10	ns/V

DC Electrical Characteristics (Over the Operating Range, $T_A = -40^{\circ}\text{C}$ to $+85^{\circ}\text{C}$, $V_{CC} = 2.7\text{V}$ to 3.6V)

Parameters	Description	Test Conditions ⁽¹⁾		Min.	Typ ⁽²⁾	Max.	Units
V_{IH}	Input HIGH Voltage	Guaranteed Logic HIGH Level		2.0	—	—	V
V_{IL}	Input LOW Voltage	Guaranteed Logic LOW Level		—	—	0.8	
V_{OH}	Output HIGH Voltage	$V_{CC} = 2.7\text{-}3.6$	$I_{OH} = -0.1\text{mA}$	$V_{CC}-0.2$	—	—	
		$V_{CC} = 2.7$	$I_{OH} = -12\text{mA}$	2.2	—	—	
		$V_{CC} = 3.0$	$I_{OH} = -18\text{mA}$	2.4	—	—	
			$I_{OH} = -24\text{mA}$	2.2	—	—	
V_{OL}	Output LOW Voltage	$V_{CC} = 2.7\text{-}3.6$	$I_{OL} = 0.1\text{mA}$	—	—	0.2	
		$V_{CC} = 2.7$	$I_{OL} = 12\text{mA}$	—	—	0.4	
		$V_{CC} = 3.0$	$I_{OL} = 16\text{mA}$	—	—	0.4	
			$I_{OL} = 24\text{mA}$	—	—	0.55	
V_{IK}	Clamp Diode Voltage	$V_{CC} = \text{Min.}, I_{IN} = -18\text{mA}$		—	-0.7	-1.2	
I_I	Input Leakage Current	$0 \leq V_I \leq 5.5\text{V}$	$V_{CC} = 2.7\text{-}3.6$	—	—	± 5	μA
I_{OZ}	Tri-State Output Leakage	$0 \leq V_O \leq 5.5\text{V}$ $V_I = V_{IH}$ or V_{IL}	$V_{CC} = 2.7\text{-}3.6$	—	—	± 5	
I_{OFF}	Power Down Disable	$V_{CC} = 0\text{V}, V_{IN}$ or $V_{OUT} \leq 5.5\text{V}$		—	—	10	
I_{CC}	Quiescent Power Supply Current	$V_{CC} = \text{Max.}$	$V_{IN} = \text{GND}$ or V_{CC}	—	0.1	10	
ΔI_{CC}	Quiescent Power Supply Current TTL Inputs HIGH	$V_{CC} = \text{Max.}$	$V_{IN} = V_{CC} - 0.6\text{V}^{(3)}$	—	—	500	

Notes:

1. For Max. or Min. conditions, use appropriate value specified under Electrical Characteristics for the applicable device type.
2. Typical values are at $V_{CC} = 3.3\text{V}$, $+25^{\circ}\text{C}$ ambient.
3. Per TTL driven input; all other inputs at V_{CC} or GND.

Capacitance

Parameters	Description	Test Conditions	Typ.	Units
C_{IN}	Input Capacitance	$V_{CC} = \text{Open}, V_I = 0\text{V}$ or V_{CC}	7	pF
C_{OUT}	Output Capacitance	$V_{CC} = 3.3\text{V}, V_I = 0\text{V}$ or V_{CC}	8	
C_{PD}	Power Dissipation Capacitance	$V_{CC} = 3.3\text{V}, V_I = 0\text{V}$ or $V_{CC}, F = 10\text{MHz}$	25	

Switching Characteristics over Operating Range

Parameters	Description	Conditions	V _{CC} = 3.3V ± 0.3V		V _{CC} = 2.7V		Units
			Min.	Max.	Min.	Max.	
t _{PLH} t _{PHL}	Propagation Delay D _{XX} to O _{XX}	C _L = 50pF R _L = 500Ω	1.5	5.0	1.5	6.0	ns
t _{PZH} t _{PZL}	Output Enable Time		1.5	8.0	1.5	9.6	
t _{PHZ} t _{PLZ}	Output Disable Time		1.5	6.0	1.5	7.2	
tsk(o)	Output Skew ⁽¹⁾		—	1.0	—	—	

Note:

1. Skew between any two outputs, of the same package, switching in the same direction.

Dynamic Switching Characteristics (T_A = +25°C)

Parameters	Description	Test Conditions ⁽¹⁾	Typ.	Units
V _{OLP}	Dynamic LOW Peak Voltage	V _{CC} = 3.3V, C _L = 50pF V _{IH} = 3.3V, V _{IL} = 0V	0.8	V
V _{OLV}	Dynamic LOW Valley Voltage	V _{CC} = 3.3V, C _L = 50pF V _{IH} = 3.3V, V _{IL} = 0V		

Note:

1. Measured with n-1 outputs switching from High-to-Low or Low-to-High. The remaining output is measured in the LOW state.