



EVERYTHING

IN A

NEW

LIGHT.

Mini-Triggered Spark Gaps and Transformers

PerkinElmer's Mini-Triggered

Spark Gaps are designed for high reliability switching up to 4 kV and 10 kA. Constructed of hermetically sealed ceramic-metal, filled with pressurized gas, they are typically used for activating electro-explosive devices such as exploding bridgewires, electronic safe and arm systems, and detonators.

PerkinElmer's Trigger Transformers are matched to the requirements of the Mini-Triggered Spark Gaps to provide a high voltage pulse with a fast rise time and low current. PerkinElmer Trigger Transformers are designed to be the most durable and reliable transformers available.



Features

- High reliability
- Extremely low jitter
- Environmentally durable
- Small size
- Matching trigger transformers

Miniature Triggered Spark Gaps

The triggered spark gap is a three element, gas-filled, ceramic-to-metal, hermetically sealed, pressurized switch that operates in an arc discharge mode, conducting moderately high peak currents for short durations. Commutation between two main electrodes is initiated by a trigger pulse.

Applications

Precision timing and firing for in-flight functions such as rocket motor ignition, warhead detonation and missile stage separation. Each of these applications involves the activation of electro-explosive devices such as:

- Exploding bridgewire (EBW)
- Exploding foil initiator (EFI)
- Electronic safe and arm (ESA)
- Slapper/detonator

These compact small, rugged gaps were designed for high-reliability applications where size, switch speed, and ability to withstand rugged missile environmental conditions of extreme shock, temperature, and vibration are required. They are designed for switching peak currents up to 10kA at operating voltages from 2.0 to 4.0 kV with reliable triggering voltage of 2kV. Prefires and failure to fire have been fully evaluated in the basic gap designs. Switching speeds of 70ns with trigger pulse energies as low as 500 micro-joules is typical.

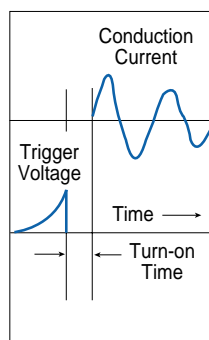

Figure 2. Trigger Voltage Breakdown and Main Gap Conduction Current

Performance Characteristics

Electrical characteristics are determined by testing in the circuit shown in Figure 1. The output circuit consisting of the switch, a 0.2 μF capacitor, and a 0.25 ohm current viewing resistor (CVR) is typical for life testing. It closely matches the conditions found in many typically used circuits. For function testing, the 0.25 ohm CVR is replaced with a 0.005 ohm CVR.

Typical data taken with a 0.005 ohm CVR are shown in Figure 2. This curve contains traces of the trigger voltage and conduction current. First, the trigger voltage rises to the point of trigger breakdown. Then there is a period designated "turn-on" or delay time during which the arc is forming followed by main gap conduction. This delay time varies from 50 to 1500 ns depending on gap operating voltage, trigger mode, amplitude and pulse width.

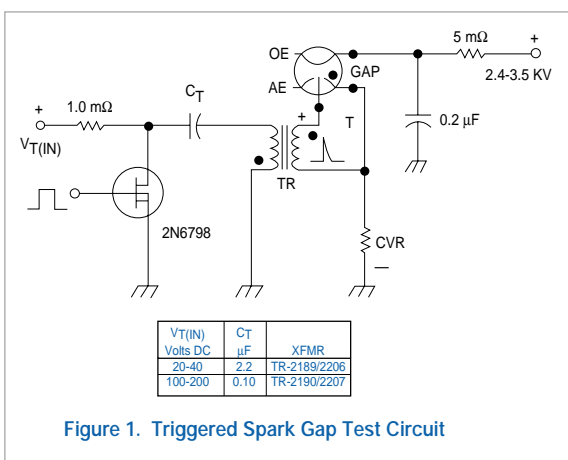

Figure 1. Triggered Spark Gap Test Circuit

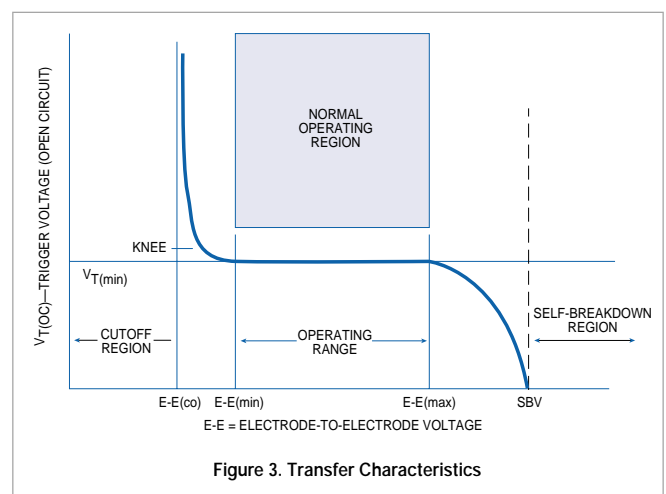

Figure 3. Transfer Characteristics

The trigger transformer circuit must be capable of providing a small sustaining current, typically, a few tens of milliamperes for reliable triggering. the characteristic "ring down" of conduction current is used to compute circuit impedance. The circuit is mechanically designed to yield the lowest possible overall inductance and resistance. Excluding the CVR, a typical circuit resistance is 60 milliohms. Circuit inductance can vary from 30 to 50 nH.

Transfer Characteristics

For the GP-486 the operating range (E-E) is 2.0 to 4.0 kV with a minimum trigger voltage (VT(OC)) open circuit of 2.0 kV. Static Breakdown Voltage (SBV) is 4.5 kV. Trigger mode is "C" - positive trigger and positive opposite electrode (OE). Changing polarities will result in changes in operating characteristics. The triggered spark gap operating range is shown in Figure 3.

Life

End of life is determined by changes in the gap's performance due to electrode erosion or gas cleanup. Prefire (firing without a trigger signal) or failure to fire (no fire with trigger applied) are typical symptoms determining end of life.

Life test data indicate reliable firing on many gaps after 2000 shots at 6000 amps peak current for 200 ns pulse width at 3.5 kV and load of 0.25 ohm. Life will be reduced with higher peak currents.

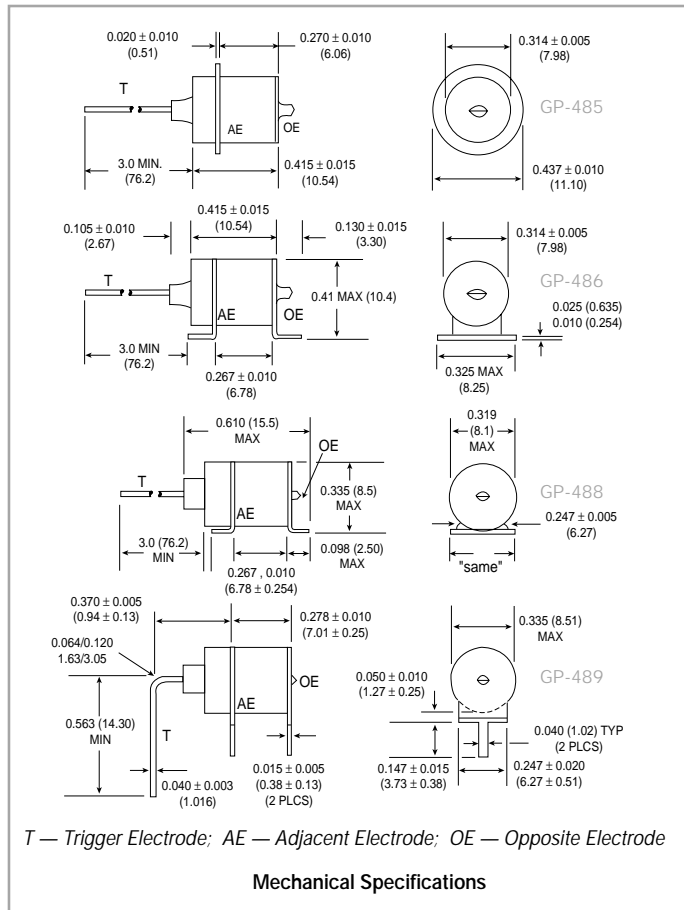

OPERATING SPECIFICATIONS

EG&G Model No.	E - E Operating Range		SBV Minimum Static Breakdown Voltage (kV)	VT(Open Circuit) Minimum Trigger Voltage (kV)	Peak Pulse Current (kA)
	Min (kV)	Max (kV)			
GP-485	2	4	4.5	2	10
GP-486	2	4	4.5	2	10
GP-488	2	4	4.5	2	10
GP-489	2	4	4.5	2	10

Environmental Specifications

Ambient/Operating temperature range	-45 to +100°C. Storage temperature range -65 to + 125°C
Vibration	15 to 500 Hz at 10 g maximum
Shock	per MIL-STD-202D, method 204, Test Condition A (30g, 11 mS).
Thermal Shock	per MIL-STD-202D, method 107, Test Condition B (-65 to + 125°C).
Humidity	per MIL-T-5422E, paragraph 4.4.

Electrical Specifications

Electrode capacity	Less than 5 pf.
Interelectrode resistance	Greater than 10 ¹⁰ ohms at 500 V.

Mechanical Specifications

Envelope	Ceramic-metal, hermetically sealed, exposed metal parts nickel plated.
----------	--



Miniature Trigger Transformers TR-2189/2190/2206/ 2207

These transformers were custom-designed for reliable triggering of the PerkinElmer GP-485/486/488/489 triggered spark gaps. They have operating circuit output voltages well above the maximum required by the switches and are capable of sustaining the trigger to adjacent electrode current during the turn-on phase of gap operation. These transformers are constructed using miniature cores, wound and potted, to produce high output voltage with a minimum of corona at twice rated output voltage. The TR-2189 and TR-2206 are

low input voltage transformers, round, with flying leads and solder connections. The TR-2190 and TR-2207 are high input voltage transformers, square, with pins for PC board connection.

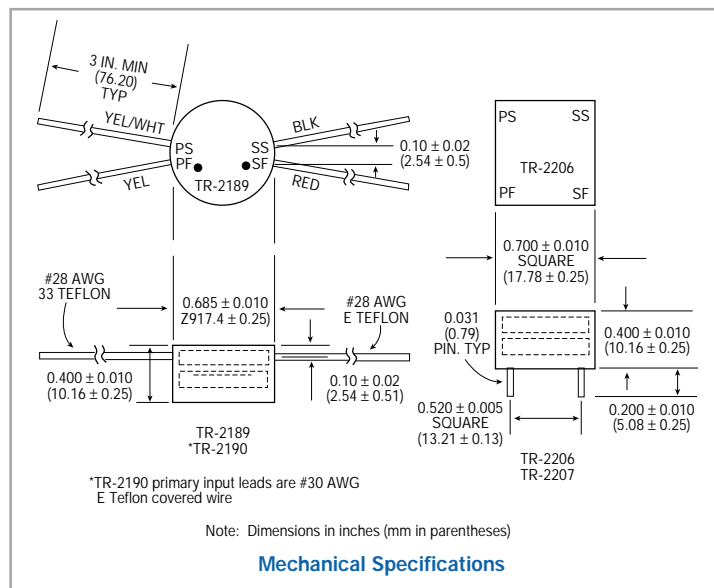
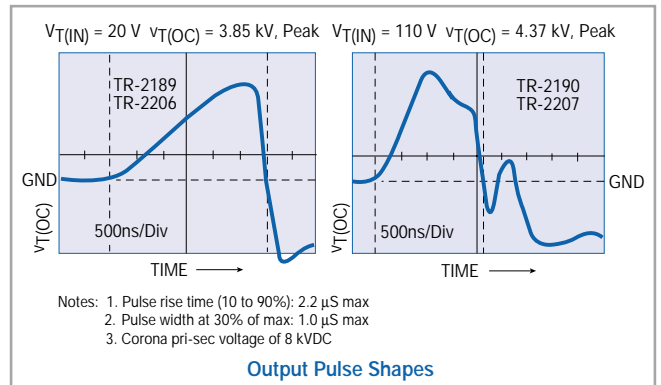
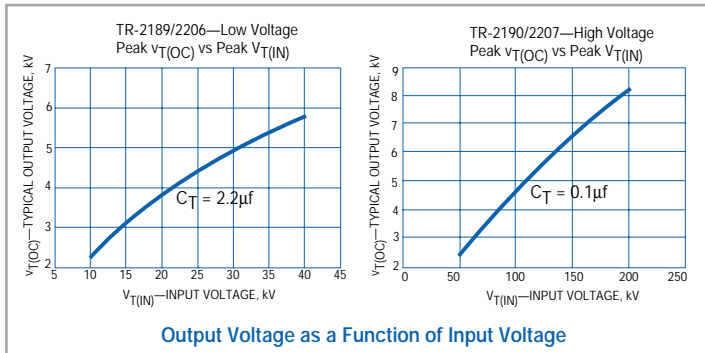
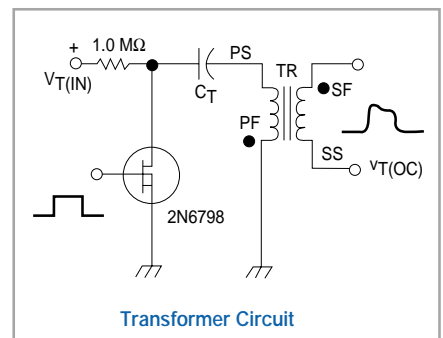

Marking

PerkinElmer's trademark, part designation, and date code.

PerkinElmer welcomes inquiries about special types. We would be pleased to discuss the requirements of your application and the feasibility of designing a type specifically suited to your needs.

Our Quality and Environmental Policy

*“Our goal is to supply our customers
the agreed quantity of specified products and services,
defect free and on time while conducting business
in an environmentally responsible manner”*

* All values are nominal; specifications subject to change without notice.

To request additional information, receive a quote, or place an order, please contact PerkinElmer Optoelectronics at office listed below.



PerkinElmer Optoelectronics
35 Congress Street
Salem, MA 01970
Toll Free: (800) 950-3441 (USA)
Phone: (978) 745-3200
Fax: (978) 745-0894