

.025" NPN Phototransistors

Clear Long T-1 (3 mm) Plastic Package

VTT3323LA, 4LA, 5LA



PACKAGE DIMENSIONS inch (mm)

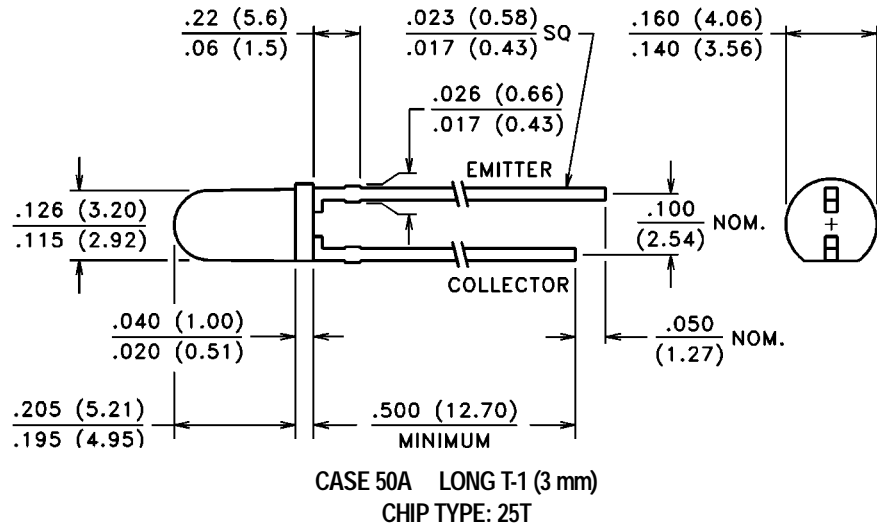

PRODUCT DESCRIPTION

A small area high speed NPN silicon phototransistor mounted in a 3 mm diameter, lensed, end looking, transparent plastic package. These devices are spectrally and mechanically matched to the VTE337xLA series of IREDS.

ABSOLUTE MAXIMUM RATINGS ■

(@ 25°C unless otherwise noted)

Maximum Temperatures	
Storage Temperature:	-40°C to 100°C
Operating Temperature:	-40°C to 100°C
Continuous Power Dissipation:	50 mW
Derate above 30°C:	0.71 mW/°C
Maximum Current:	25 mA
Lead Soldering Temperature:	260°C
	(1.6 mm from case, 5 sec. max.)

ELECTRO-OPTICAL CHARACTERISTICS @ 25°C (See also typical curves, pages 91-92)

Part Number ■	Light Current		Dark Current	Collector Breakdown	Emitter Breakdown	Saturation Voltage	Rise/Fall Time	Angular Response $\theta_{1/2}$		
	I_C		I_{CEO}	$V_{BR(CEO)}$	$V_{BR(ECO)}$	$V_{CE(SAT)}$	t_R/t_F			
	mA	H fc (mW/cm ²) $V_{CE} = 5.0$ V	H = 0	$I_C = 100 \mu A$ H = 0	$I_E = 100 \mu A$ H = 0	$I_C = 1.0$ mA H = 400 fc	$I_C = 1.0$ mA $R_L = 100 \Omega$			
	Min.	Max.	(nA) Max.	V_{CE} (Volts)	Volts, Min.	Volts, Min.	Volts, Max.		μ sec, Typ.	Typ.
VTT3323LA	2.0	—	20 (1)	100	10	30	5.0	0.25	3.0	$\pm 10^\circ$
VTT3324LA	4.0	—	20 (1)	100	10	30	5.0	0.25	4.0	$\pm 10^\circ$
VTT3325LA	6.0	—	20 (1)	100	10	30	5.0	0.25	5.0	$\pm 10^\circ$

■ Refer to General Product Notes, page 2.