

DATA SHEET

PCF21xxC family **LCD drivers**

Product specification
Supersedes data of 1995 May 03
File under Integrated Circuits, IC12

1997 Mar 28

LCD drivers**PCF21xxC family**

CONTENTS

1	FEATURES
2	GENERAL DESCRIPTION
3	QUICK REFERENCE DATA
4	ORDERING INFORMATION
5	BLOCK DIAGRAMS
6	PINNING
6.1	PCF2100C
6.2	PCF2111C
6.3	PCF2112C
7	FUNCTIONAL DESCRIPTION
7.1	PCF2100C
7.2	PCF2111C
7.3	PCF2112C
7.4	Bus control logic
7.5	Timing
7.6	Input circuitry
7.7	Expansion
8	LIMITING VALUES
9	HANDLING
10	DC CHARACTERISTICS
11	AC CHARACTERISTICS
12	PACKAGE OUTLINES
13	SOLDERING
13.1	Plastic dual in-line packages
13.1.1	By dip or wave
13.1.2	Repairing soldered joints
13.2	Plastic small outline packages
13.2.1	By wave
13.2.2	By solder paste reflow
13.2.3	Repairing soldered joints (by hand-held soldering iron or pulse-heated solder tool)
14	DEFINITIONS
15	LIFE SUPPORT APPLICATIONS

LCD drivers

PCF21xxC family

1 FEATURES

- Supply voltage 2.25 to 6.0 V
- Low current consumption
- Serial data input
- CBUS control
- One-point built-in oscillator
- Stand-alone or expanded system
- Power-on reset clear
- LCD segments
 - 40 (PCF2100C)
 - 64 (PCF2111C)
 - 32 (PCF2112C)
- Multiplex rate
 - 1 : 2 (PCF2100C)
 - 1 : 2 (PCF2111C)
 - 1 : 1 (PCF2112C)
- Word length
 - 22 bits (PCF2100C)
 - 34 bits (PCF2111C)
 - 34 bits (PCF2112C).

2 GENERAL DESCRIPTION

The PCF21xxC family are single-chip, silicon gate CMOS LCD driver circuits. A 3-line bus (CBUS) structure enables serial data transfer with microcontrollers. All inputs are CMOS/NMOS compatible.

The devices have the same function and performance as those of the PCF21xx family, which they supersede.

The maximum operating voltage required is reduced from 6.5 to 6.0 V.

3 QUICK REFERENCE DATA

SYMBOL	PARAMETER	CONDITIONS	MIN.	TYP.	MAX.	UNIT
V_{DD}	supply voltage		2.25	–	6.0	V
I_{DD1}	supply current 1	outputs open; CBUS inactive	–	20	50	μ A
I_{DD2}	supply current 2	outputs open; CBUS inactive; $T_{amb} = 25\text{ }^{\circ}\text{C}$	–	20	30	μ A
P_O	power dissipation per output		–	–	100	mW
T_{amb}	operating ambient temperature		–40	–	+85	$^{\circ}\text{C}$
T_{stg}	storage temperature		–65	–	+150	$^{\circ}\text{C}$

4 ORDERING INFORMATION

TYPE NUMBER	PACKAGE		
	NAME	DESCRIPTION	VERSION
PCF2100CP	DIP28	plastic dual in-line package; 28 leads (600 mil)	SOT117-1
PCF2100CT	SO28	plastic small outline package; 28 leads; body width 7.5 mm	SOT136-1
PCF2111CP	DIP40	plastic dual in-line package; 40 leads (600 mil)	SOT129-1
PCF2111CT	VSO40	plastic very small outline package; 40 leads	SOT158-1
PCF2112CP	DIP40	plastic dual in-line package; 40 leads (600 mil)	SOT129-1
PCF2112CT	VSO40	plastic very small outline package; 40 leads	SOT158-1

LCD drivers

PCF21xxC family

5 BLOCK DIAGRAMS

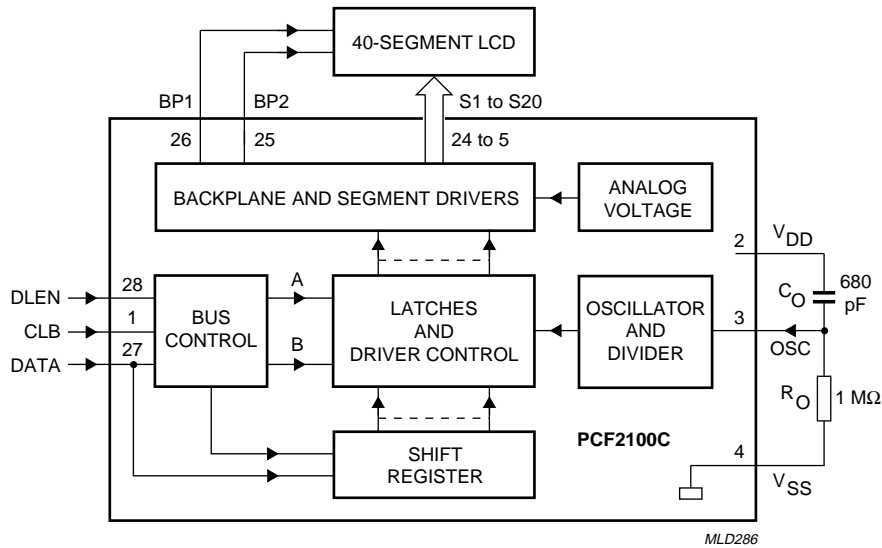

Fig.1 Block diagram; PCF2100C.

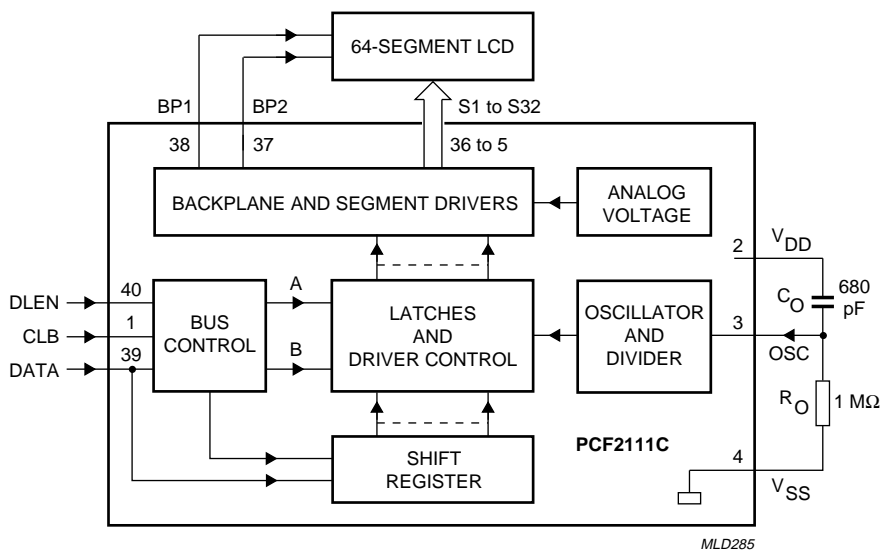

Fig.2 Block diagram; PCF2111C.

LCD drivers

PCF21xxC family

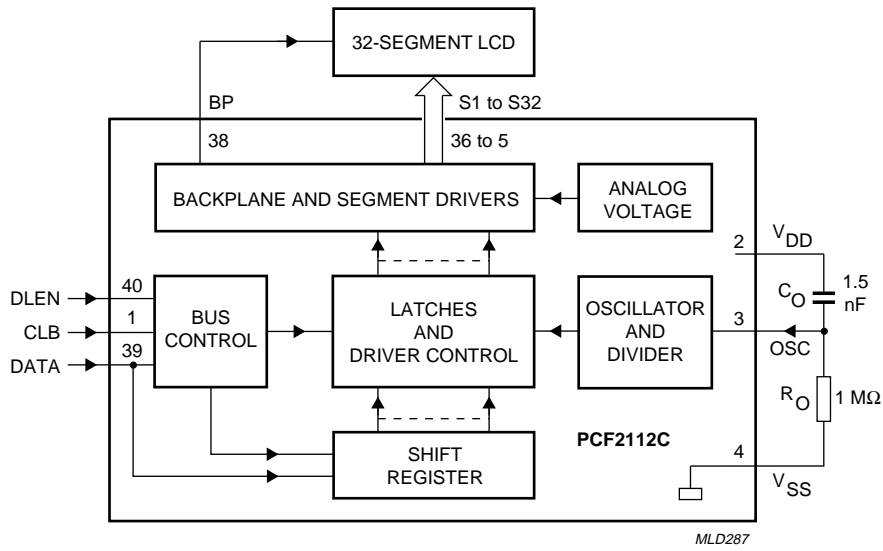

Fig.3 Block diagram; PCF2112C.

LCD drivers

PCF21xxC family

6 PINNING

6.1 PCF2100C

SYMBOL	PIN	DESCRIPTION
CLB	1	clock burst input (CBUS)
V _{DD}	2	supply voltage
OSC	3	oscillator input
V _{SS}	4	supply voltage ground
S20	5	LCD driver output 20
S19	6	LCD driver output 19
S18	7	LCD driver output 18
S17	8	LCD driver output 17
S16	9	LCD driver output 16
S15	10	LCD driver output 15
S14	11	LCD driver output 14
S13	12	LCD driver output 13
S12	13	LCD driver output 12
S11	14	LCD driver output 11
S10	15	LCD driver output 10
S9	16	LCD driver output 9
S8	17	LCD driver output 8
S7	18	LCD driver output 7
S6	19	LCD driver output 6
S5	20	LCD driver output 5
S4	21	LCD driver output 4
S3	22	LCD driver output 3
S2	23	LCD driver output 2
S1	24	LCD driver output 1
BP2	25	backplane driver output 2
BP1	26	backplane driver output 1
DATA	27	data input line (CBUS)
DLEN	28	data input line enable (CBUS)

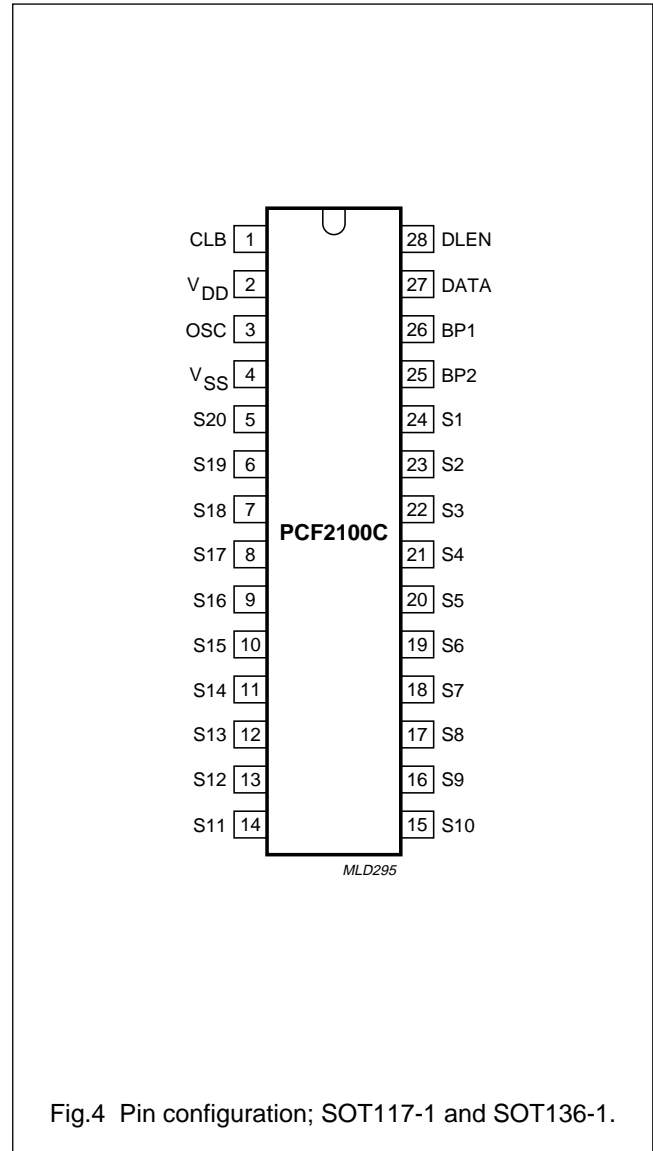

Fig.4 Pin configuration; SOT117-1 and SOT136-1.

LCD drivers

PCF21xxC family

6.2 PCF2111C

SYMBOL	PIN	DESCRIPTION
CLB	1	clock burst input (CBUS)
V _{DD}	2	supply voltage
OSC	3	oscillator input
V _{SS}	4	supply voltage ground
S32	5	LCD driver output 32
S31	6	LCD driver output 31
S30	7	LCD driver output 30
S29	8	LCD driver output 29
S28	9	LCD driver output 28
S27	10	LCD driver output 27
S26	11	LCD driver output 26
S25	12	LCD driver output 25
S24	13	LCD driver output 24
S23	14	LCD driver output 23
S22	15	LCD driver output 22
S21	16	LCD driver output 21
S20	17	LCD driver output 20
S19	18	LCD driver output 19
S18	19	LCD driver output 18
S17	20	LCD driver output 17
S16	21	LCD driver output 16
S15	22	LCD driver output 15
S14	23	LCD driver output 14
S13	24	LCD driver output 13
S12	25	LCD driver output 12
S11	26	LCD driver output 11
S10	27	LCD driver output 10
S9	28	LCD driver output 9
S8	29	LCD driver output 8
S7	30	LCD driver output 7
S6	31	LCD driver output 6
S5	32	LCD driver output 5
S4	33	LCD driver output 4
S3	34	LCD driver output 3
S2	35	LCD driver output 2
S1	36	LCD driver output 1
BP2	37	backplane driver output 2
BP1	38	backplane driver output 1
DATA	39	data input line (CBUS)
DLEN	40	data input line enable (CBUS)

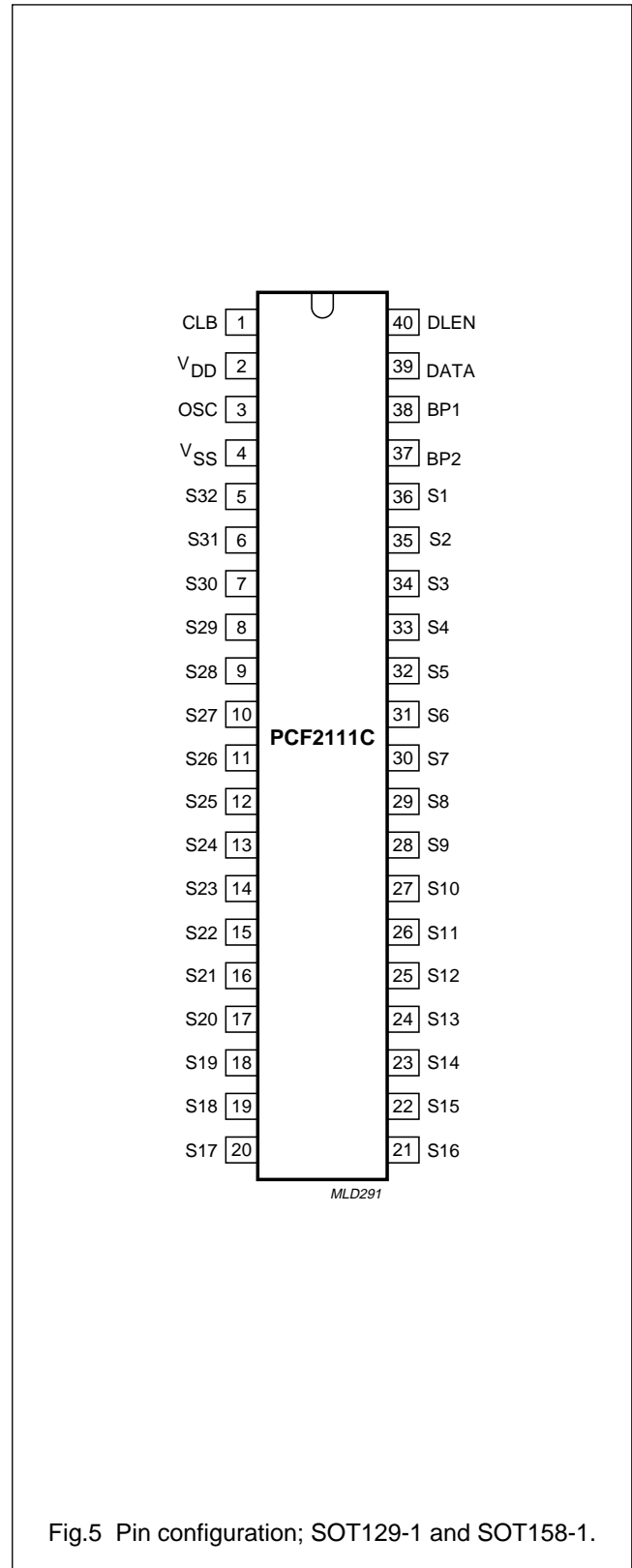

Fig.5 Pin configuration; SOT129-1 and SOT158-1.

LCD drivers

PCF21xxC family

6.3 PCF2112C

SYMBOL	PIN	DESCRIPTION
CLB	1	clock burst input (CBUS)
V _{DD}	2	supply voltage
OSC	3	oscillator input
V _{SS}	4	supply voltage ground
S32	5	LCD driver output 32
S31	6	LCD driver output 31
S30	7	LCD driver output 30
S29	8	LCD driver output 29
S28	9	LCD driver output 28
S27	10	LCD driver output 27
S26	11	LCD driver output 26
S25	12	LCD driver output 25
S24	13	LCD driver output 24
S23	14	LCD driver output 23
S22	15	LCD driver output 22
S21	16	LCD driver output 21
S20	17	LCD driver output 20
S19	18	LCD driver output 19
S18	19	LCD driver output 18
S17	20	LCD driver output 17
S16	21	LCD driver output 16
S15	22	LCD driver output 15
S14	23	LCD driver output 14
S13	24	LCD driver output 13
S12	25	LCD driver output 12
S11	26	LCD driver output 11
S10	27	LCD driver output 10
S9	28	LCD driver output 9
S8	29	LCD driver output 8
S7	30	LCD driver output 7
S6	31	LCD driver output 6
S5	32	LCD driver output 5
S4	33	LCD driver output 4
S3	34	LCD driver output 3
S2	35	LCD driver output 2
S1	36	LCD driver output 1
n.c.	37	not connected
BP	38	backplane driver output
DATA	39	data input line (CBUS)
DLEN	40	data input line enable (CBUS)

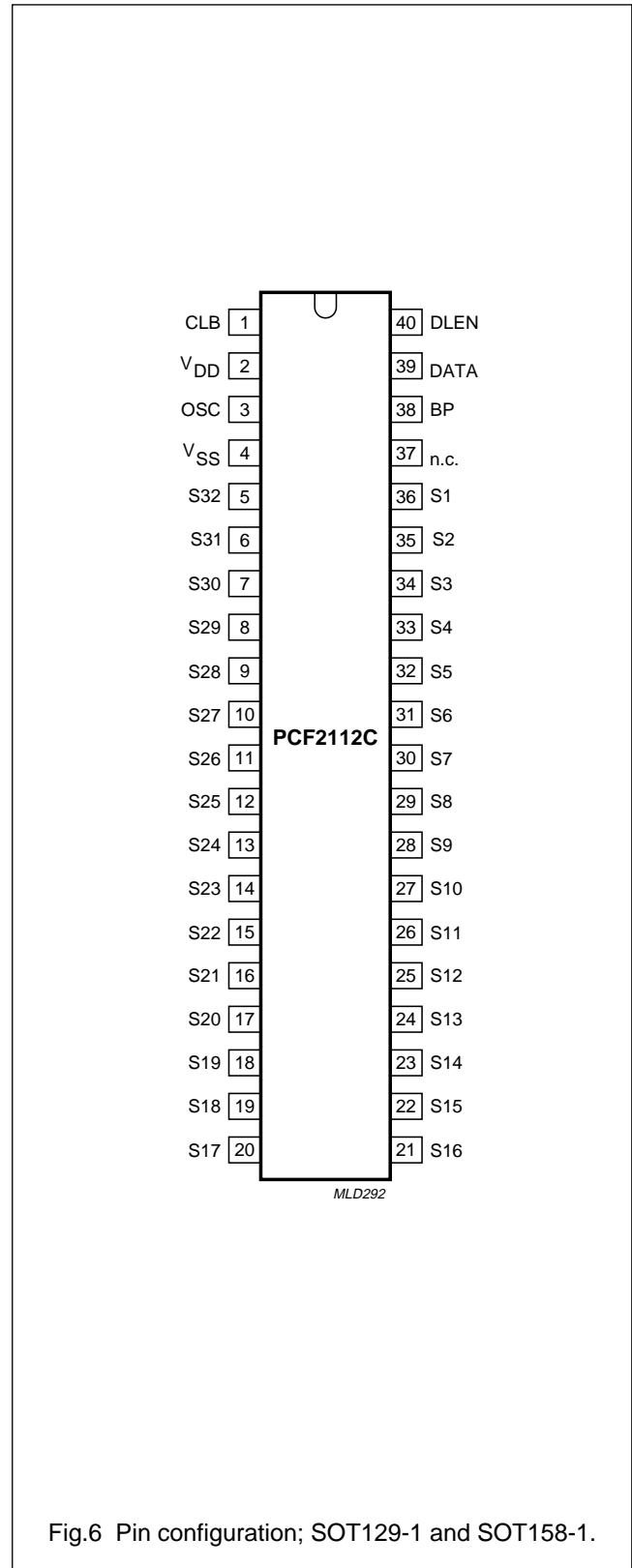

Fig.6 Pin configuration; SOT129-1 and SOT158-1.

LCD drivers

PCF21xxC family

7 FUNCTIONAL DESCRIPTION

An LCD segment or LED output is activated when the corresponding DATA bit is HIGH.

7.1 PCF2100C

When DATA bit 21 is HIGH, the A-latches (BP1) are loaded. With DATA bit 21 LOW, the B-latches (BP2) are loaded. CLB pulse 23 transfers data from the shift register to the selected latches.

7.2 PCF2111C

When DATA bit 33 is HIGH, the A-latches (BP1) are loaded. With DATA bit 33 LOW, the B-latches (BP2) are loaded. CLB pulse 35 transfers data from the shift register to the selected latches.

7.3 PCF2112C

When DATA bit 33 is HIGH, the latches are loaded. CLB pulse 35 transfers data from the shift register to the selected latches.

7.4 Bus control logic

The following tests are carried out by the bus control logic:

1. Test on leading zero
2. Test on number of DATA bits
3. Test of disturbed DLEN and DATA signals during transmission.

If one of the test conditions is not fulfilled, no action follows the load condition (load pulse with DLEN LOW) and the driver is ready to receive new data.

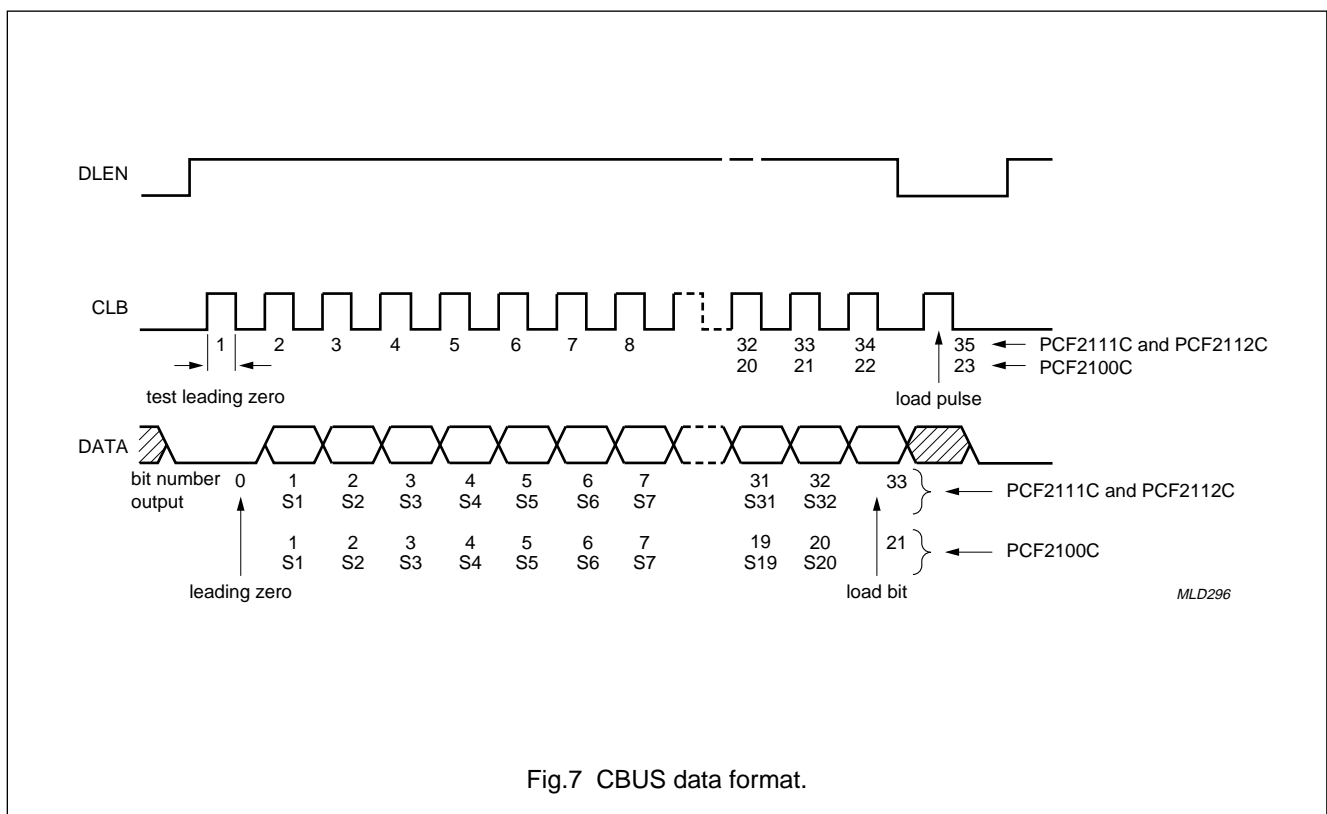

LCD drivers

PCF21xxC family

7.5 Timing

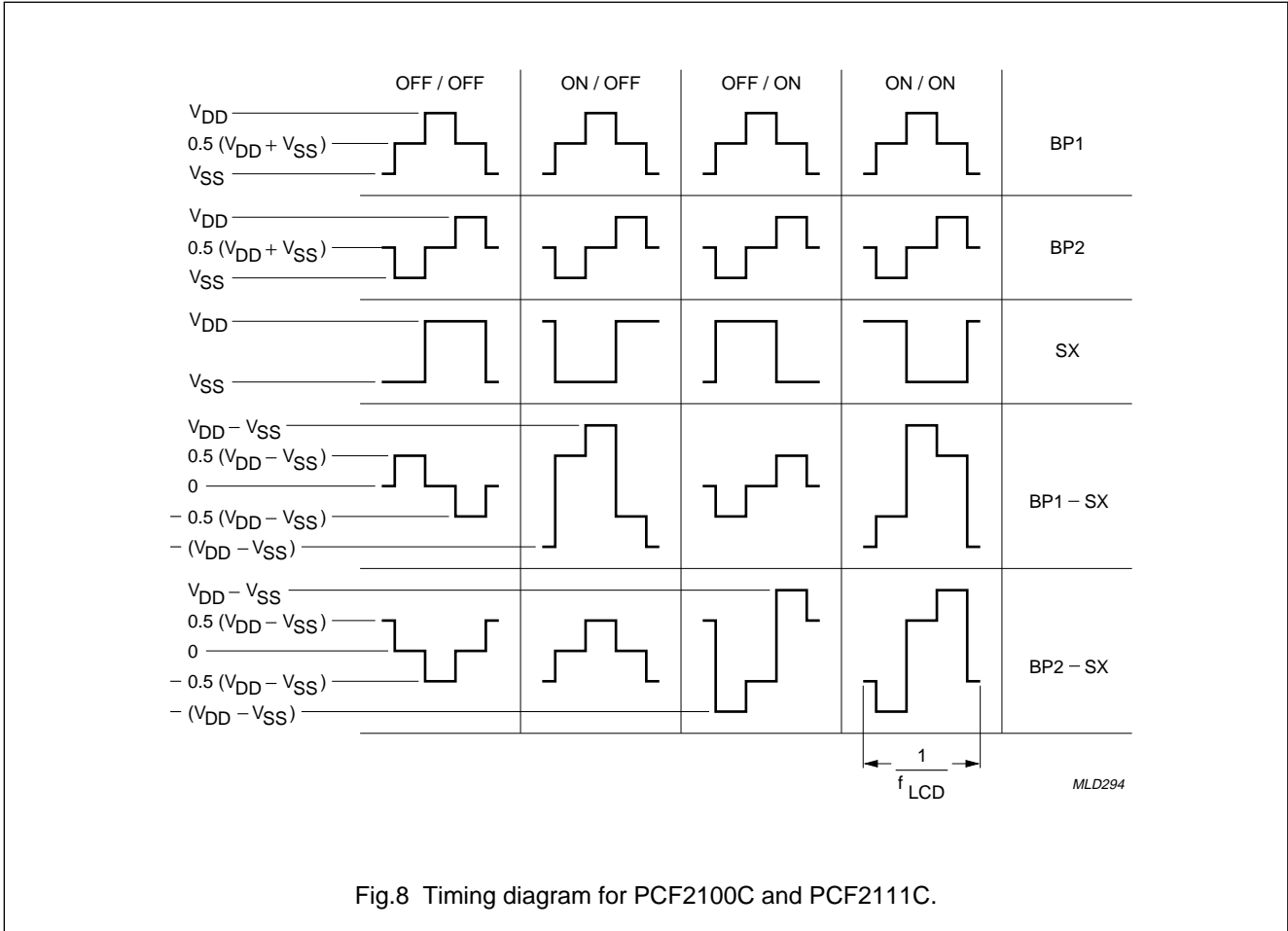

Fig.8 Timing diagram for PCF2100C and PCF2111C.

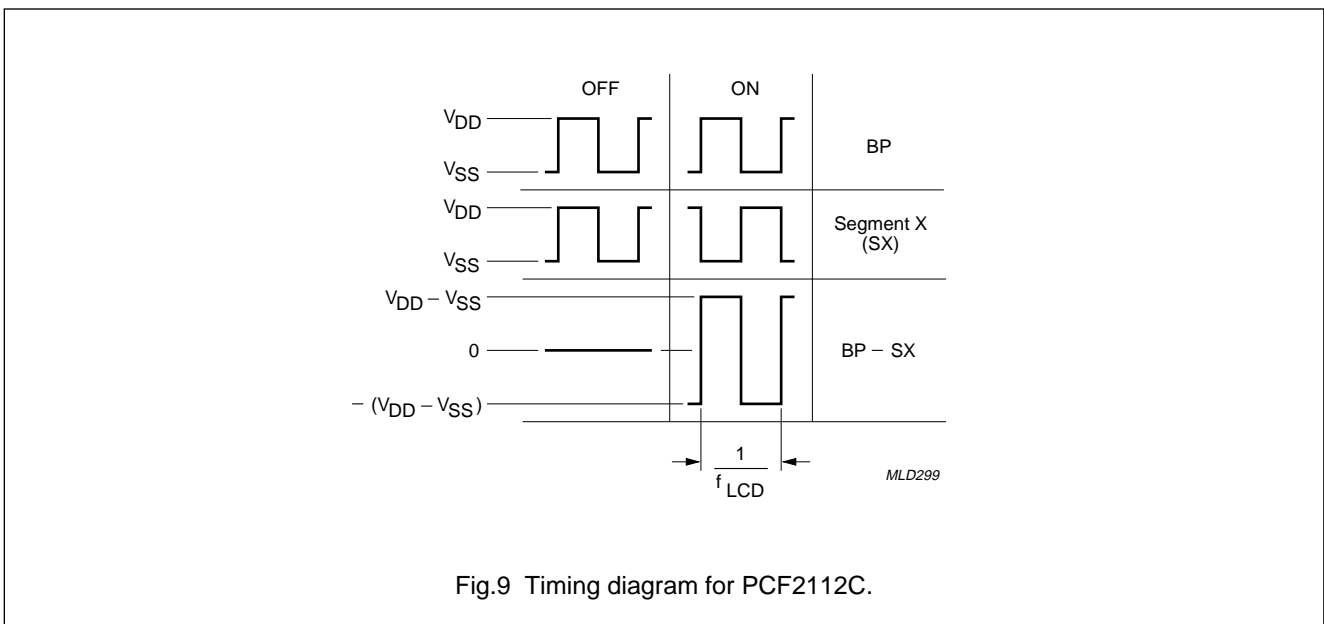
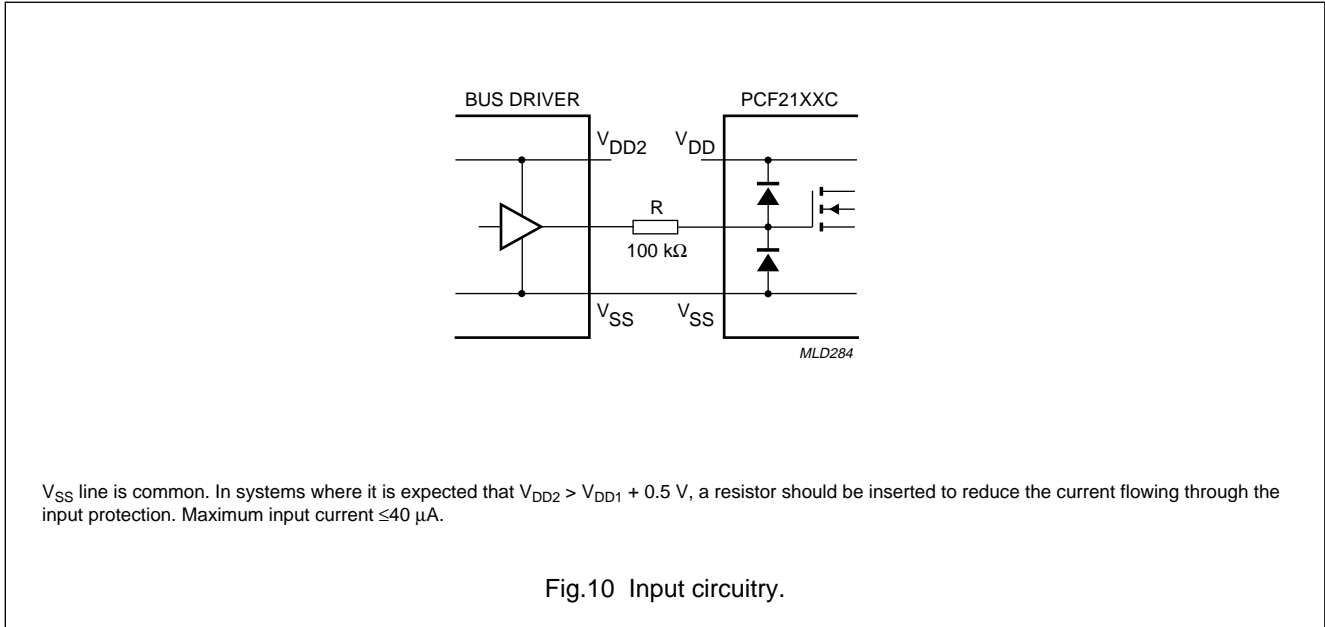

Fig.9 Timing diagram for PCF2112C.

LCD drivers

PCF21xxC family

7.6 Input circuitry



7.7 Expansion

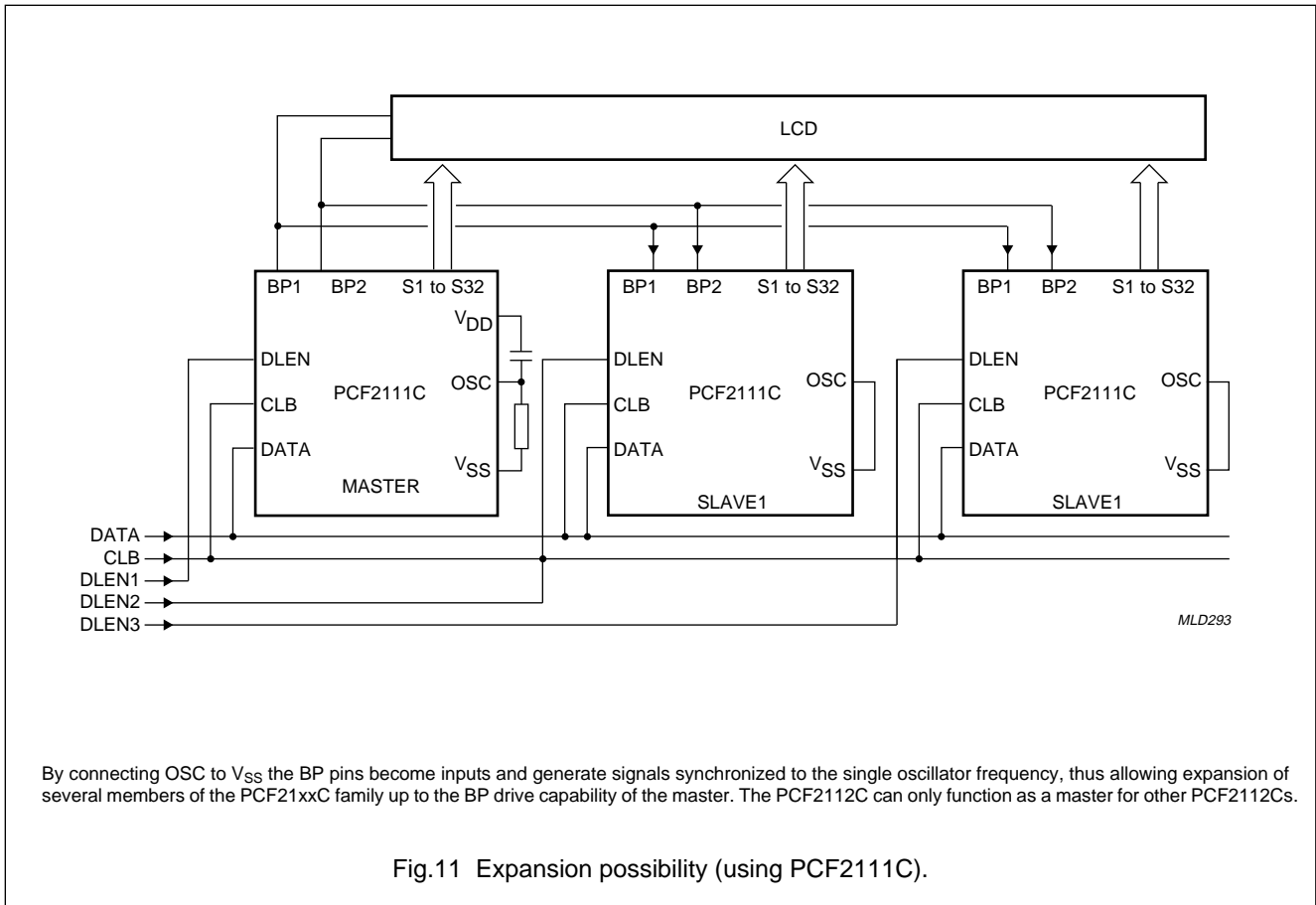

LCD drivers

PCF21xxC family

8 LIMITING VALUES

In accordance with the Absolute Maximum Rating System (IEC 134).

SYMBOL	PARAMETER	CONDITIONS	MIN.	MAX.	UNIT
V_{DD}	supply voltage		-0.5	+8.0	V
V_I	input voltage DLEN, CLB, DATA and OSC		$V_{SS} - 0.5$	$V_{DD} + 0.5$	V
V_O	output voltage BP1, BP2 and S1 to S32		$V_{SS} - 0.5$	$V_{DD} + 0.5$	V
I_{DD}, I_{SS}	supply current		-50	+50	mA
I_I	DC input current		-20	+20	mA
I_O	DC output current		-25	+25	mA
P_{tot}	total power dissipation per package	note 1	-	500	mW
P_O	power dissipation per output		-	100	mW
T_{stg}	storage temperature		-65	+150	°C

Note

- Derate by 7.7 mW/K when $T_{amb} > 60$ °C.

9 HANDLING

Inputs and outputs are protected against electrostatic discharge in normal handling. However, to be totally safe, it is desirable to take normal precautions appropriate to handling MOS devices. See *"Handling MOS devices"*.

ESD in accordance with *"MIL STD 883C, Method 3015"*.

LCD drivers

PCF21xxC family

10 DC CHARACTERISTICS

$V_{DD} = 2.25$ to 6.0 V; $V_{SS} = 0$ V; $T_{amb} = -40$ to $+80$ °C; $R_O = 1$ M Ω ; $C_O = 680$ pF; unless otherwise specified.

SYMBOL	PARAMETER	CONDITIONS	MIN.	TYP.	MAX.	UNIT
Supply						
V_{DD}	supply voltage		2.25	–	6.0	V
I_{DD}	supply current	note 1; see Fig.13	–	20	50	μ A
		note 1; $T_{amb} = 25$ °C; see Fig.13	–	20	30	μ A
V_{POR}	power-on reset voltage level	note 2	–	1.0	1.6	V
Inputs CLB, DATA and DLEN						
V_{IL}	LOW level input voltage		–	–	0.8	V
V_{IH}	HIGH level input voltage		2.0	–	–	V
I_{LI}	input leakage current	$V_I = V_{SS}$ or V_{DD}	–	–	± 1	μ A
C_i	input capacitance	note 3	–	–	10	pF
Input OSC						
I_{osc}	oscillator start-up current	$V_I = V_{SS}$	0.5	1.2	5.0	μ A
LCD outputs						
V_{BP}	DC voltage of backplane drivers		–	± 20	–	mV
$Z_{O(BP)}$	backplane driver output impedance	note 4; $V_{DD} = 5$ V	–	0.5	5.0	k Ω
$Z_{O(S)}$	segment driver output impedance	note 4; $V_{DD} = 5$ V	–	1	7	k Ω

Notes

1. Outputs open; CBUS inactive.
2. Resets all logic, when $V_{DD} < V_{POR}$.
3. Periodically sampled (not 100% tested).
4. Outputs measured one at a time.

LCD drivers

PCF21xxC family

11 AC CHARACTERISTICS

$V_{DD} = 2.25$ to 6.0 V; $V_{SS} = 0$ V; $T_{amb} = -40$ to $+80$ °C; $R_O = 1$ M Ω ; $C_O = 680$ pF; all timing values are referenced to V_{IH} and V_{IL} levels with an input voltage swing of V_{SS} to V_{DD} ; unless otherwise specified.

SYMBOL	PARAMETER	CONDITIONS	MIN.	TYP.	MAX.	UNIT
Inputs CLB, DATA and DLEN (see Fig.12)						
t_{SUDA}	data set-up time		3	–	–	μ s
t_{HDDA}	data hold time		3	–	–	μ s
t_{SUEN}	enable set-up time		1	–	–	μ s
t_{SUDI}	disable set-up time		2	–	–	μ s
t_{SULD}	load pulse set-up time		2.5	–	–	μ s
t_{BUSY}	busy time		3	–	–	μ s
t_{WH}	CLB HIGH time		1	–	–	μ s
t_{WL}	CLB LOW time		5	–	–	μ s
t_{CLB}	CLB cycle time		10	–	–	μ s
t_r	rise time		–	–	10	μ s
t_f	fall time		–	–	10	μ s
LCD timing (see Figs. 12, 14, 15, 16 and 17)						
f_{LCD}	LCD frame frequency PCF2100C, PCF2111C PCF2112C	$C_O = 1.5$ nF	60 30	75 35	100 50	Hz Hz
t_{BS}	transfer time with test loads	$V_{DD} = 5$ V	–	20	100	μ s
t_{PLCD}	driver delay time with test loads	$V_{DD} = 5$ V	–	20	100	μ s

LCD drivers

PCF21xxC family

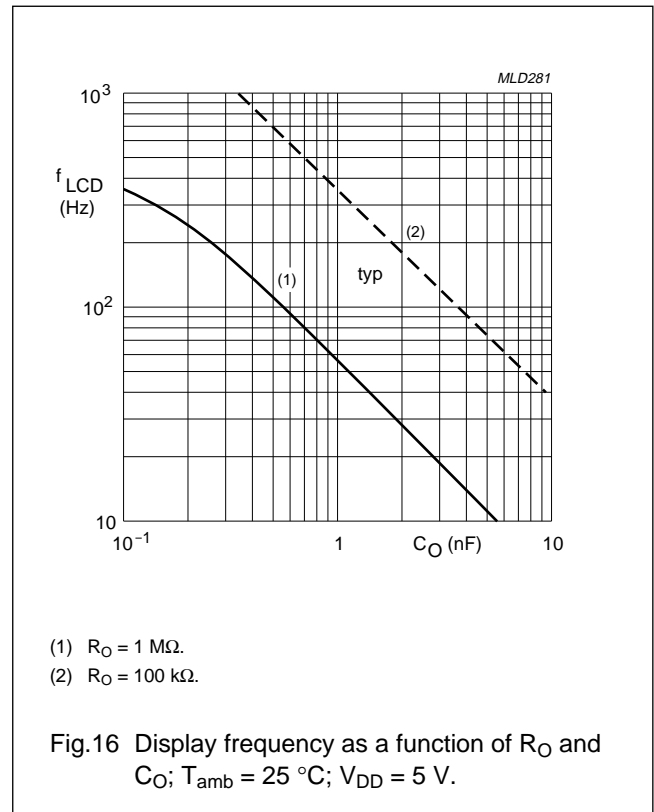
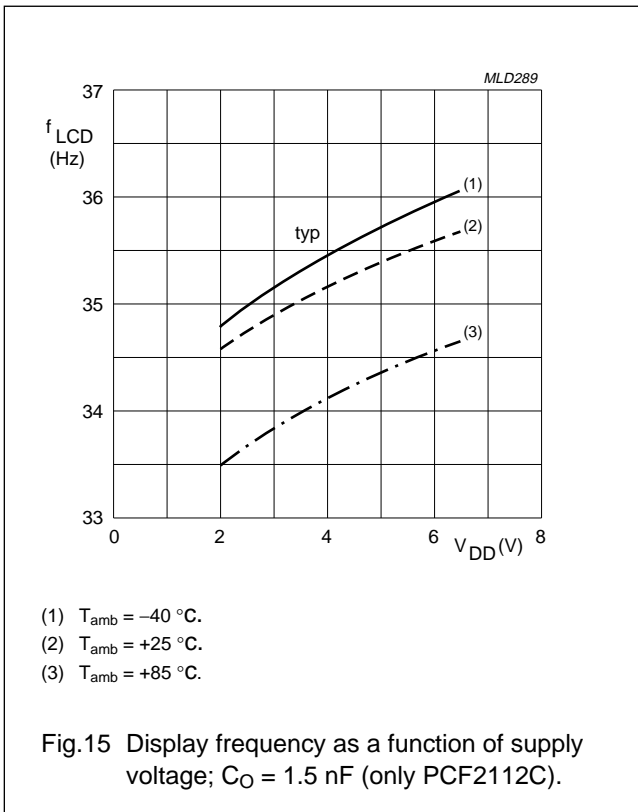
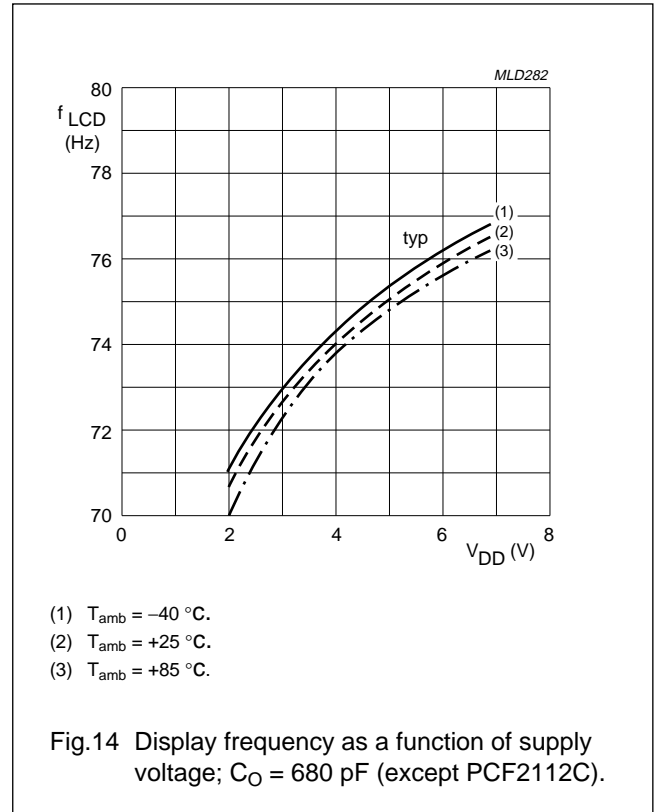
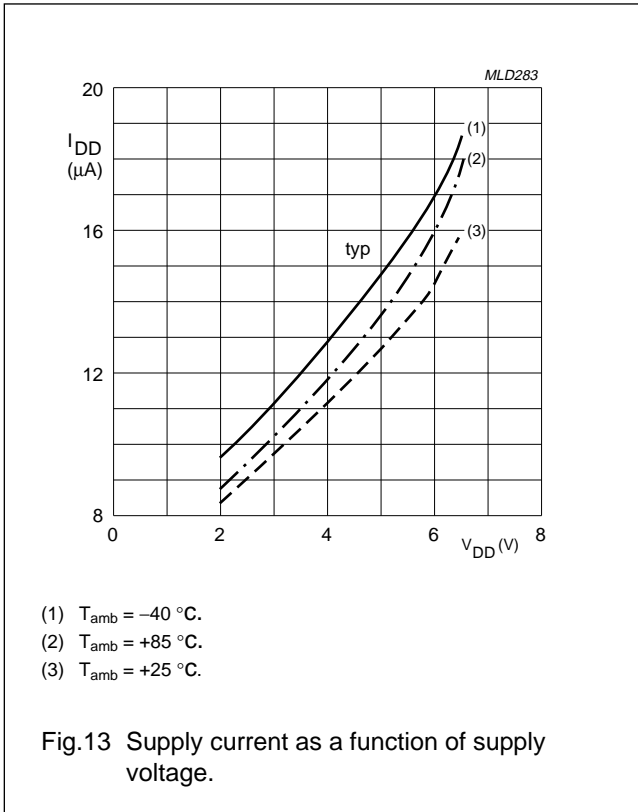

LCD drivers

PCF21xxC family

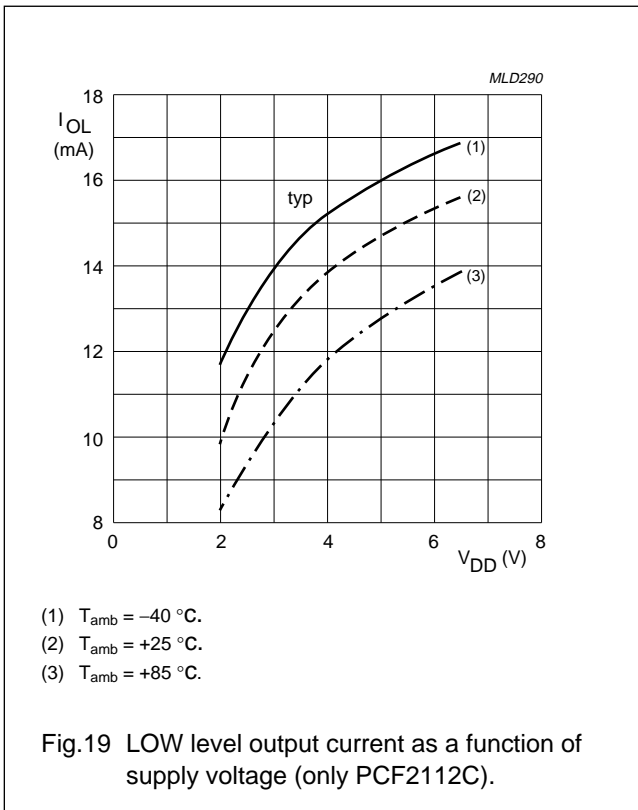
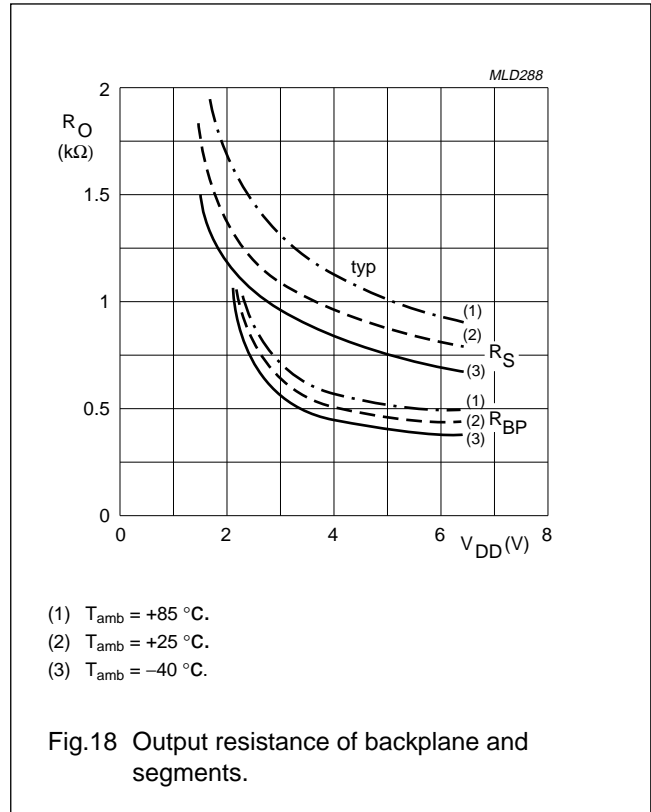
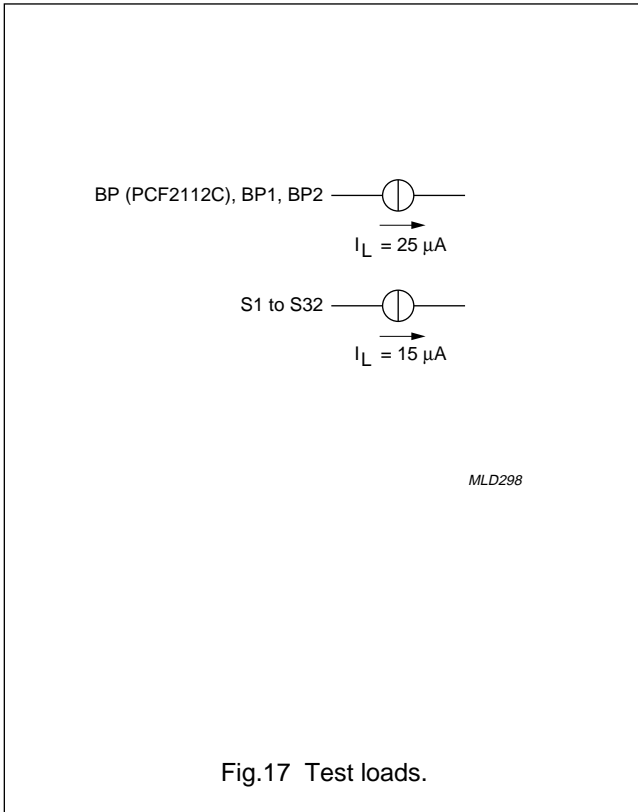

LCD drivers

PCF21xxC family

12 PACKAGE OUTLINES

DIP28: plastic dual in-line package; 28 leads (600 mil)

SOT117-1

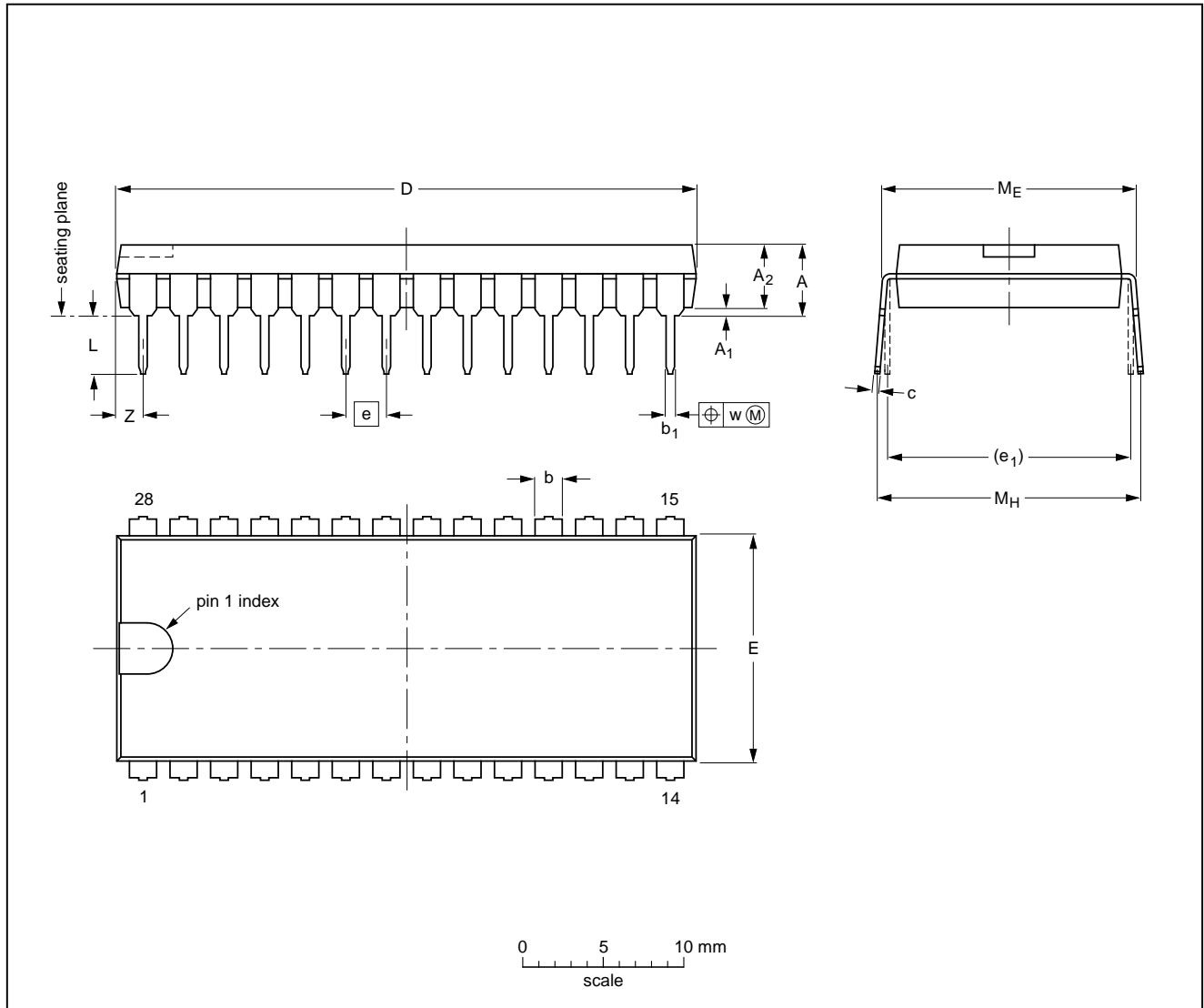

DIMENSIONS (inch dimensions are derived from the original mm dimensions)

UNIT	A max.	A ₁ min.	A ₂ max.	b	b ₁	c	D ⁽¹⁾	E ⁽¹⁾	e	e ₁	L	M _E	M _H	w	Z ⁽¹⁾ max.
mm	5.1	0.51	4.0	1.7 1.3	0.53 0.38	0.32 0.23	36.0 35.0	14.1 13.7	2.54	15.24	3.9 3.4	15.80 15.24	17.15 15.90	0.25	1.7
inches	0.20	0.020	0.16	0.066 0.051	0.020 0.014	0.013 0.009	1.41 1.34	0.56 0.54	0.10	0.60	0.15 0.13	0.62 0.60	0.68 0.63	0.01	0.067

Note

1. Plastic or metal protrusions of 0.25 mm maximum per side are not included.

OUTLINE VERSION	REFERENCES				EUROPEAN PROJECTION	ISSUE DATE
	IEC	JEDEC	EIAJ			
SOT117-1	051G05	MO-015AH				92-11-17 95-01-14

LCD drivers

PCF21xxC family

DIP40: plastic dual in-line package; 40 leads (600 mil)

SOT129-1

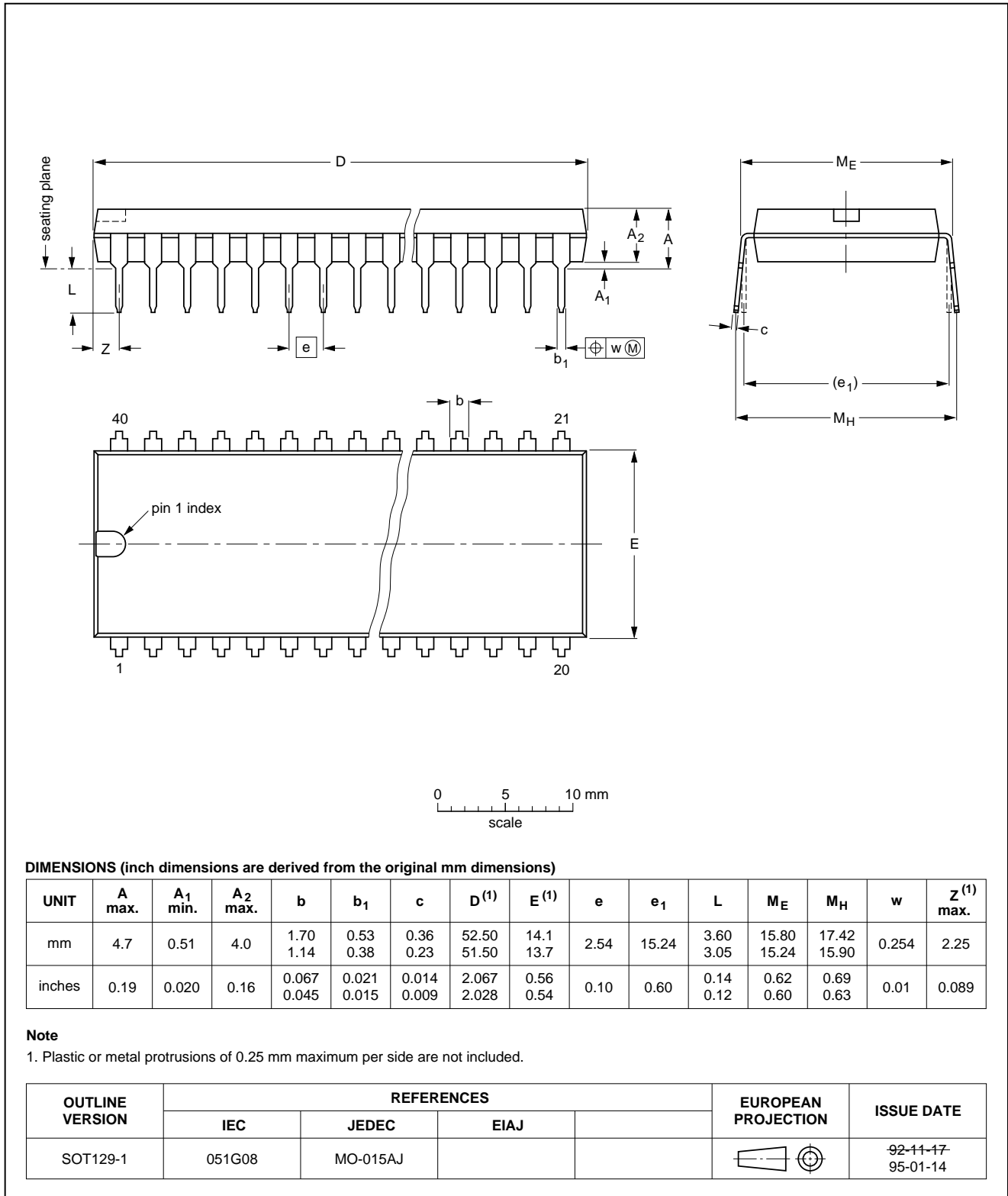

LCD drivers

PCF21xxC family

SO28: plastic small outline package; 28 leads; body width 7.5 mm

SOT136-1

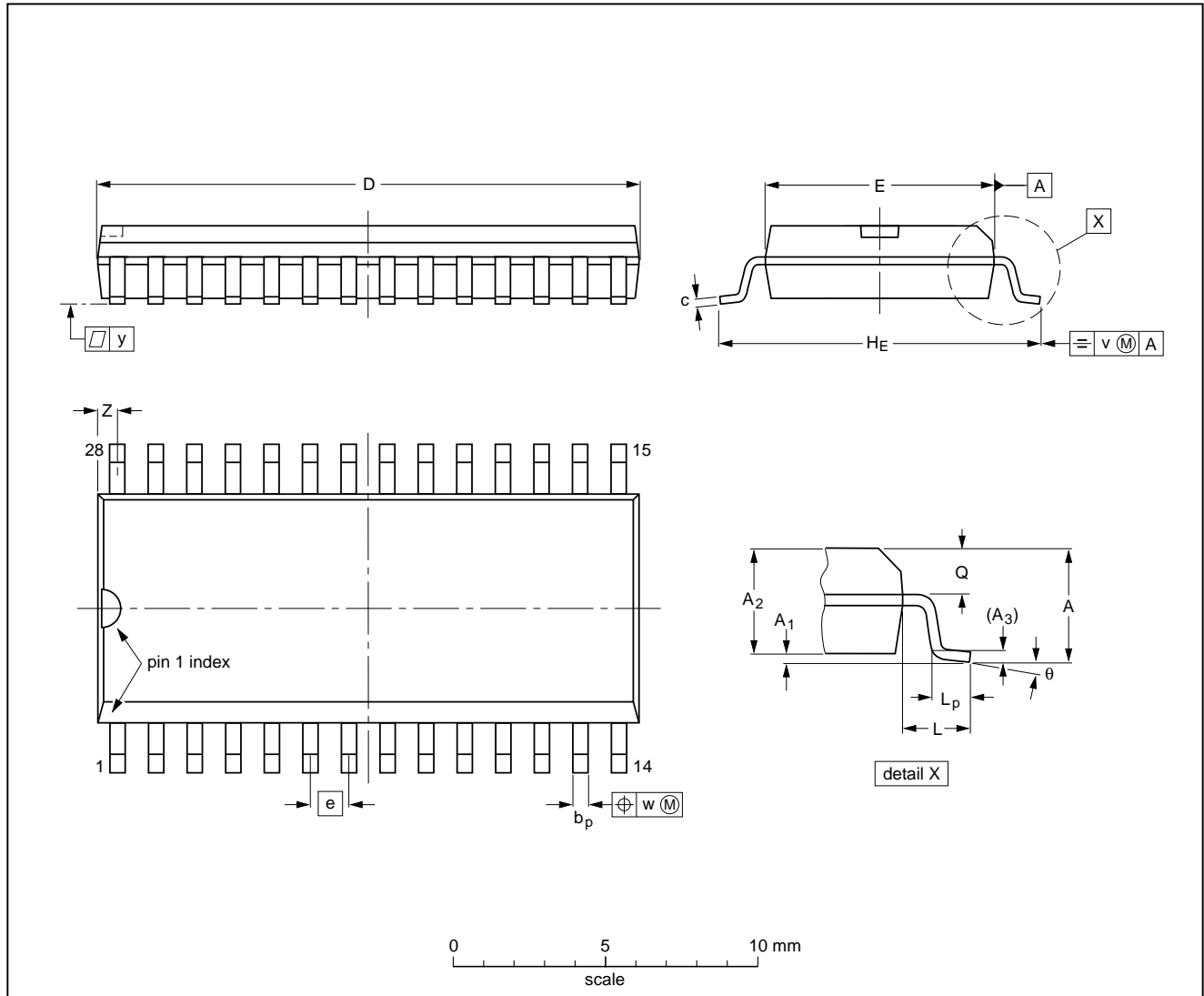

DIMENSIONS (inch dimensions are derived from the original mm dimensions)

UNIT	A max.	A ₁	A ₂	A ₃	b _p	c	D ⁽¹⁾	E ⁽¹⁾	e	H _E	L	L _p	Q	v	w	y	Z ⁽¹⁾	θ
mm	2.65	0.30 0.10	2.45 2.25	0.25	0.49 0.36	0.32 0.23	18.1 17.7	7.6 7.4	1.27	10.65 10.00	1.4	1.1 0.4	1.1 1.0	0.25	0.25	0.1	0.9 0.4	8° 0°
inches	0.10	0.012 0.004	0.096 0.089	0.01	0.019 0.014	0.013 0.009	0.71 0.69	0.30 0.29	0.050	0.42 0.39	0.055	0.043 0.016	0.043 0.039	0.01	0.01	0.004	0.035 0.016	

Note

1. Plastic or metal protrusions of 0.15 mm maximum per side are not included.

OUTLINE VERSION	REFERENCES				EUROPEAN PROJECTION	ISSUE DATE
	IEC	JEDEC	EIAJ			
SOT136-1	075E06	MS-013AE				91-08-13 95-01-24

LCD drivers

PCF21xxC family

VSO40: plastic very small outline package; 40 leads

SOT158-1

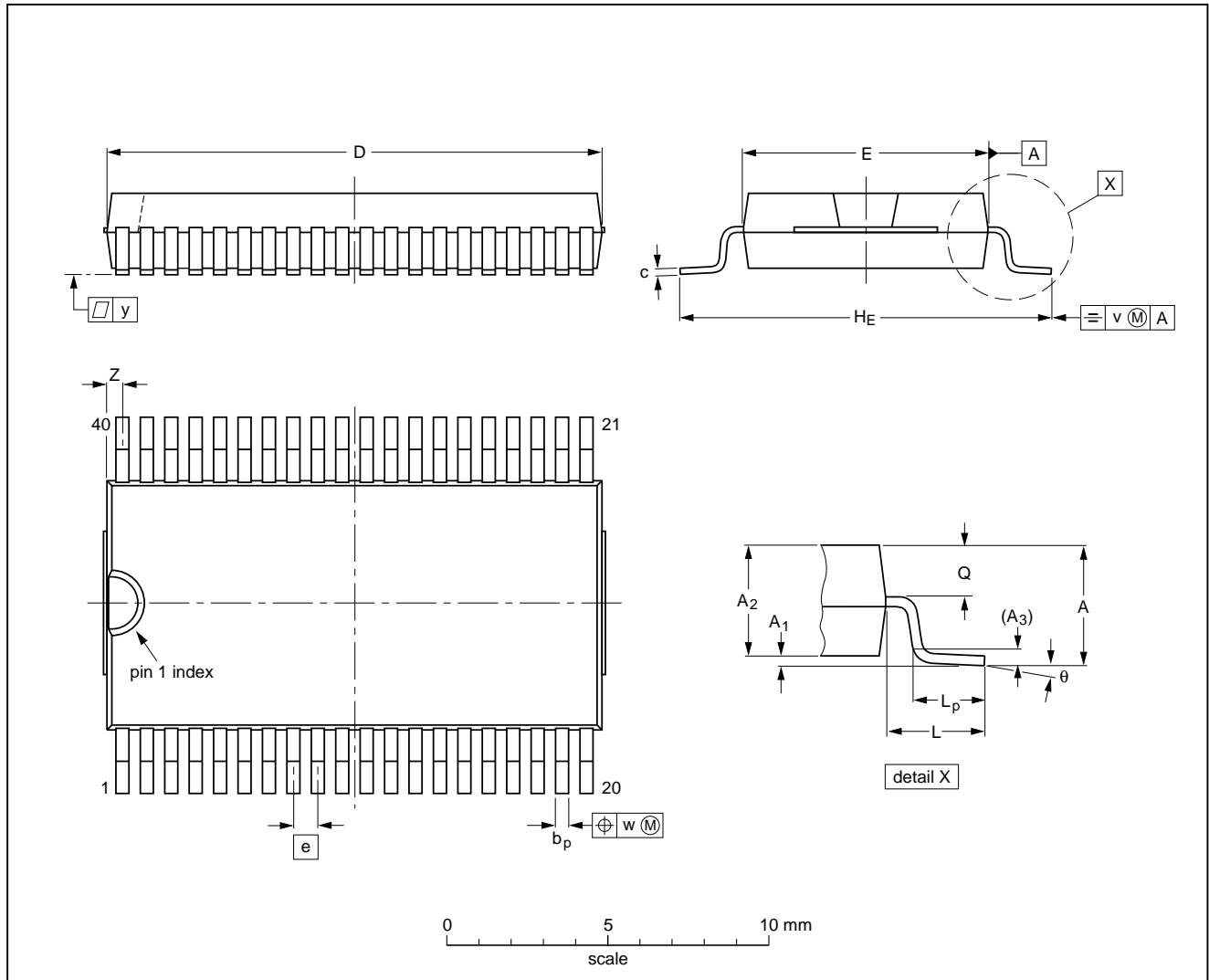

DIMENSIONS (inch dimensions are derived from the original mm dimensions)

UNIT	A max.	A ₁	A ₂	A ₃	b _p	c	D ⁽¹⁾	E ⁽²⁾	e	H _E	L	L _p	Q	v	w	y	Z ⁽¹⁾	θ
mm	2.70	0.3 0.1	2.45 2.25	0.25	0.42 0.30	0.22 0.14	15.6 15.2	7.6 7.5	0.762	12.3 11.8	2.25	1.7 1.5	1.15 1.05	0.2	0.1	0.1	0.6 0.3	7° 0°
inches	0.11	0.012 0.004	0.096 0.089	0.010	0.017 0.012	0.0087 0.0055	0.61 0.60	0.30 0.29	0.03	0.48 0.46	0.089	0.067 0.059	0.045 0.041	0.008	0.004	0.004	0.024 0.012	

Notes

1. Plastic or metal protrusions of 0.4 mm maximum per side are not included.
2. Plastic interlead protrusions of 0.25 mm maximum per side are not included.

OUTLINE VERSION	REFERENCES			EUROPEAN PROJECTION	ISSUE DATE
	IEC	JEDEC	EIAJ		
SOT158-1					92-11-17 95-01-24

LCD drivers

PCF21xxC family

13 SOLDERING**13.1 Introduction**

There is no soldering method that is ideal for all IC packages. Wave soldering is often preferred when through-hole and surface mounted components are mixed on one printed-circuit board. However, wave soldering is not always suitable for surface mounted ICs, or for printed-circuits with high population densities. In these situations reflow soldering is often used.

This text gives a very brief insight to a complex technology. A more in-depth account of soldering ICs can be found in our "IC Package Databook" (order code 9398 652 90011).

13.2 DIP**13.2.1 SOLDERING BY DIPPING OR BY WAVE**

The maximum permissible temperature of the solder is 260 °C; solder at this temperature must not be in contact with the joint for more than 5 seconds. The total contact time of successive solder waves must not exceed 5 seconds.

The device may be mounted up to the seating plane, but the temperature of the plastic body must not exceed the specified maximum storage temperature ($T_{stg\ max}$). If the printed-circuit board has been pre-heated, forced cooling may be necessary immediately after soldering to keep the temperature within the permissible limit.

13.2.2 REPAIRING SOLDERED JOINTS

Apply a low voltage soldering iron (less than 24 V) to the lead(s) of the package, below the seating plane or not more than 2 mm above it. If the temperature of the soldering iron bit is less than 300 °C it may remain in contact for up to 10 seconds. If the bit temperature is between 300 and 400 °C, contact may be up to 5 seconds.

13.3 SO and VSO**13.3.1 REFLOW SOLDERING**

Reflow soldering techniques are suitable for all SO and VSO packages.

Reflow soldering requires solder paste (a suspension of fine solder particles, flux and binding agent) to be applied to the printed-circuit board by screen printing, stencilling or pressure-syringe dispensing before package placement.

Several techniques exist for reflowing; for example, thermal conduction by heated belt. Dwell times vary between 50 and 300 seconds depending on heating method. Typical reflow temperatures range from 215 to 250 °C.

Preheating is necessary to dry the paste and evaporate the binding agent. Preheating duration: 45 minutes at 45 °C.

13.3.2 WAVE SOLDERING

Wave soldering techniques can be used for all SO and VSO packages if the following conditions are observed:

- A double-wave (a turbulent wave with high upward pressure followed by a smooth laminar wave) soldering technique should be used.
- The longitudinal axis of the package footprint must be parallel to the solder flow.
- The package footprint must incorporate solder thieves at the downstream end.

During placement and before soldering, the package must be fixed with a droplet of adhesive. The adhesive can be applied by screen printing, pin transfer or syringe dispensing. The package can be soldered after the adhesive is cured.

Maximum permissible solder temperature is 260 °C, and maximum duration of package immersion in solder is 10 seconds, if cooled to less than 150 °C within 6 seconds. Typical dwell time is 4 seconds at 250 °C.

A mildly-activated flux will eliminate the need for removal of corrosive residues in most applications.

13.3.3 REPAIRING SOLDERED JOINTS

Fix the component by first soldering two diagonally-opposite end leads. Use only a low voltage soldering iron (less than 24 V) applied to the flat part of the lead. Contact time must be limited to 10 seconds at up to 300 °C. When using a dedicated tool, all other leads can be soldered in one operation within 2 to 5 seconds between 270 and 320 °C.

LCD drivers

PCF21xxC family

14 DEFINITIONS

Data sheet status	
Objective specification	This data sheet contains target or goal specifications for product development.
Preliminary specification	This data sheet contains preliminary data; supplementary data may be published later.
Product specification	This data sheet contains final product specifications.
Short-form specification	The data in this specification is extracted from a full data sheet with the same type number and title. For detailed information see the relevant data sheet or data handbook.
Limiting values	
Limiting values given are in accordance with the Absolute Maximum Rating System (IEC 134). Stress above one or more of the limiting values may cause permanent damage to the device. These are stress ratings only and operation of the device at these or at any other conditions above those given in the Characteristics sections of the specification is not implied. Exposure to limiting values for extended periods may affect device reliability.	
Application information	
Where application information is given, it is advisory and does not form part of the specification.	

15 LIFE SUPPORT APPLICATIONS

These products are not designed for use in life support appliances, devices, or systems where malfunction of these products can reasonably be expected to result in personal injury. Philips customers using or selling these products for use in such applications do so at their own risk and agree to fully indemnify Philips for any damages resulting from such improper use or sale.

Philips Semiconductors – a worldwide company

Argentina: see South America

Australia: 34 Waterloo Road, NORTH RYDE, NSW 2113,
Tel. +61 2 9805 4455, Fax. +61 2 9805 4466

Austria: Computerstr. 6, A-1101 WIEN, P.O. Box 213,
Tel. +43 1 60 101, Fax. +43 1 60 101 1210

Belarus: Hotel Minsk Business Center, Bld. 3, r. 1211, Volodarski Str. 6,
220050 MINSK, Tel. +375 172 200 733, Fax. +375 172 200 773

Belgium: see The Netherlands

Brazil: see South America

Bulgaria: Philips Bulgaria Ltd., Energoproject, 15th floor,
51 James Bourchier Blvd., 1407 SOFIA,
Tel. +359 2 689 211, Fax. +359 2 689 102

Canada: PHILIPS SEMICONDUCTORS/COMPONENTS,
Tel. +1 800 234 7381

China/Hong Kong: 501 Hong Kong Industrial Technology Centre,
72 Tat Chee Avenue, Kowloon Tong, HONG KONG,
Tel. +852 2319 7888, Fax. +852 2319 7700

Colombia: see South America

Czech Republic: see Austria

Denmark: Prags Boulevard 80, PB 1919, DK-2300 COPENHAGEN S,
Tel. +45 32 88 2636, Fax. +45 31 57 1949

Finland: Sinikalliontie 3, FIN-02630 ESPOO,
Tel. +358 9 615800, Fax. +358 9 61580/xxx

France: 4 Rue du Port-aux-Vins, BP317, 92156 SURESNES Cedex,
Tel. +33 1 40 99 6161, Fax. +33 1 40 99 6427

Germany: Hammerbrookstraße 69, D-20097 HAMBURG,
Tel. +49 40 23 53 60, Fax. +49 40 23 536 300

Greece: No. 15, 25th March Street, GR 17778 TAVROS/ATHENS,
Tel. +30 1 4894 339/239, Fax. +30 1 4814 240

Hungary: see Austria

India: Philips INDIA Ltd, Shivsagar Estate, A Block, Dr. Annie Besant Rd.
Worli, MUMBAI 400 018, Tel. +91 22 4938 541, Fax. +91 22 4938 722

Indonesia: see Singapore

Ireland: Newstead, Clonskeagh, DUBLIN 14,
Tel. +353 1 7640 000, Fax. +353 1 7640 200

Israel: RAPAC Electronics, 7 Kehilat Saloniki St, TEL AVIV 61180,
Tel. +972 3 645 0444, Fax. +972 3 649 1007

Italy: PHILIPS SEMICONDUCTORS, Piazza IV Novembre 3,
20124 MILANO, Tel. +39 2 6752 2531, Fax. +39 2 6752 2557

Japan: Philips Bldg 13-37, Kohnan 2-chome, Minato-ku, TOKYO 108,
Tel. +81 3 3740 5130, Fax. +81 3 3740 5077

Korea: Philips House, 260-199 Itaewon-dong, Yongsan-ku, SEOUL,
Tel. +82 2 709 1412, Fax. +82 2 709 1415

Malaysia: No. 76 Jalan Universiti, 46200 PETALING JAYA, SELANGOR,
Tel. +60 3 750 5214, Fax. +60 3 757 4880

Mexico: 5900 Gateway East, Suite 200, EL PASO, TEXAS 79905,
Tel. +9-5 800 234 7381

Middle East: see Italy

Netherlands: Postbus 90050, 5600 PB EINDHOVEN, Bldg. VB,
Tel. +31 40 27 82785, Fax. +31 40 27 88399

New Zealand: 2 Wagener Place, C.P.O. Box 1041, AUCKLAND,
Tel. +64 9 849 4160, Fax. +64 9 849 7811

Norway: Box 1, Manglerud 0612, OSLO,
Tel. +47 22 74 8000, Fax. +47 22 74 8341

Philippines: Philips Semiconductors Philippines Inc.,
106 Valero St. Salcedo Village, P.O. Box 2108 MCC, MAKATI,
Metro MANILA, Tel. +63 2 816 6380, Fax. +63 2 817 3474

Poland: Ul. Lukiska 10, PL 04-123 WARSZAWA,
Tel. +48 22 612 2831, Fax. +48 22 612 2327

Portugal: see Spain

Romania: see Italy

Russia: Philips Russia, Ul. Usatcheva 35A, 119048 MOSCOW,
Tel. +7 095 755 6918, Fax. +7 095 755 6919

Singapore: Lorong 1, Toa Payoh, SINGAPORE 1231,
Tel. +65 350 2538, Fax. +65 251 6500

Slovakia: see Austria

Slovenia: see Italy

South Africa: S.A. PHILIPS Pty Ltd., 195-215 Main Road Martindale,
2092 JOHANNESBURG, P.O. Box 7430 Johannesburg 2000,
Tel. +27 11 470 5911, Fax. +27 11 470 5494

South America: Rua do Rocio 220, 5th floor, Suite 51,
04552-903 São Paulo, SÃO PAULO - SP, Brazil,
Tel. +55 11 821 2333, Fax. +55 11 829 1849

Spain: Balmes 22, 08007 BARCELONA,
Tel. +34 3 301 6312, Fax. +34 3 301 4107

Sweden: Kottbygatan 7, Akalla, S-16485 STOCKHOLM,
Tel. +46 8 632 2000, Fax. +46 8 632 2745

Switzerland: Allmendstrasse 140, CH-8027 ZÜRICH,
Tel. +41 1 488 2686, Fax. +41 1 481 7730

Taiwan: Philips Semiconductors, 6F, No. 96, Chien Kuo N. Rd., Sec. 1,
TAIPEI, Taiwan Tel. +886 2 2134 2870, Fax. +886 2 2134 2874

Thailand: PHILIPS ELECTRONICS (THAILAND) Ltd.,
209/2 Sanpavuth-Bangna Road Prakanong, BANGKOK 10260,
Tel. +66 2 745 4090, Fax. +66 2 398 0793

Turkey: Talatpasa Cad. No. 5, 80640 GÜLTEPE/ISTANBUL,
Tel. +90 212 279 2770, Fax. +90 212 282 6707

Ukraine: PHILIPS UKRAINE, 4 Patrice Lumumba str., Building B, Floor 7,
252042 KIEV, Tel. +380 44 264 2776, Fax. +380 44 268 0461

United Kingdom: Philips Semiconductors Ltd., 276 Bath Road, Hayes,
MIDDLESEX UB3 5BX, Tel. +44 181 730 5000, Fax. +44 181 754 8421

United States: 811 East Arques Avenue, SUNNYVALE, CA 94088-3409,
Tel. +1 800 234 7381

Uruguay: see South America

Vietnam: see Singapore

Yugoslavia: PHILIPS, Trg N. Pasica 5/v, 11000 BEOGRAD,
Tel. +381 11 625 344, Fax. +381 11 635 777

For all other countries apply to: Philips Semiconductors, Marketing & Sales Communications,
Building BE-p, P.O. Box 218, 5600 MD EINDHOVEN, The Netherlands, Fax. +31 40 27 24825

Internet: <http://www.semiconductors.philips.com>

© Philips Electronics N.V. 1997

SCA53

All rights are reserved. Reproduction in whole or in part is prohibited without the prior written consent of the copyright owner.

The information presented in this document does not form part of any quotation or contract, is believed to be accurate and reliable and may be changed without notice. No liability will be accepted by the publisher for any consequence of its use. Publication thereof does not convey nor imply any license under patent- or other industrial or intellectual property rights.

Printed in The Netherlands

417067/1200/02/pp24

Date of release: 1997 Mar 28

Document order number: 9397 750 01649

Let's make things better.

Philips
Semiconductors



PHILIPS