

DATA SHEET

TDA8559

Low-voltage stereo headphone amplifier

Product specification
Supersedes data of 1996 Jan 02
File under Integrated Circuits, IC01

1997 Jun 27

Low-voltage stereo headphone amplifier

TDA8559

FEATURES

- Operating voltage from 1.9 to 30 V
- Very low quiescent current
- Low distortion
- Few external components
- Differential inputs
- Usable as a mono amplifier in Bridge-Tied Load (BTL) or stereo Single-Ended (SE)
- Single-ended mode without loudspeaker capacitor
- Mute and standby mode
- Short-circuit proof to ground, to supply voltage (<10 V) and across load
- No switch on or switch off clicks
- ESD protected on all pins.

APPLICATIONS

- Portable telephones
- Walk-mans
- Portable audio
- Mains fed equipment.

GENERAL DESCRIPTION

The TDA8559 is a stereo amplifier that operates over a wide supply voltage range from 1.9 to 30 V and consumes a very low quiescent current. This makes it suitable for battery fed applications (2×1.5 V cells). Because of an internal voltage buffer, this device can be used with or without a capacitor connected in series with the load. It can be applied as a headphone amplifier, but also as a mono amplifier with a small speaker (25Ω), or as a line driver in mains applications.

QUICK REFERENCE DATA

SYMBOL	PARAMETER	CONDITIONS	MIN.	TYP.	MAX.	UNIT
Supplies						
V_P	operating supply voltage		1.9	3	30	V
$I_{q(\text{tot})}$	total quiescent current		–	2.75	4	mA
I_{stb}	standby supply current		–	–	10	μA
Stereo application						
P_o	output power	THD = 10%	30	35	–	mW
THD	total harmonic distortion	$P_o = 20$ mW; $f_i = 1$ kHz	–	0.075	0.15	%
		$P_o = 20$ mW; $f_i = 10$ kHz	–	0.1	–	%
G_v	voltage gain		25	26	27	dB
f_{ss}	small signal roll-off frequency	–1 dB	–	750	–	kHz
BTL application						
P_o	output power	THD = 10%	125	140	–	mW
THD	total harmonic distortion	$P_o = 70$ mW; $f_i = 1$ kHz	–	0.05	0.1	%
		$P_o = 70$ mW; $f_i = 10$ kHz	–	0.2	–	%
G_v	voltage gain		31	32	33	dB

ORDERING INFORMATION

TYPE NUMBER	PACKAGE		
	NAME	DESCRIPTION	VERSION
TDA8559	DIP16	plastic dual in-line package; 16 leads (300 mil); long body	SOT38-1
TDA8559T	SO16	plastic small outline package; 16 leads; body width 3.9 mm	SOT109-1

Low-voltage stereo headphone amplifier

TDA8559

BLOCK DIAGRAM

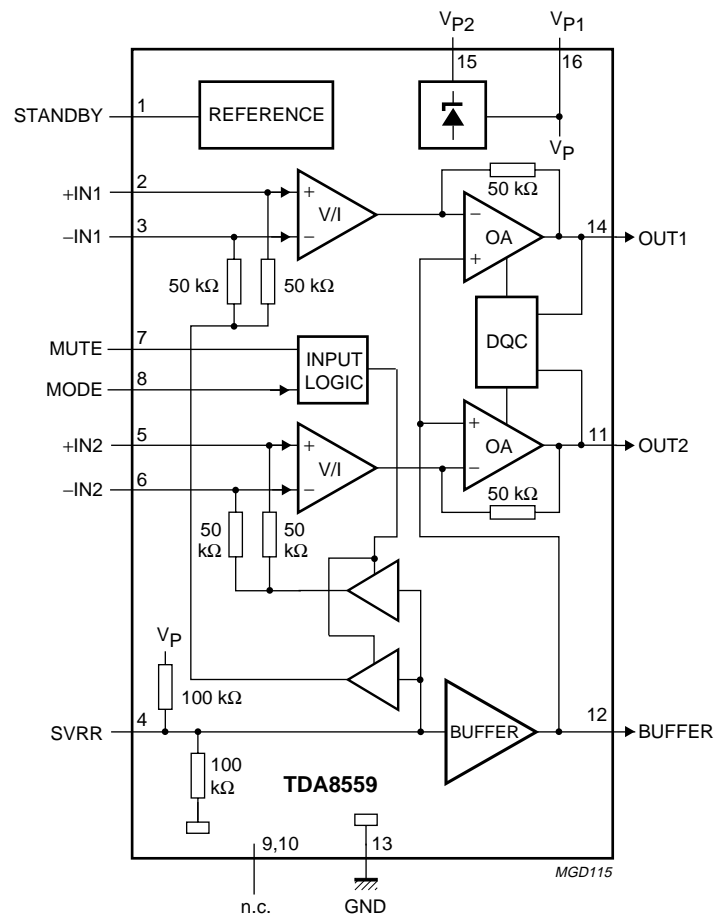

Fig.1 Block diagram.

Low-voltage stereo headphone amplifier

TDA8559

PINNING

SYMBOL	PIN	DESCRIPTION
STANDBY	1	standby select
+IN1	2	non-inverting input 1
-IN1	3	inverting input 1
SVRR	4	supply voltage ripple rejection
+IN2	5	non-inverting input 2
-IN2	6	inverting input 2
MUTE	7	mute select
MODE	8	input mode select
n.c.	9	not connected
n.c.	10	not connected
OUT2	11	output 2
BUFFER	12	buffer output (0.5V _P)
GND	13	ground
OUT1	14	output 1
V _{P2}	15	high supply voltage
V _{P1}	16	low supply voltage

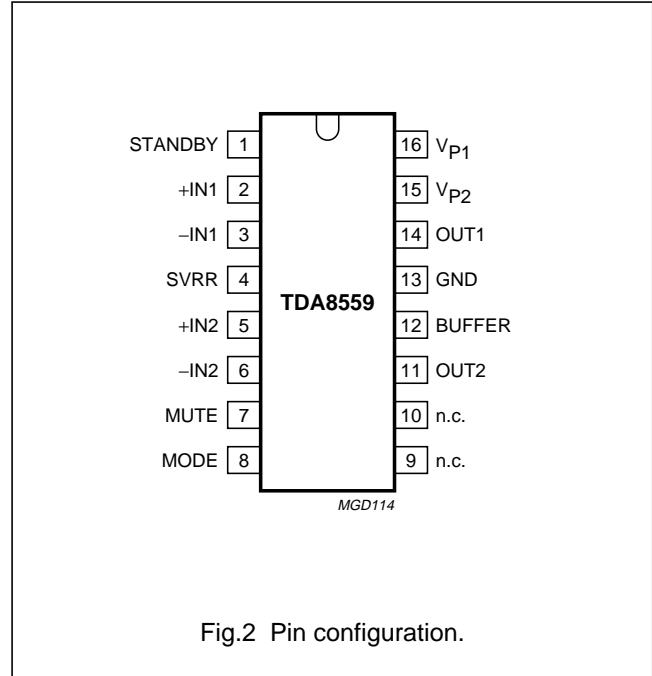

Fig.2 Pin configuration.

FUNCTIONAL DESCRIPTION

The TDA8559 contains two amplifiers with differential inputs, a 0.5V_P output buffer and a high supply voltage stabilizer. Each amplifier consists of a voltage-to-current converter (V/I), an output amplifier and a common dynamic quiescent current controller. The gain of each amplifier is internally fixed at 26 dB (= 20 ×). The 0.5V_P output can be used as a replacement for the single-ended capacitors. The two amplifiers can also be used as a mono amplifier in a BTL configuration thereby resulting in more output power.

With three mode select pins, the device can be switched into the following modes:

1. Standby mode (I_P < 10 μA)
2. Mute mode
3. Operation mode, with two input selections (the input source is directly connected or connected via coupling capacitors at the input).

The ripple rejection in the stereo application with a single-ended capacitor can be improved by connecting a capacitor between the 0.5V_P capacitor pin and ground.

The device is fully protected against short-circuiting of the output pins to ground, to the low supply voltage pin and across the load.

V/I converters

The V/I converters have a transconductance of 400 μS. The inputs are completely symmetrical and the two amplifiers can be used in opposite phase. The mute mode causes the V/I converters to block the input signal. The input mode pin selects two applications in which the V/I converters can be used.

The first application (input mode pin floating) is used with a supply voltage below 6 V. The input DC level is at ground level (the unused input pin connected to ground) and no input coupling capacitors are necessary. The maximum converter output current is sufficient to obtain an output swing of 3 V (peak).

In the second application with a supply voltage greater than 6 V (input mode pin HIGH), the input mode pin is connected to V_P. In this configuration (input DC level = 0.5V_P + 0.6 V) the input source must be coupled with a capacitor and the two unused input pins must be connected via a capacitor to ground, to improve noise performance. This application has a higher quiescent current, because the maximum output current of the V/I converter is higher to obtain an output voltage swing of 9 V (peak).

Low-voltage stereo headphone amplifier

TDA8559

Output amplifiers

The output amplifiers have a transresistance of 50 k Ω , a bandwidth of approximately 750 kHz and a maximum output current of 100 mA. The mid-tap output voltage equals the voltage applied at the non-inverting pin of the output amplifier. This pin is connected to the output of the 0.5V_P buffer. This reduces the distortion when the load is connected between an output amplifier and the buffer (because feedback is applied over the load).

Buffer

The buffer delivers 0.5V_P to the output with a maximum output (sink and source) current of 200 mA (peak).

Dynamic quiescent controller

The Dynamic Quiescent Current controller (DQC) gives the advantage of low quiescent current and low distortion. When there are high frequencies in the output signal, the DQC will increase the quiescent current of the two output amplifiers and the buffer. This will reduce the cross-over distortion that normally occurs at high frequencies and low quiescent current. The DQC gives output currents that are linear with the amplitude and the frequency of the output signals. These currents control the quiescent current.

Stabilizer

The TDA8559 has a voltage supply range from 1.9 to 30 V. This range is divided over two supply voltage pins. Pin 16 is 1.9 to 18 V (breakdown voltage of the process); this pin is preferred for supply voltages less than 18 V. Pin 15 is used for applications where V_P is approximately 6 to 30 V. The stabilizer output is internally connected to the supply voltage pin 16. In the range from 6 to 18 V, the voltage drop to pin 16 is 1 V. In the range from 18 to 30 V the stabilizer output voltage (to pin 16) is approximately 17 V.

Input logic

The MUTE pin (pin 7) selects the mute mode of the V/I converters. LOW (TTL/CMOS) level is mute. A voltage between 0.5 V (low level) and 1.5 V (high level) causes a soft mute to operate (no plops). When pin 7 is floating or greater than 1.5 V it is in the operating condition.

The input mode pin must be connected to V_P when the supply voltage is greater than 6 V. The input mode logic raises the tail current of the V/I converters and enables the two buffers to bias the inputs of the V/I converters.

Reference

This circuit supplies all currents needed in this device. With the standby mode pin 1 (TTL/CMOS), it is possible to switch to the standby mode and reduce the total quiescent current to below 10 μ A.

Low-voltage stereo headphone amplifier

TDA8559

LIMITING VALUES

In accordance with the Absolute Maximum Rating System (IEC 134).

SYMBOL	PARAMETER	CONDITIONS	MIN.	MAX.	UNIT
$V_{P2(max)}$	maximum supply voltage (pin 15)		–	30	V
$V_{P1(max)}$	maximum supply voltage (pin 16)		–	18	V
$V_{i(max)}$	maximum input voltage		–	18	V
I_{ORM}	peak output current	repetitive	–	150	mA
P_{tot}	total power dissipation	SO16	–	1.19	W
		DIP16	–	2.4	W
T_{amb}	operating ambient temperature		–40	+85	°C
T_{stg}	storage temperature		–55	+150	°C
T_{vj}	virtual junction temperature		–	150	°C
t_{sc}	short-circuiting time	$V_P < 10\text{ V}$	–	1	hour

QUALITY SPECIFICATION

Quality in accordance with "SNW-FQ-611E", if this type is used as an audio amplifier. The number of the quality specification can be found in the "Quality Reference handbook". The handbook can be ordered using the code 9397 750 00192.

THERMAL CHARACTERISTICS

SYMBOL	DESCRIPTION	VALUE	UNIT
$R_{th\ j-a}$	thermal resistance from junction to ambient in free air		
	DIP16	52	K/W
	SO16	105	K/W

CHARACTERISTICS

$V_P = 3\text{ V}$; $T_{amb} = 25\text{ °C}$; $f_i = 1\text{ kHz}$; unless otherwise specified.

SYMBOL	PARAMETER	CONDITIONS	MIN.	TYP.	MAX.	UNIT
DC characteristics						
V_P	operating supply voltage	note 1	1.9	3	30	V
$I_{q(tot)}$	total quiescent current	open load	–	2.75	4	mA
I_{stb}	standby supply current	open load	–	–	10	μA
V_1	standby mode voltage	standby	0	–	0.5	V
		operating	1.5	–	18	V
V_7	mute mode voltage	mute	0	–	0.5	V
		operating	1.5	–	18	V
I_{bias}	input bias current		–	100	300	nA

Low-voltage stereo headphone amplifier

TDA8559

SYMBOL	PARAMETER	CONDITIONS	MIN.	TYP.	MAX.	UNIT
Single-ended stereo application ($R_L = 32 \Omega$)						
P_o	output power	THD = 10%	30	35	–	mW
THD	total harmonic distortion	$P_o = 20 \text{ mW}; f_i = 1 \text{ kHz}; \text{ note 2}$	–	0.075	0.15	%
		$P_o = 20 \text{ mW}; f_i = 10 \text{ kHz}; \text{ note 2}$	–	0.1	–	%
G_v	voltage gain		25	26	27	dB
f_{ss}	small signal roll-off frequency	–1 dB	–	750	–	kHz
α_{cs}	channel separation	$R_s = 5 \text{ k}\Omega$	40	–	–	dB
$ \Delta G_v $	channel unbalance		–	–	1	dB
V_{no}	noise output voltage	note 3	–	70	85	μV
$V_{no(mute)}$	noise output voltage in mute	note 3	–	20	30	μV
$V_{o(mute)}$	output voltage in mute	note 4	–	–	30	μV
V_{mt}	mid-tap voltage		1.4	1.5	1.6	V
Z_i	input impedance		75	100	125	$\text{k}\Omega$
V_{os}	DC output offset voltage	note 5	–	–	100	mV
SVRR	supply voltage ripple rejection	note 6	45	55	–	dB
BTL application ($R_L = 25 \Omega$)						
P_o	output power	THD = 10%	125	140	–	mW
THD	total harmonic distortion	$P_o = 70 \text{ mW}; f_i = 1 \text{ kHz}; \text{ note}$	–	0.05	0.1	%
		$P_o = 70 \text{ mW}; f_i = 10 \text{ kHz}; \text{ note 2}$	–	0.1	–	%
G_v	voltage gain		31	32	33	dB
f_{ss}	small signal roll-off frequency	–1 dB	–	750	–	kHz
V_{no}	noise output voltage	note 3	–	100	120	μV
$V_{no(mute)}$	noise output voltage in mute	note 3	–	25	40	μV
$V_{o(mute)}$	output voltage in mute	note 4	–	–	40	μV
V_{os}	DC output offset voltage	note 7	–	–	150	mv
SVRR	supply voltage ripple rejection	note 6	39	49	–	dB
Z_i	input impedance		39	50	61	$\text{k}\Omega$
Line driver application ($R_L \geq 1 \text{ k}\Omega$)						
V_o	line output voltage		0.1	–	2.9	V

Notes

1. The supply voltage range at pin V_{P1} is from 1.9 to 18 V. Pin V_{P2} is used for the voltage range from 6 to 30 V.
2. Measured with low-pass filter 30 kHz.
3. Noise output voltage measured with a bandwidth of 20 Hz to 20 kHz, unweighted. $R_s = 5 \text{ k}\Omega$.
4. RMS output voltage in mute is measured with $V_i = 200 \text{ mV}$ (RMS); $f = 1 \text{ kHz}$.
5. DC output offset voltage is measured between the signal output and the $0.5V_P$ output.
6. The ripple rejection is measured with a ripple voltage of 200 mV (RMS) applied to the positive supply rail ($R_s = 0 \text{ k}\Omega$).
7. DC output offset voltage is measured between the two signal outputs.

Low-voltage stereo headphone amplifier

TDA8559

APPLICATION INFORMATION

General

For applications with a maximum supply voltage of 6 V (input mode LOW) the input pins need a DC path to ground (see Figs 3 and 4). For applications with supply voltages in the range from 6 to 18 V (input mode HIGH) the input DC level is $0.5V_P + 0.6$ V. In this situation the input configurations illustrated in Figs 5 and 6 have to be used.

The capacitor C_b is recommended for stability improvement. The value may vary between 10 and 100 nF. This capacitor should be placed close to the IC between pin 12 and pin 13.

Heatsink design

The standard application is stereo headphone single-ended with a 32Ω load impedance to buffer (see Fig.9). The headphone amplifier can deliver a peak output current of 150 mA into the load.

For the DIP16 envelope $R_{th\ j-amb} = 52$ K/W; the maximum sine wave power dissipation for $T_{amb} = 25$ °C is:

$$2.4\ W = \frac{150 - 25}{52}$$

For $T_{amb} = 60$ °C the maximum total power dissipation is:

$$1.7\ W = \frac{150 - 60}{52}$$

For the SO16 envelope $R_{th\ j-amb} = 105$ K/W; the maximum sinewave power dissipation for $T_{amb} = 25$ °C is:

$$1.2\ W = \frac{150 - 25}{105}$$

For $T_{amb} = 60$ °C the maximum total power dissipation is:

$$0.85\ W = \frac{150 - 60}{105}$$

Test conditions

$T_{amb} = 25$ °C; unless otherwise specified: $V_P = 3$ V, $f = 1$ kHz, $R_L = 32 \Omega$, Gain = 26 dB, low input mode, band-pass filter: 22 Hz to 30 kHz. The total harmonic distortion as a function of frequency was measured with low-pass filter of 80 kHz. The quiescent current has been measured without any load impedance.

In applications with coupling capacitors towards the load, an electrolytic capacitor has to be connected to pin 4 (SVRR).

- The graphs for the single-ended application have been measured with the application illustrated in Fig.9; input configuration for input mode low (Fig.4) and input configuration for input mode high (Fig.6).
- The graphs for the BTL application 'input mode low' have been measured with the application circuit illustrated in Fig.11 and the input configuration illustrated in Fig.4.
- The graphs for the line-driver application have been measured with the application circuit illustrated in Fig.13 and the input configuration illustrated in Fig.6; input mode high.

Input configurations

The IC can be applied in two ways, 'input mode low' and 'input mode high'. This can be selected by the input mode at pin 8:

1. Input mode low: pin 8 floating:
The DC level of the input pins has to be between 0 V and $(V_P - 1.8)$ V. A DC path to ground is needed. The maximum output voltage is approximately 2.1 V (RMS). Input configurations illustrated in Figs 3 and 4 should be used.
2. Input mode high: pin 8 is connected to V_P :
This mode is intended for supply voltages >6 V. It can deliver a maximum output voltage of approximately 6 V (RMS) at THD = 0.5%. The DC voltage level of the input pins is $(0.5V_P + 0.6)$ V. Coupling capacitors are necessary. Input configurations illustrated in Figs 5 and 6 should be used.

Low-voltage stereo headphone amplifier

TDA8559

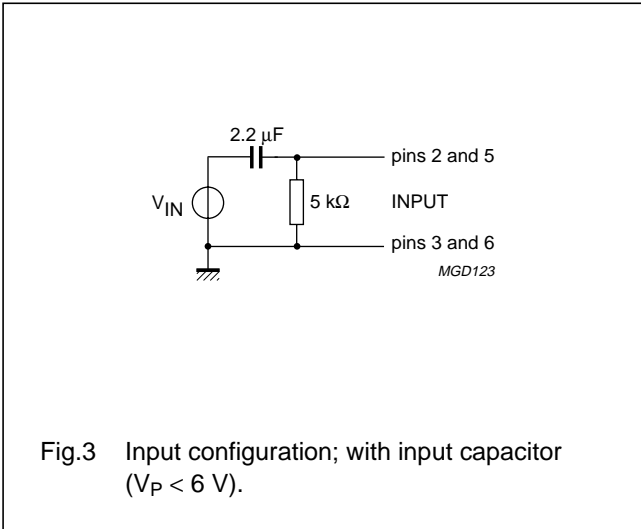

Fig. 3 Input configuration; with input capacitor ($V_P < 6\text{ V}$).

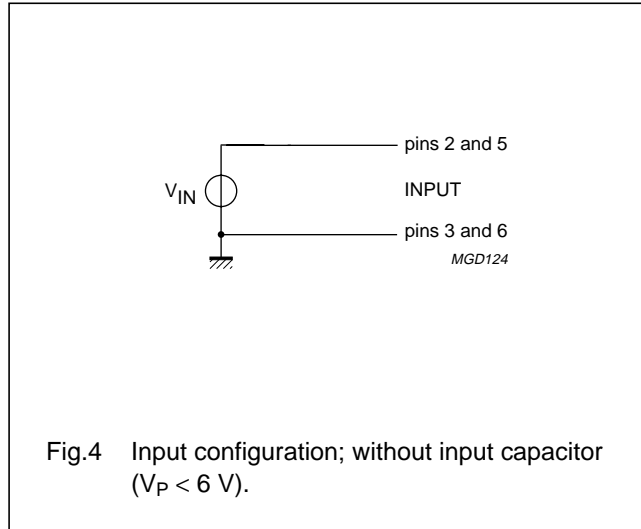

Fig. 4 Input configuration; without input capacitor ($V_P < 6\text{ V}$).

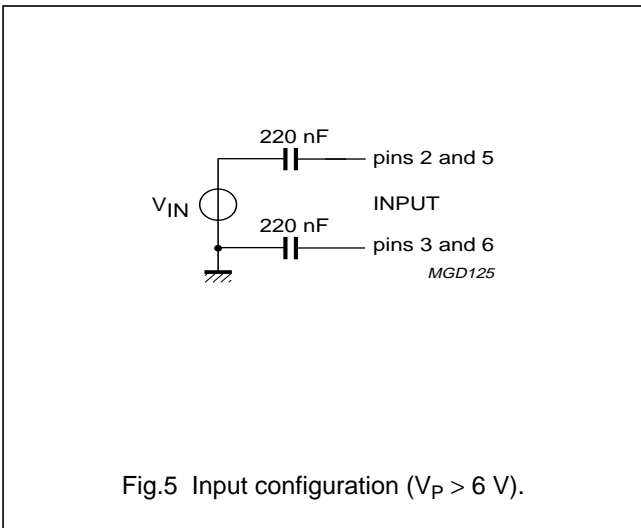

Fig. 5 Input configuration ($V_P > 6\text{ V}$).

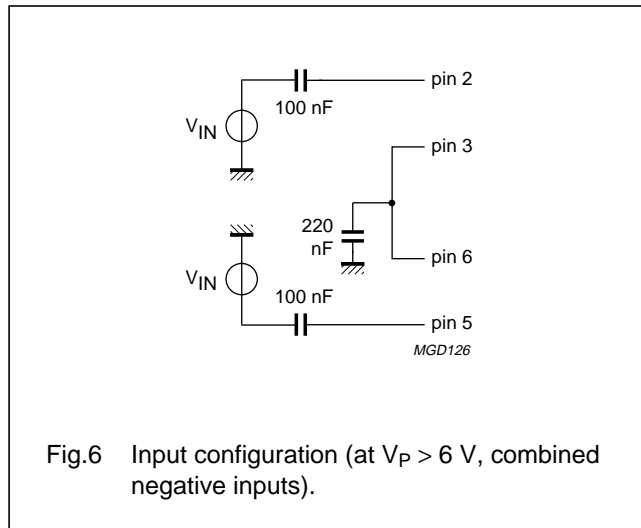

Fig. 6 Input configuration (at $V_P > 6\text{ V}$, combined negative inputs).

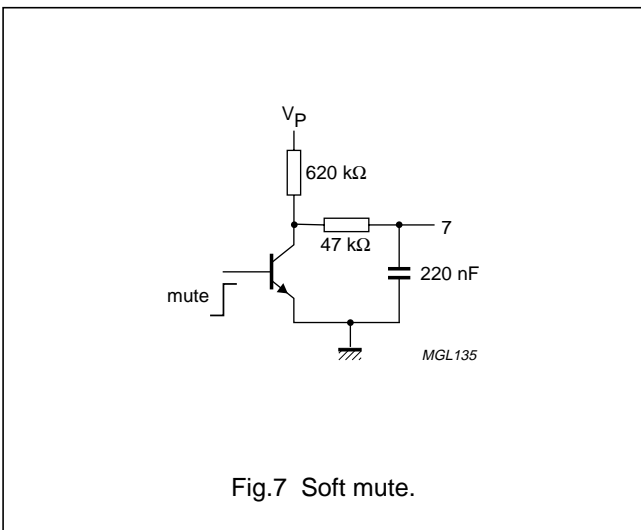

Fig. 7 Soft mute.

Standby/mute

- The standby mode ($V_1 < 0.5\text{ V}$) is intended for power saving purpose. Then the total quiescent current is $< 10\text{ }\mu\text{A}$.
- To avoid 'pop-noise' during switch-on or switch-off the IC can be muted ($V_7 < 0.5\text{ V}$). This can be achieved by a 'soft-mute' circuit or by direct control from a microcontroller.

Low-voltage stereo headphone amplifier

TDA8559

Application 1: SE with loudspeaker capacitor (see Fig.8)

The value of capacitor C_r influences the behaviour of the Supply Voltage Ripple Rejection (SVRR) at low frequencies; increasing the value of C_r increases the performance of the SVRR.

Application 2: SE to buffer (without loudspeaker capacitor) (see Fig.9)

This is the basic headphone application. The advantage of this application with respect to application 1, is that it needs only one external component (C_b) in the event of stability problems.

Application 3: Improved SE to buffer (without loudspeaker capacitor) (see Fig.10)

This application is an improved configuration of application 2. The distinction between the two is connecting the loads in opposite phase. This lowers the average current through the SE buffer.

It should be noted that a headphone cannot be used because the load requires floating terminals.

Application 4: Bridge tied load mono amplifier (see Fig.11)

This configuration delivers four times the output power of the SE application with the same supply and load conditions. The capacitor C_r is not required.

Application 5: Line driver application $1.9\text{ V} < V_P < 6\text{ V}$ (see Fig.12)

The TDA8559 delivers a virtual rail-to-rail output voltage and is also usable in a low voltage environment, as a line driver. In this application the input needs a DC path to ground, input configurations illustrated in Figs 3 and 4 should be used. The value of capacitor C_r influences the behaviour of the SVRR at low frequencies; increasing the value of C_r increases the performance of the SVRR.

Application 6: Line driver application $6\text{ V} < V_P < 18\text{ V}$ (see Fig.13)

The TDA8559T delivers a virtual rail-to-rail output voltage. Because the input mode has to be high, the input configurations illustrated in Figs 5 and 6 should be used. This application can also be used for headphone application, however, due to the limited output current and the limited output power at the headphone, series resistors have to be used between the output pins and the load.

The value of capacitor C_r influences the behaviour of the SVRR at low frequencies; increasing the value of C_r increases the performance of the SVRR.

Application 7: Line driver application $6\text{ V} < V_P < 30\text{ V}$ (see Fig.14)

With the supply voltage connected to pin 15 it is possible to use the head amplifier above the maximum of 18 V to pin 16. The internal supply voltage will be reduced to a maximum of approximately 17 V.

This will be convenient in applications where the supply voltage is higher than 18 V, however an output voltage swing that reaches the higher supply voltage is not required. The input configurations illustrated in Figs 5 and 6 should be used. This application can also be used for headphone applications. However, due to the limited output current, series resistors have to be used between the output pins and the load.

Low-voltage stereo headphone amplifier

TDA8559

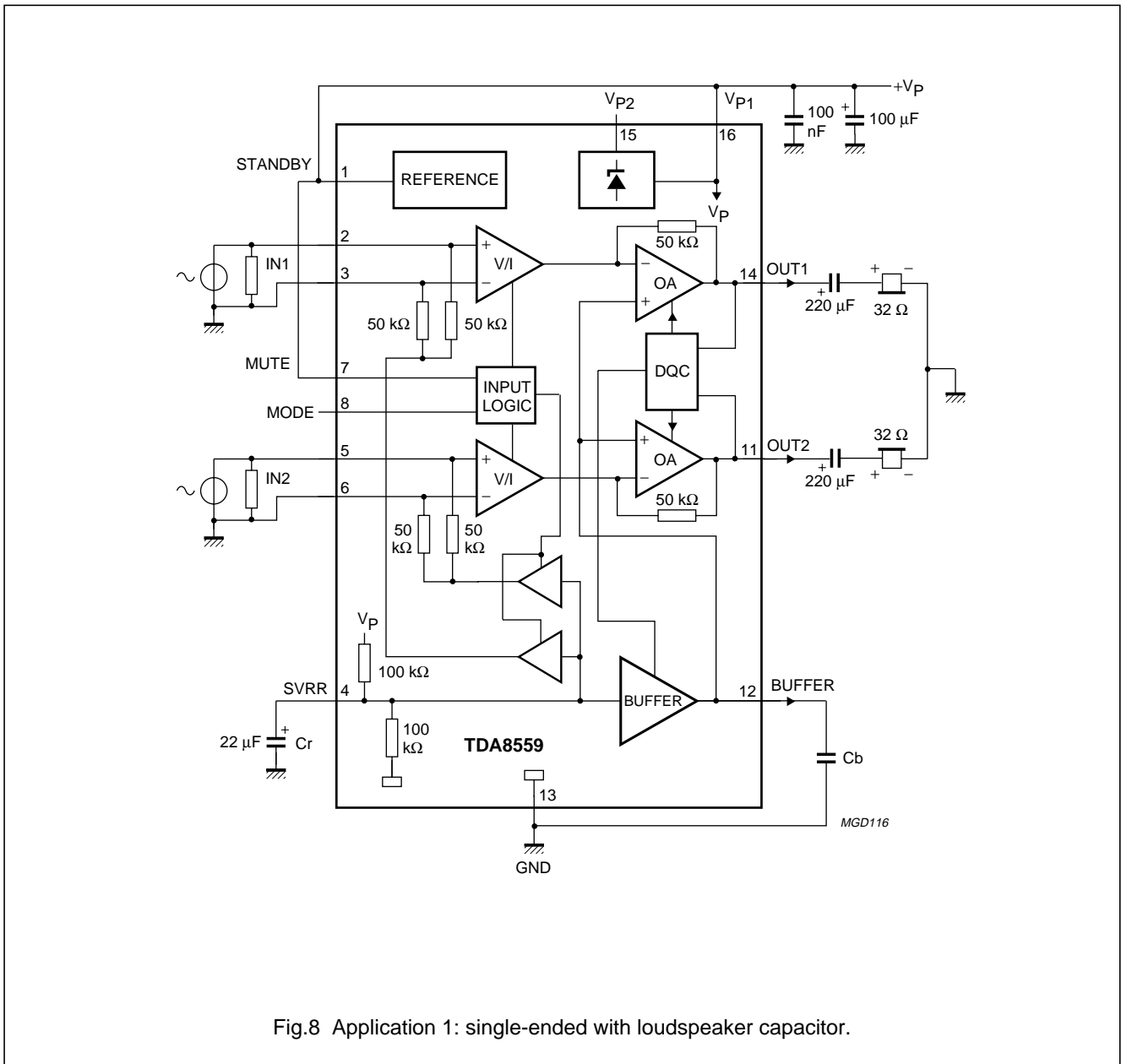

Fig.8 Application 1: single-ended with loudspeaker capacitor.

Low-voltage stereo headphone amplifier

TDA8559

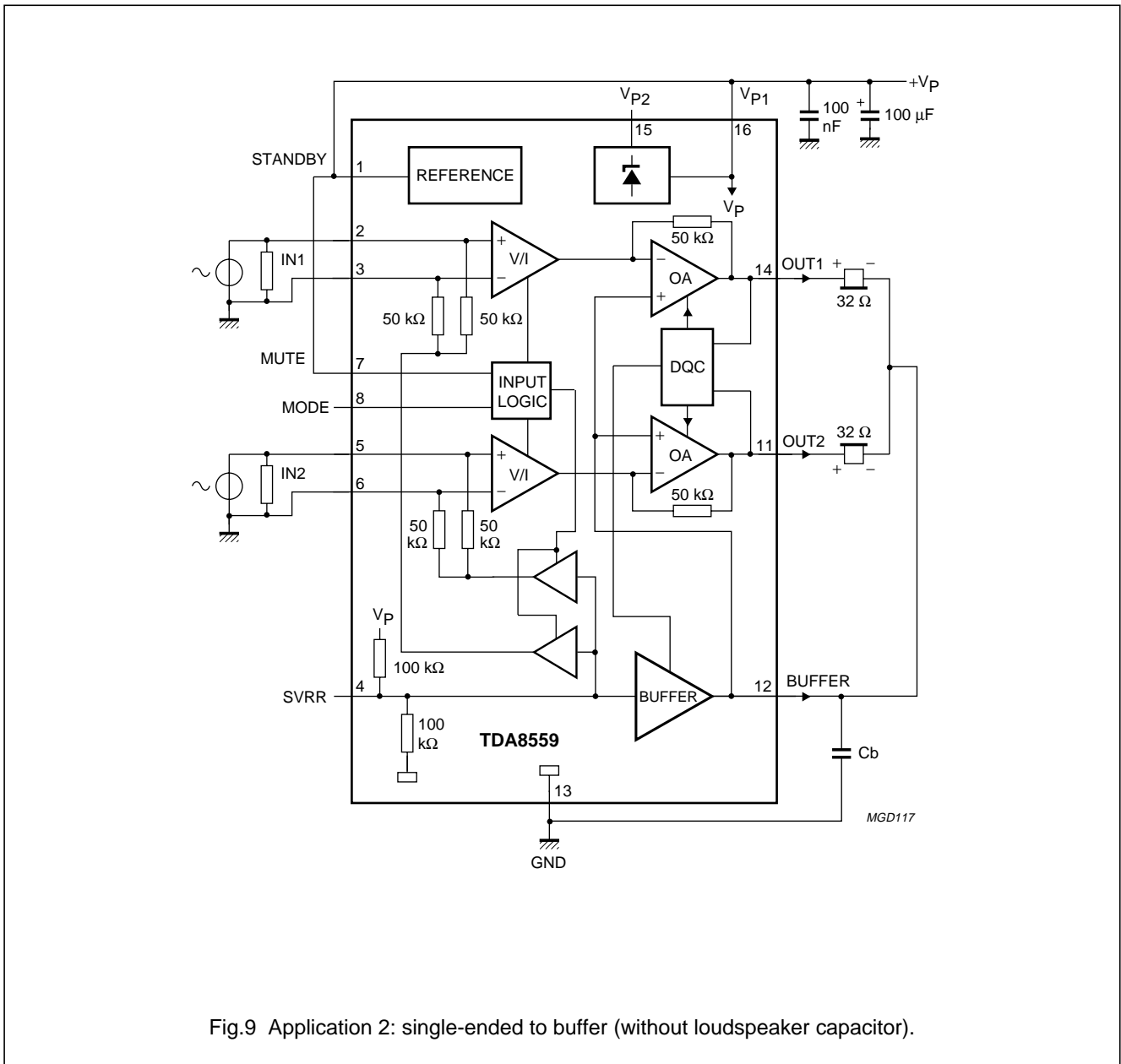

Fig.9 Application 2: single-ended to buffer (without loudspeaker capacitor).

Low-voltage stereo headphone amplifier

TDA8559

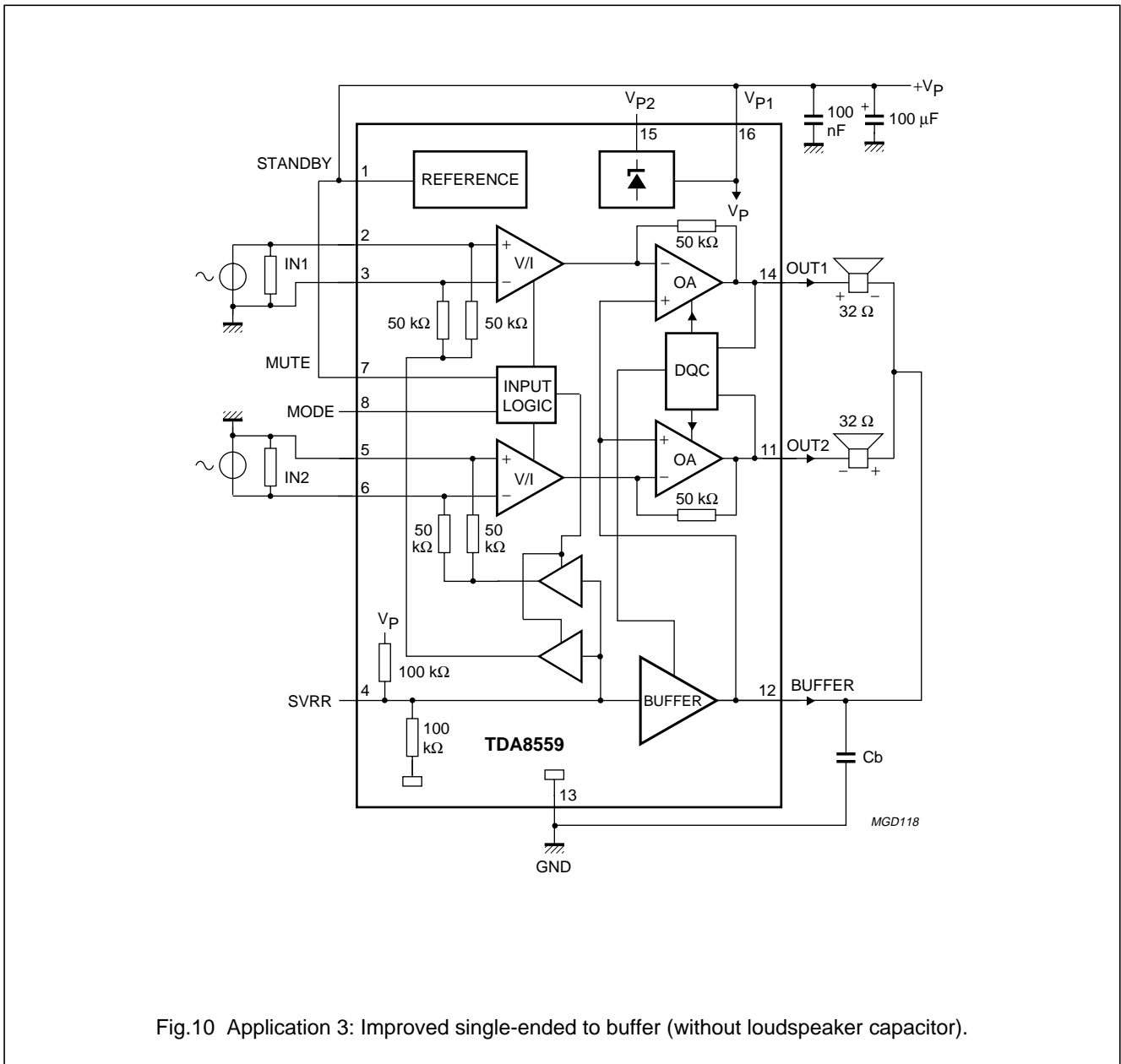

Fig.10 Application 3: Improved single-ended to buffer (without loudspeaker capacitor).

Low-voltage stereo headphone amplifier

TDA8559

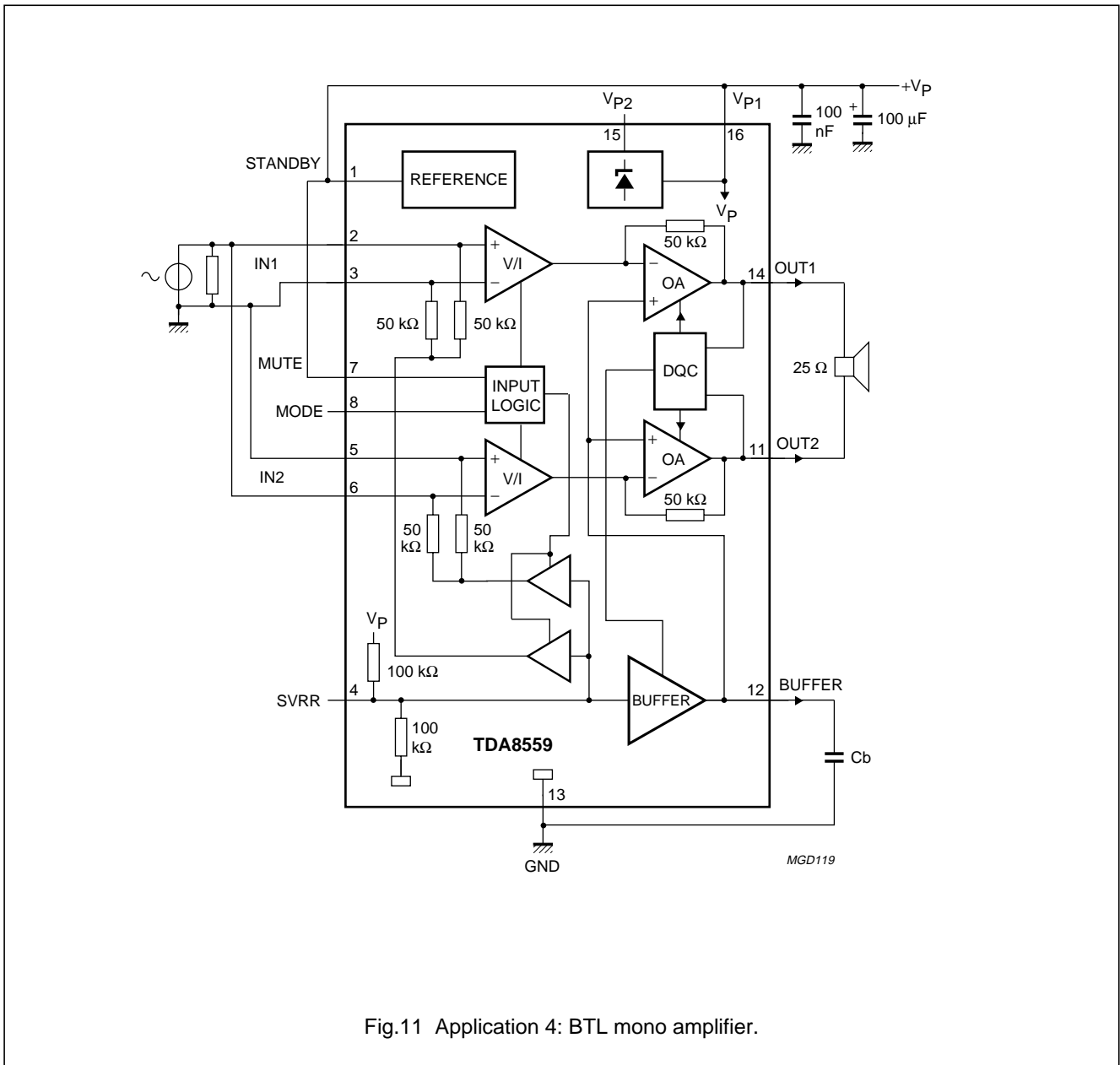

Fig.11 Application 4: BTL mono amplifier.

Low-voltage stereo headphone amplifier

TDA8559

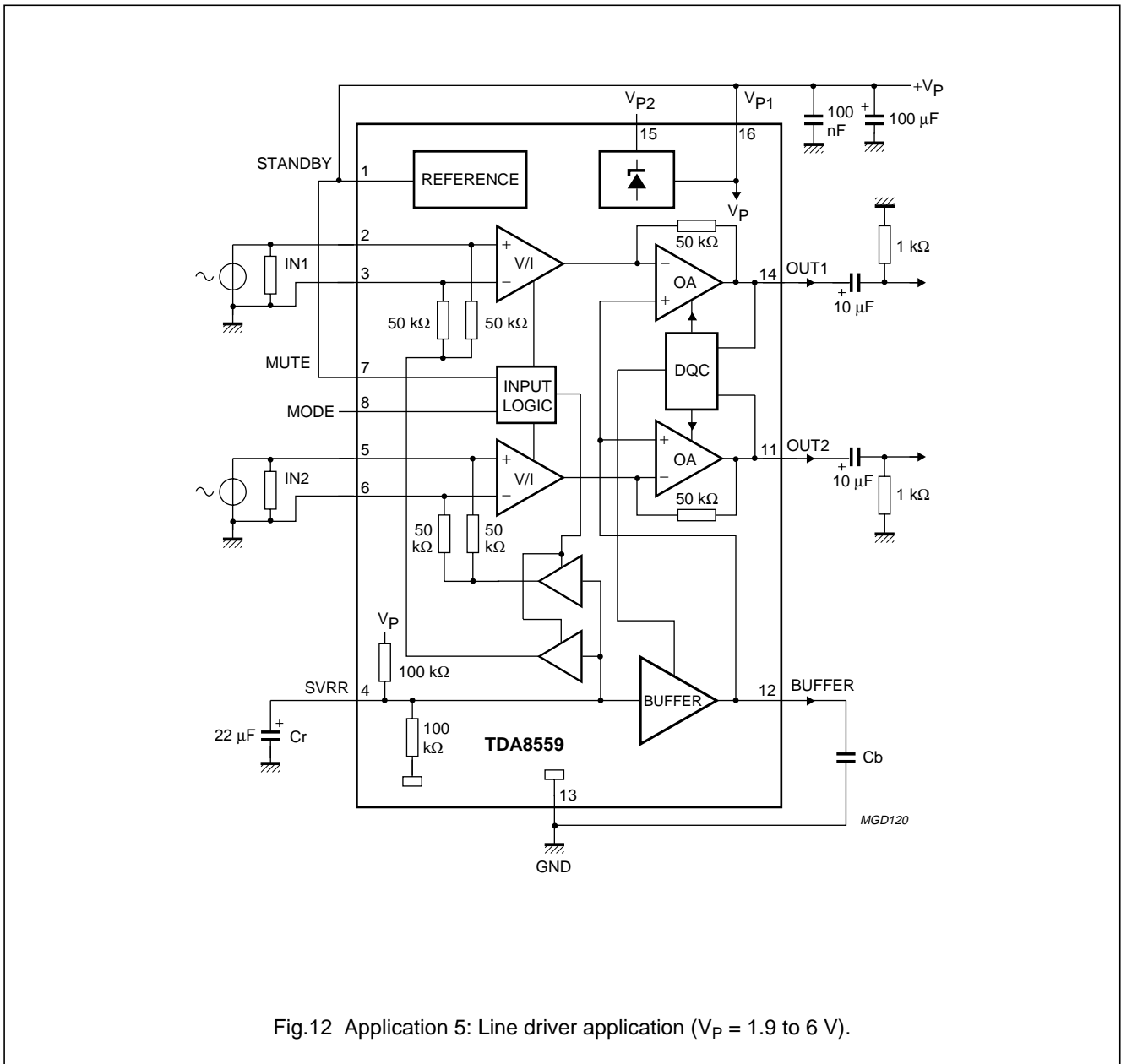

Fig.12 Application 5: Line driver application ($V_P = 1.9$ to 6 V).

Low-voltage stereo headphone amplifier

TDA8559

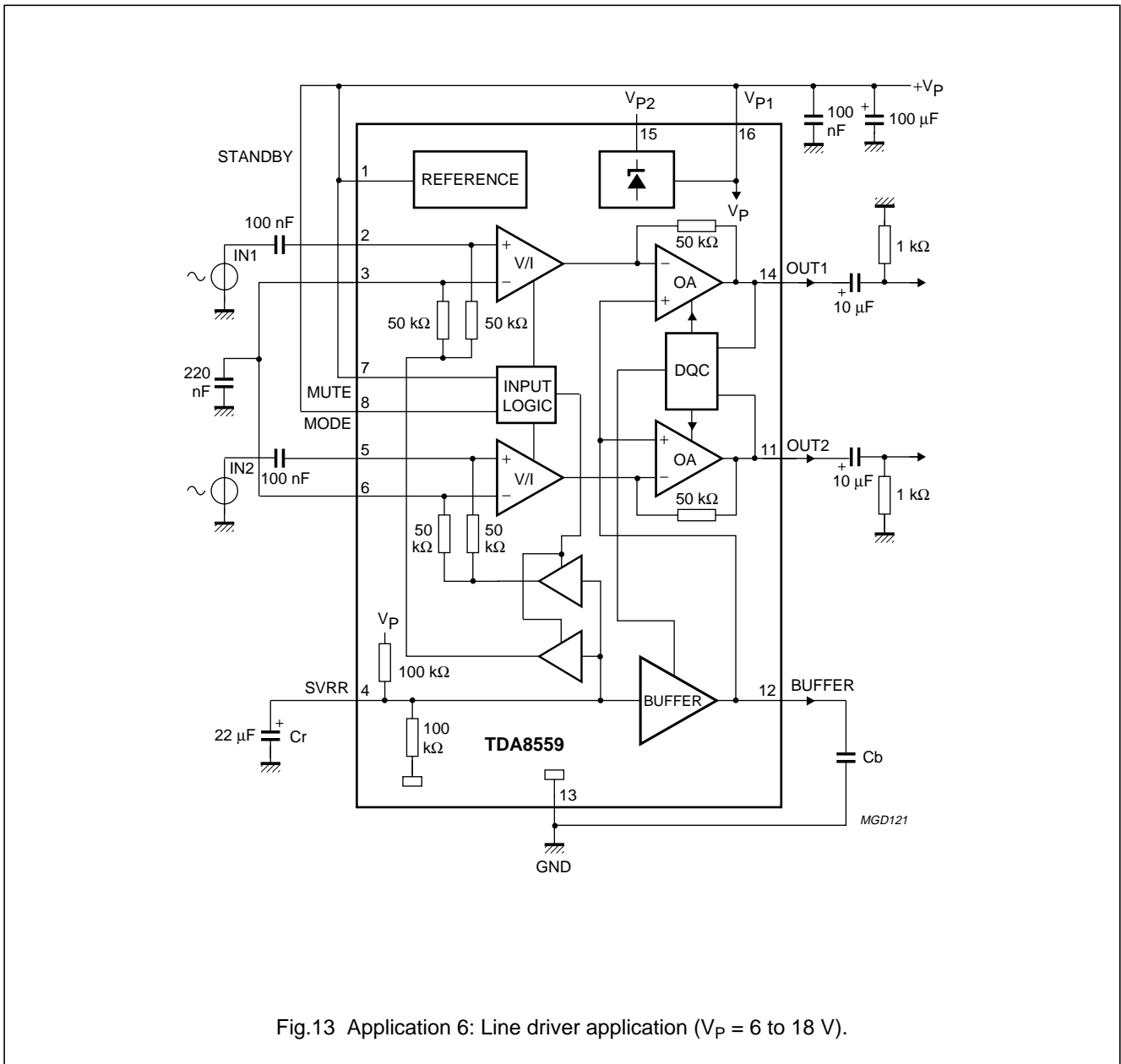
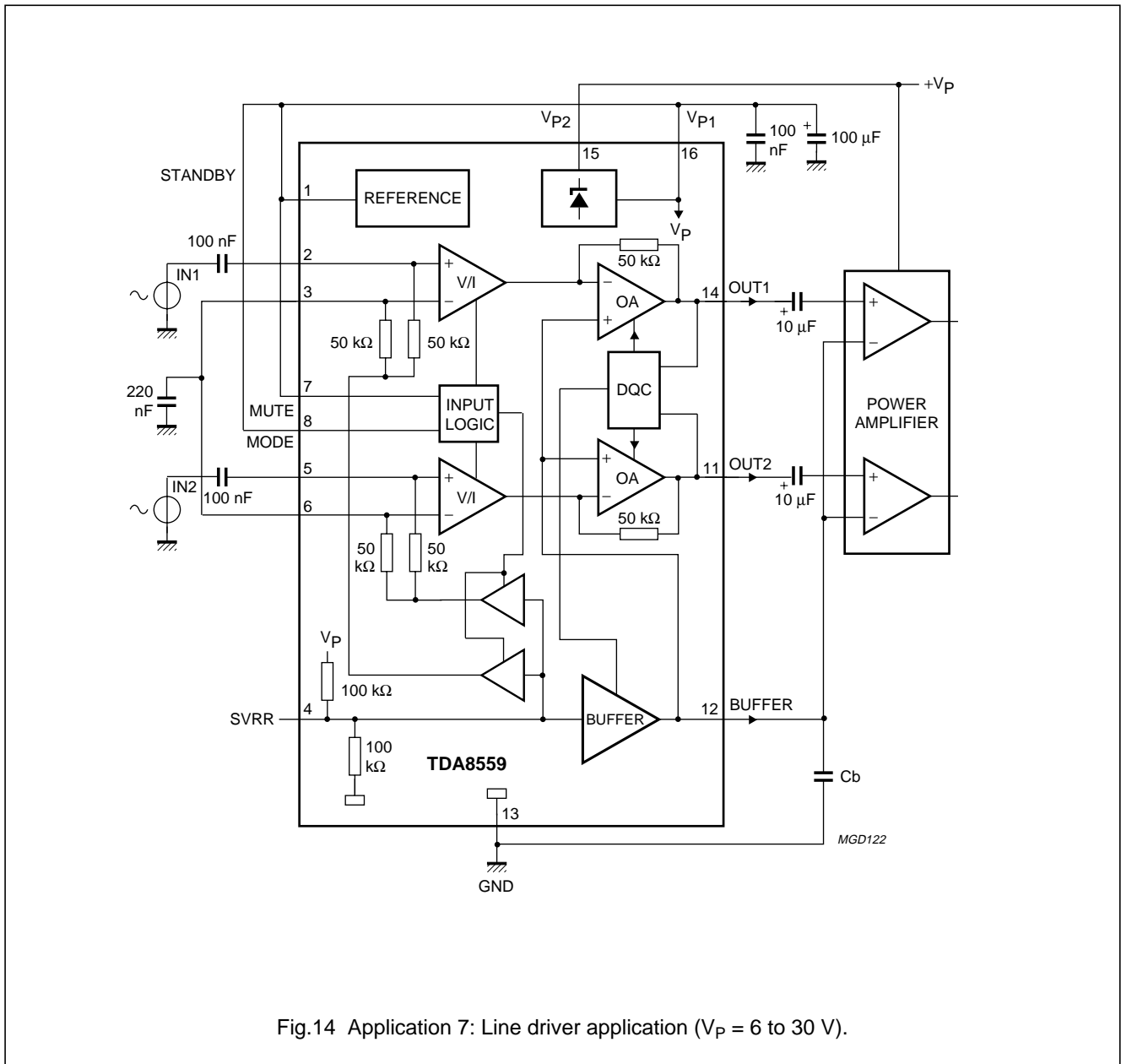

Fig.13 Application 6: Line driver application ($V_P = 6$ to 18 V).

Low-voltage stereo headphone amplifier

TDA8559



Low-voltage stereo headphone amplifier

TDA8559

Response curves for low input mode

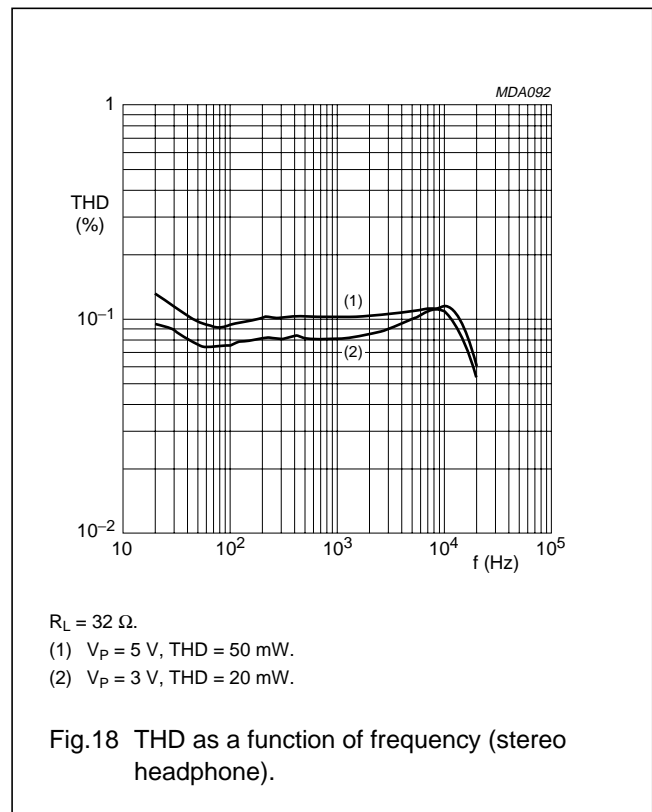
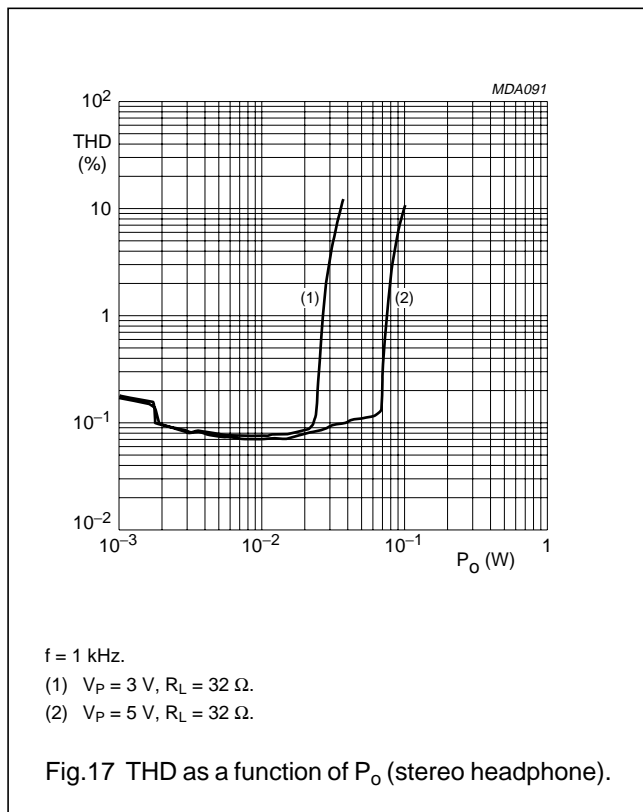
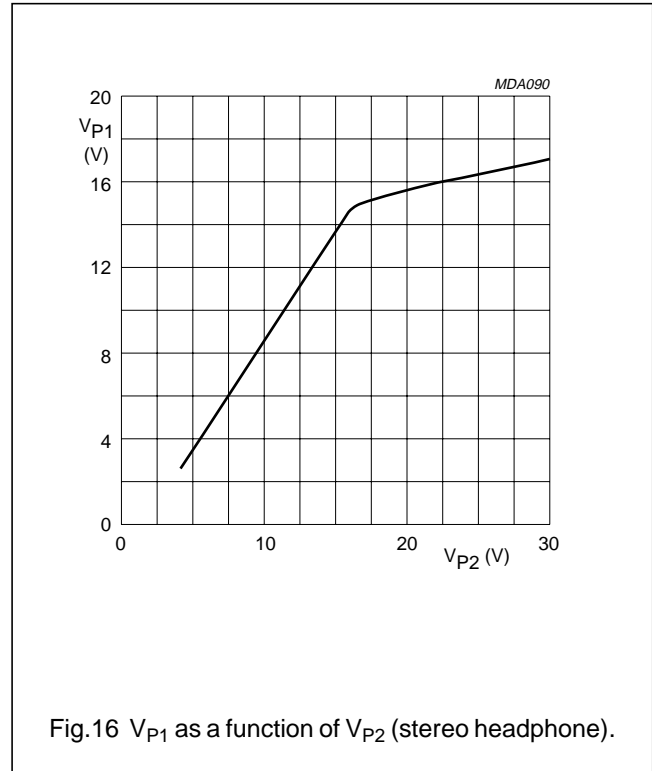
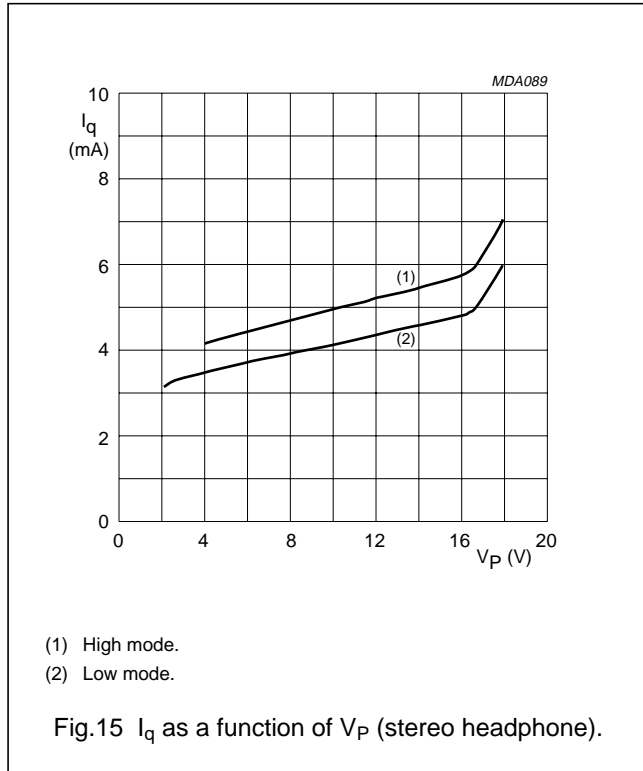

Low-voltage stereo headphone amplifier

TDA8559

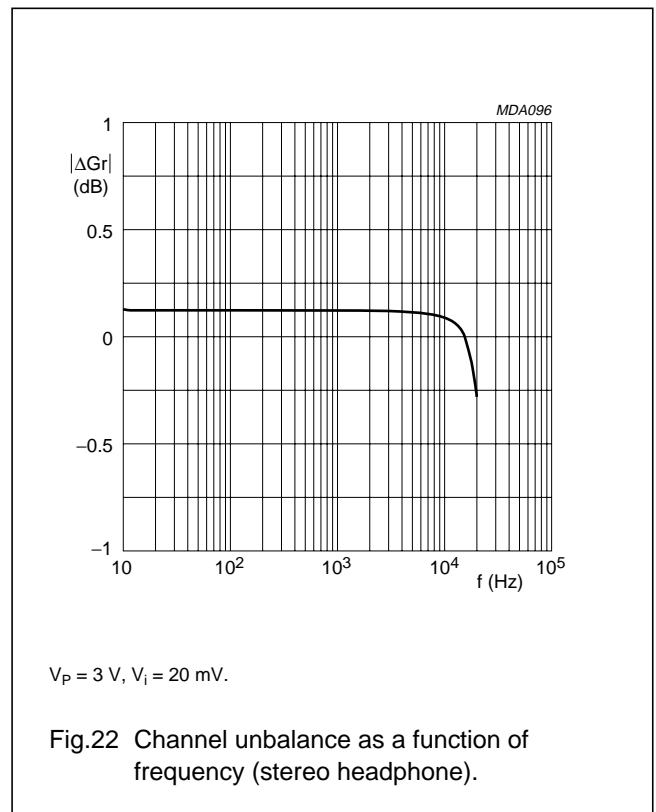
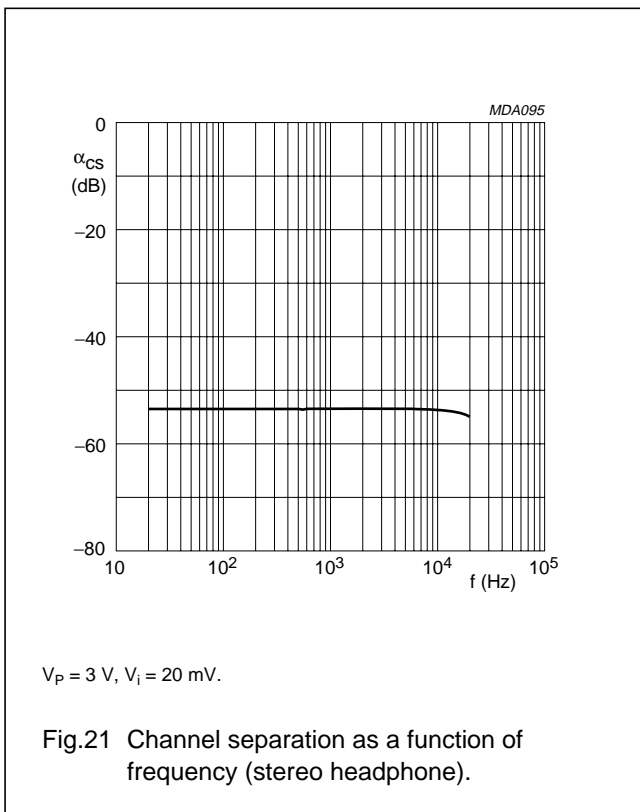
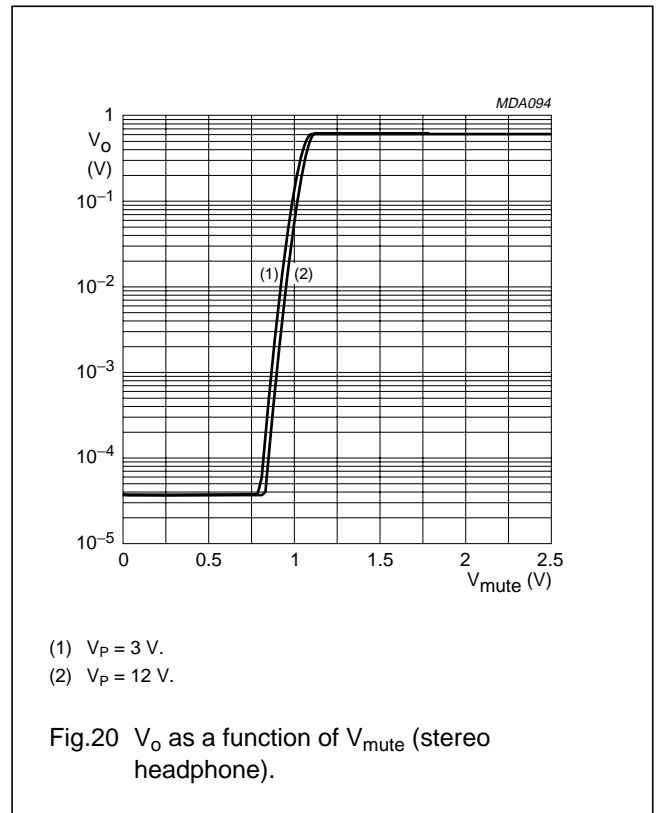
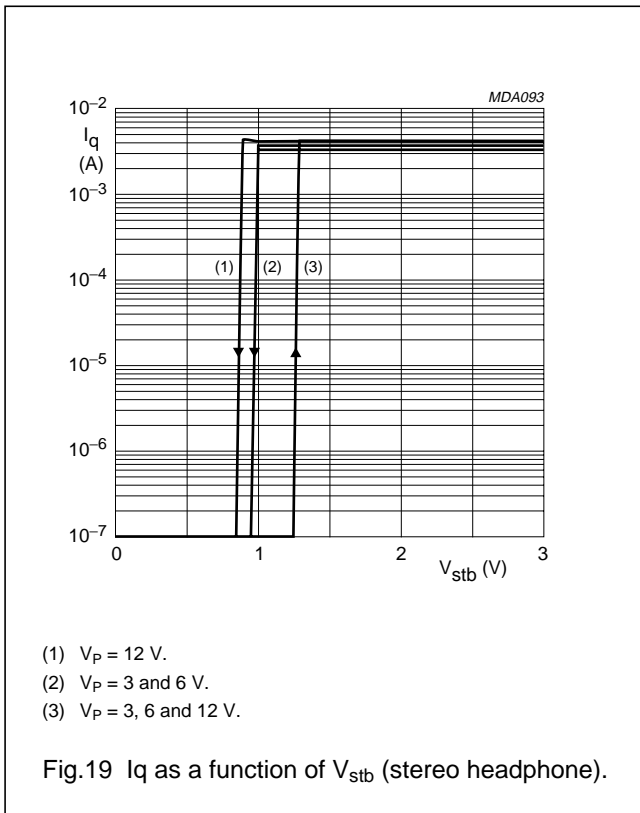

Low-voltage stereo headphone amplifier

TDA8559

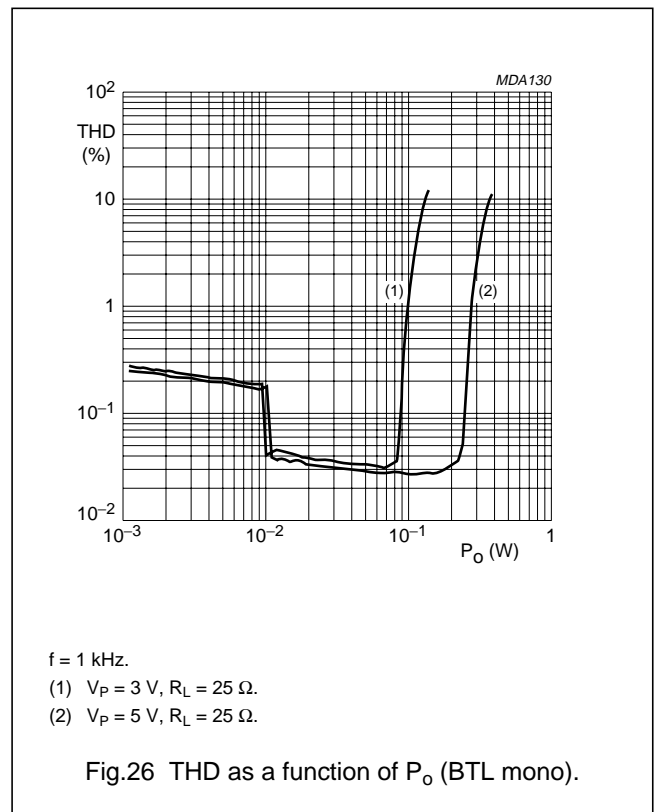
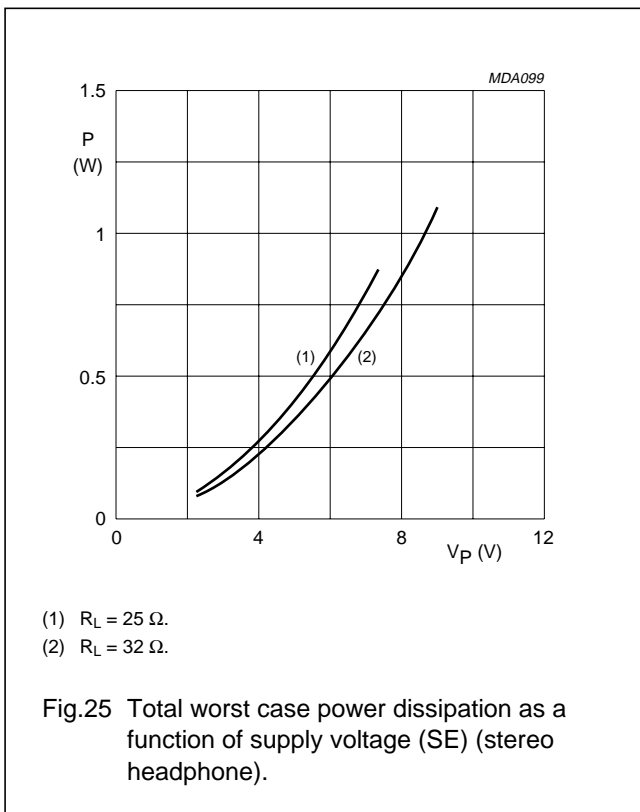
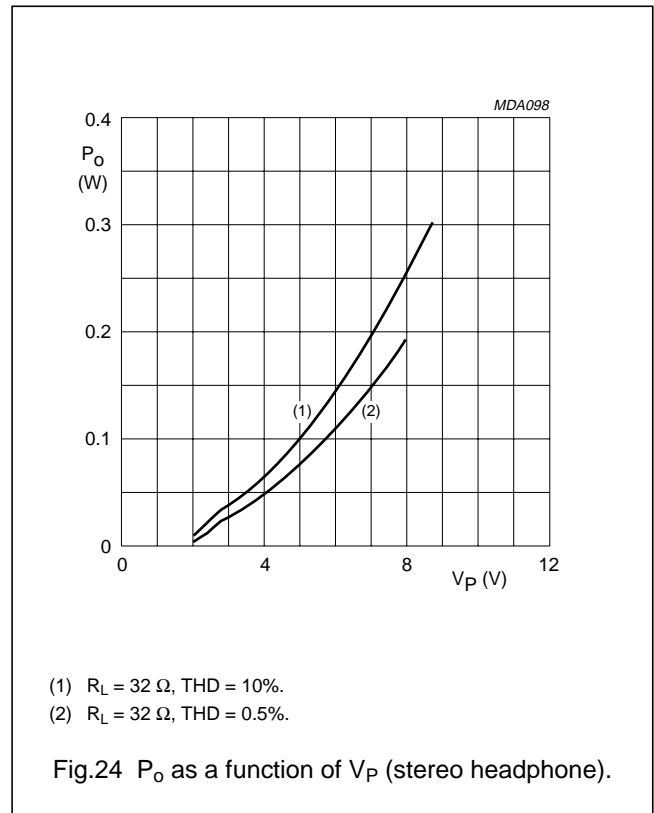
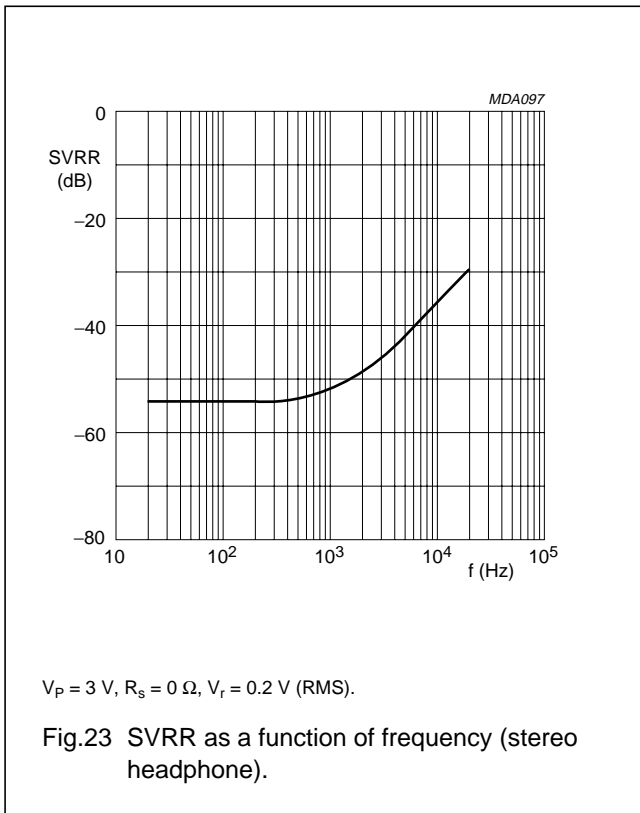

Low-voltage stereo headphone amplifier

TDA8559

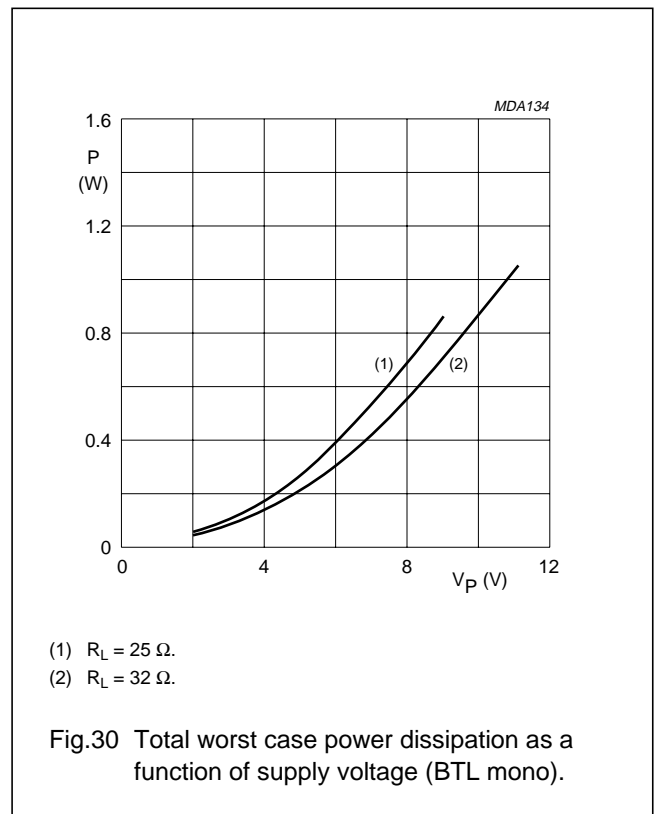
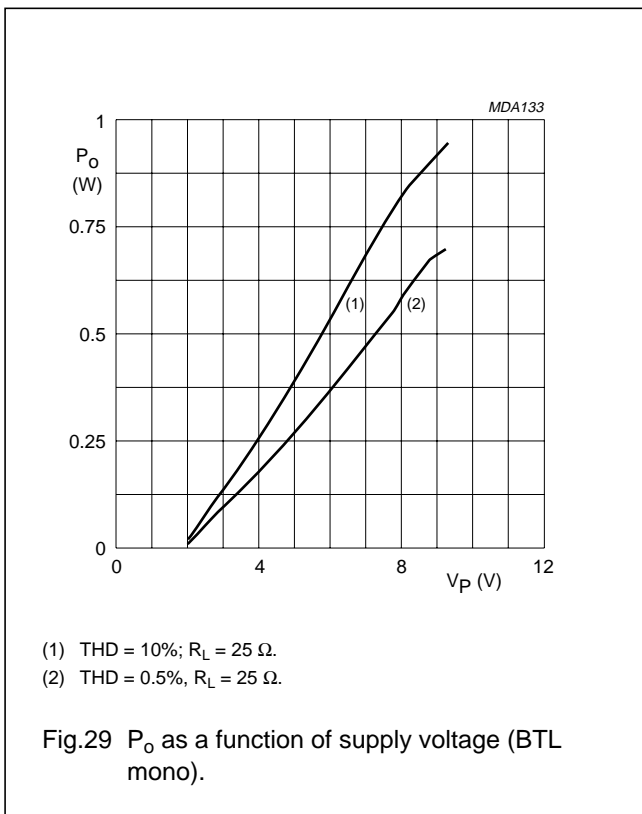
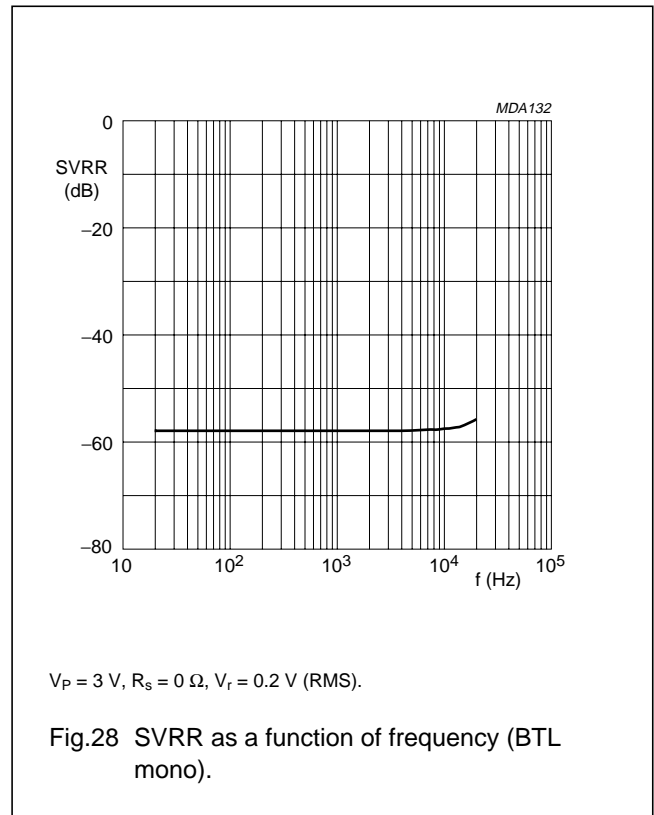
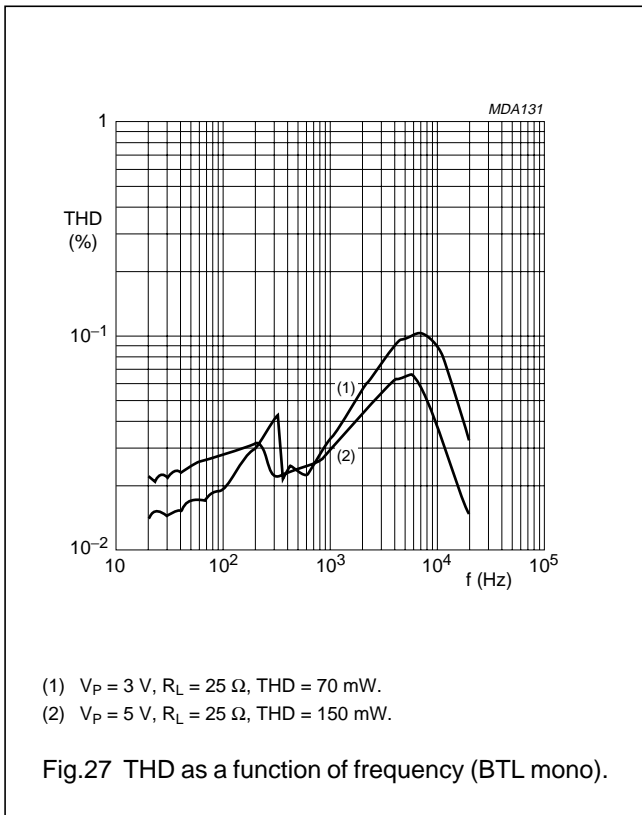

Low-voltage stereo headphone amplifier

TDA8559

Response curves for high input mode

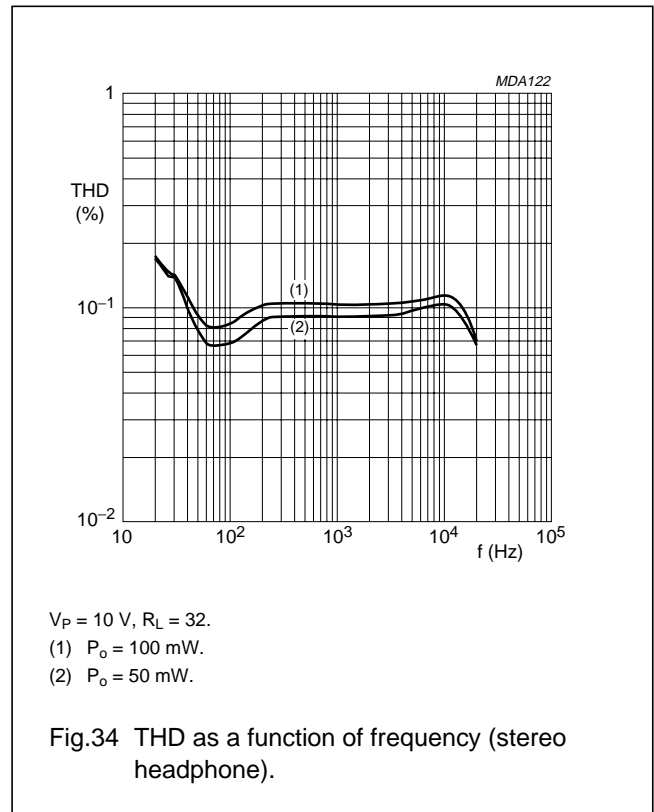
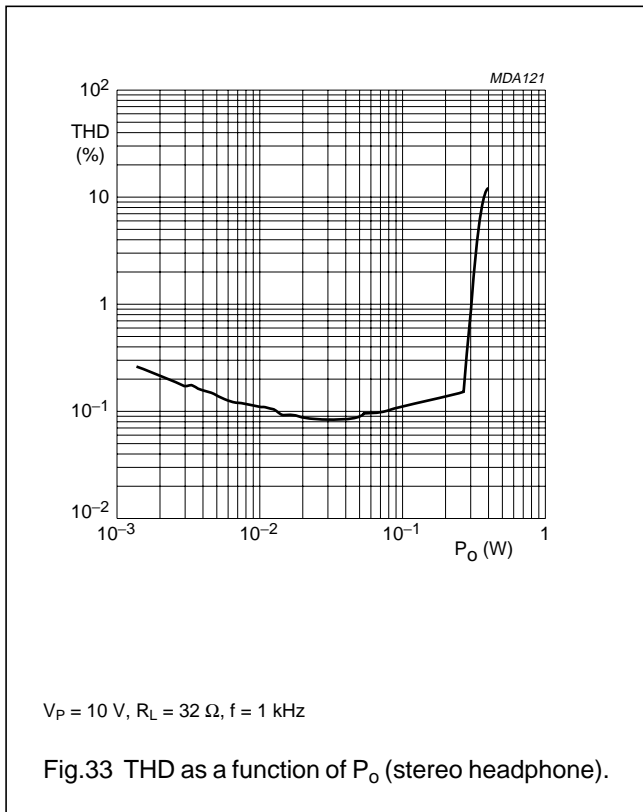
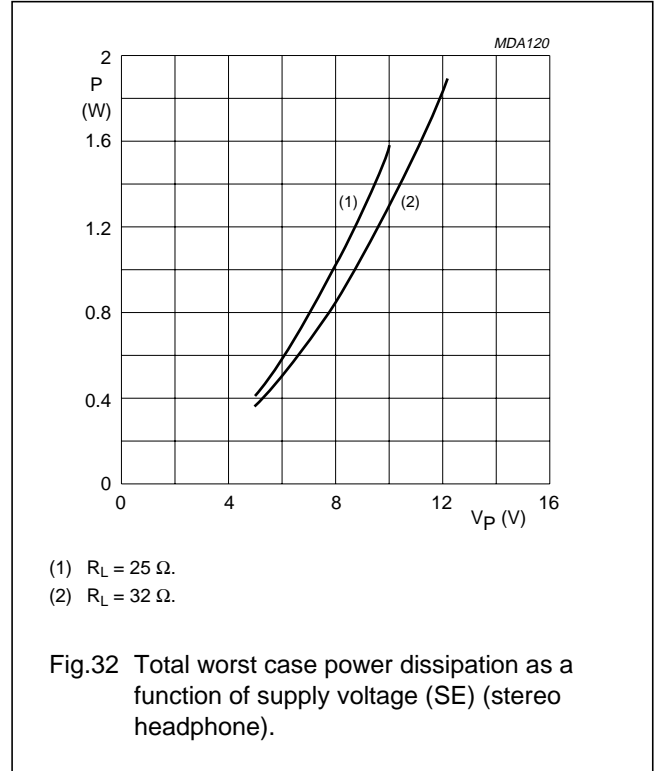
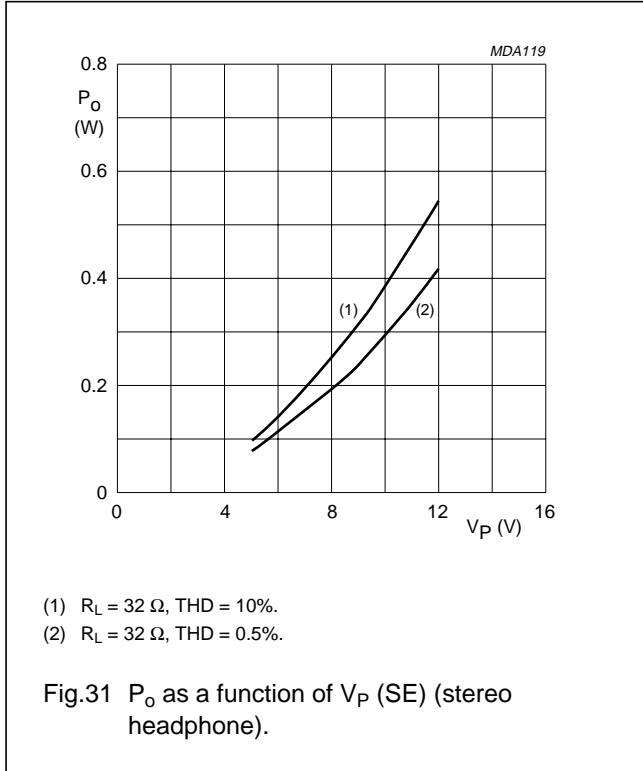

Low-voltage stereo headphone amplifier

TDA8559

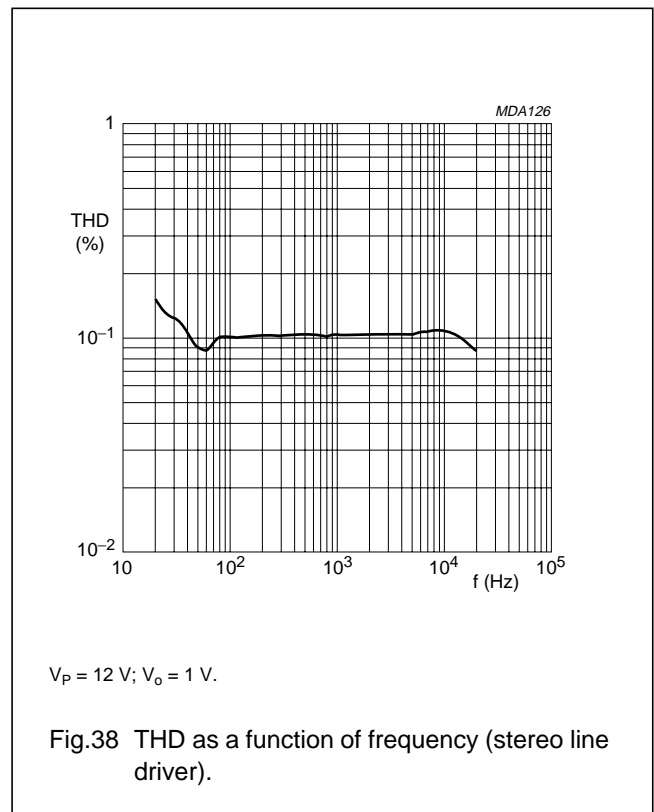
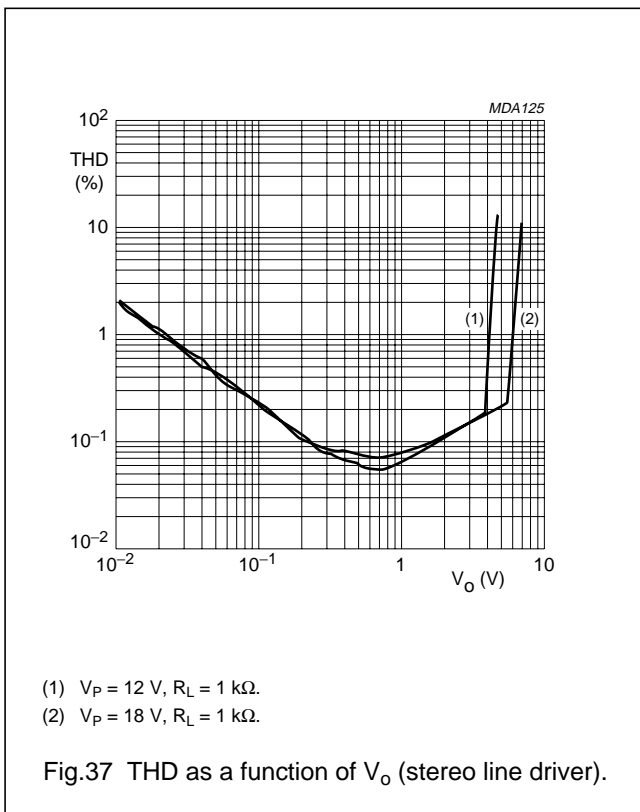
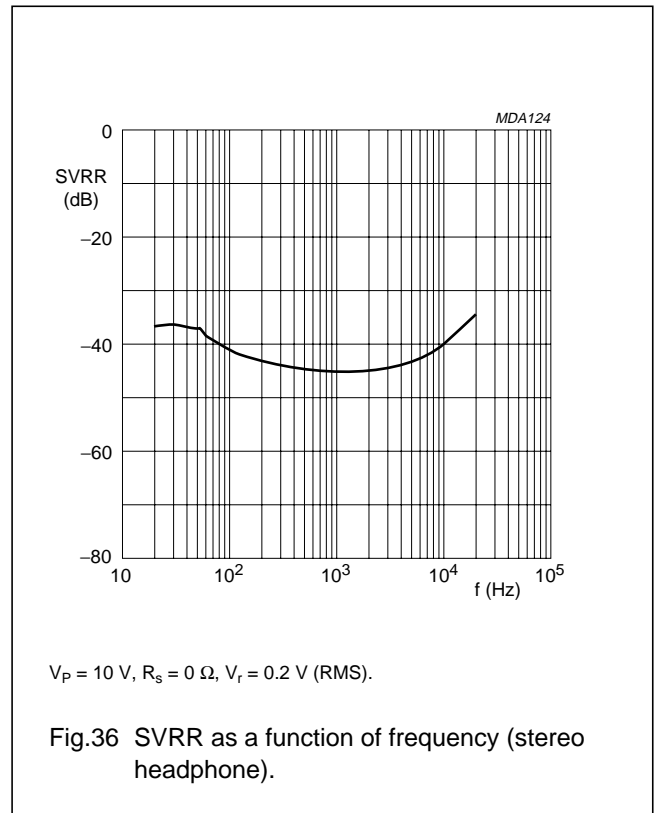
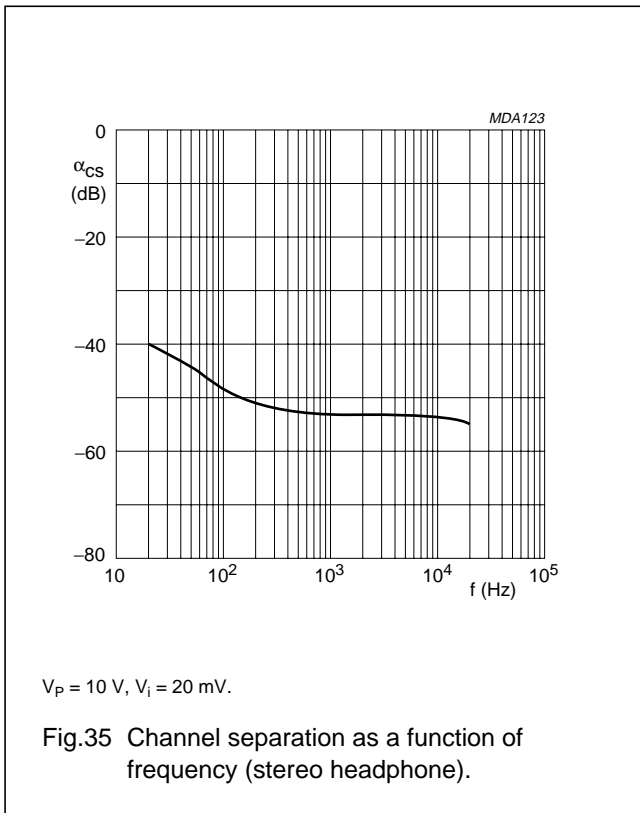

Low-voltage stereo headphone amplifier

TDA8559

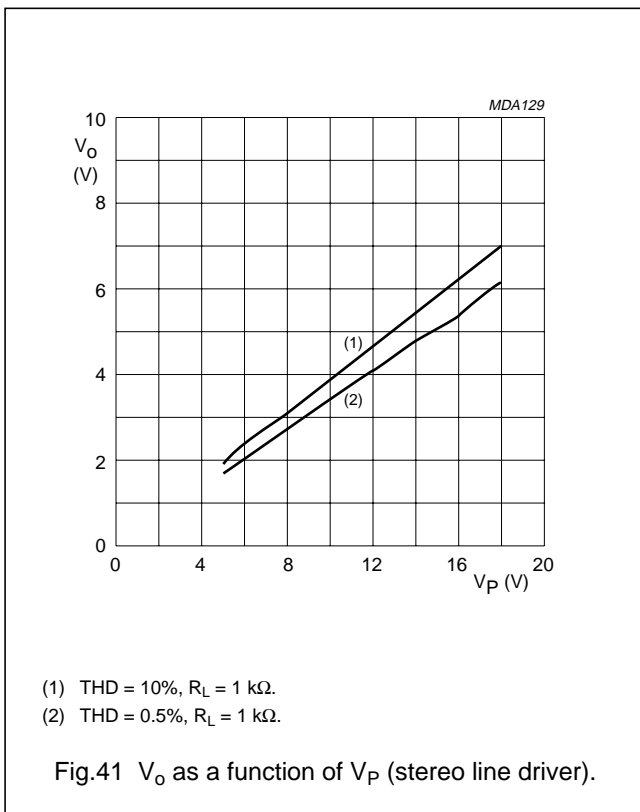
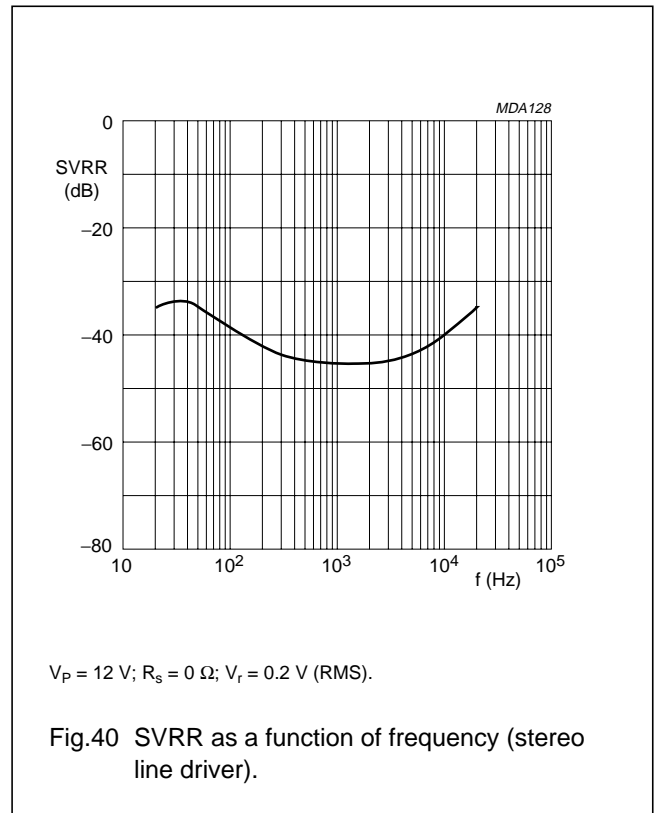
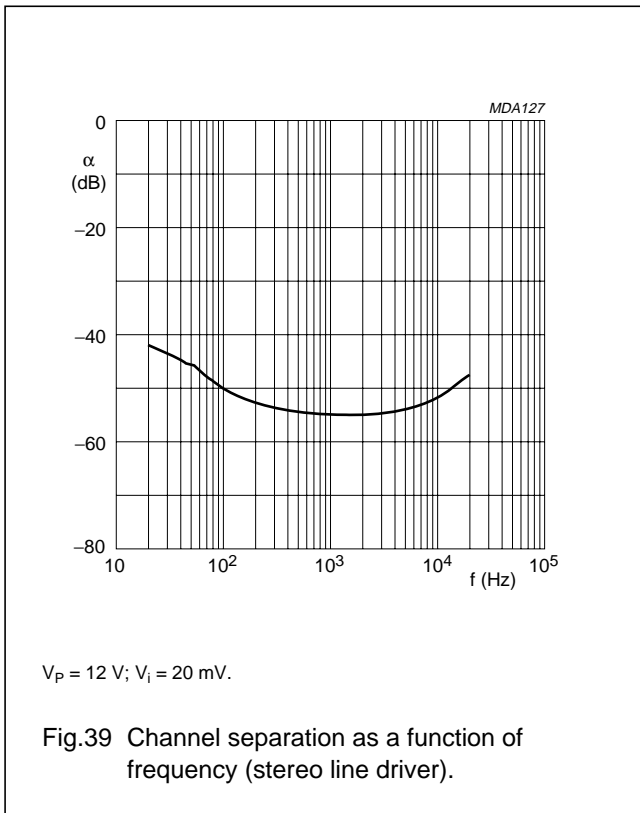

Low-voltage stereo headphone amplifier

TDA8559

INTERNAL PIN CONFIGURATION

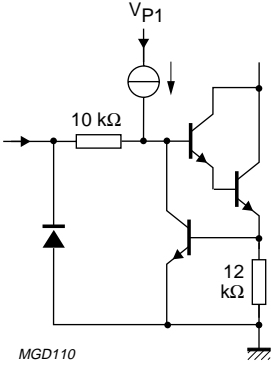
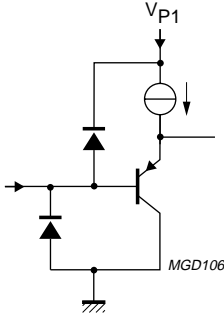
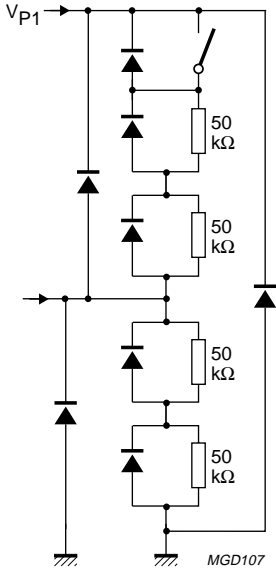
SYMBOL	PIN	EQUIVALENT CIRCUIT
STANDBY	1	
+IN1, -IN1, +IN2 and -IN2	2, 3, 5 and 6	
SVRR	4	

Low-voltage stereo headphone amplifier

TDA8559

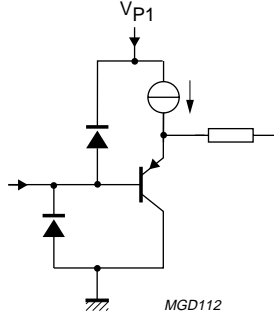
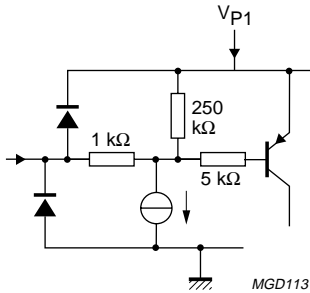
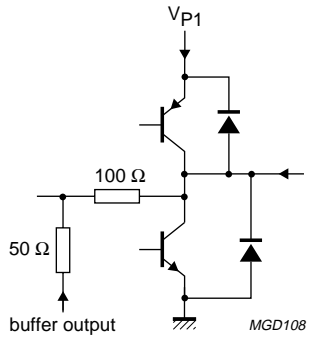
SYMBOL	PIN	EQUIVALENT CIRCUIT
MUTE	7	
INPUT MODE	8	
OUT2 and OUT1	11 and 14	

Low-voltage stereo headphone amplifier

TDA8559

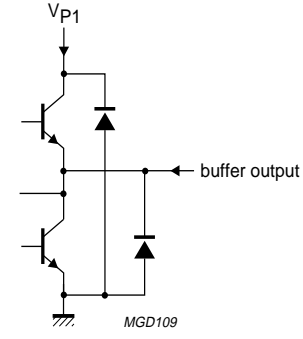
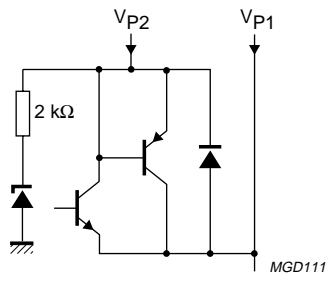
SYMBOL	PIN	EQUIVALENT CIRCUIT
BUFFER	12	
VP2 and VP1	15 and 16	

Low-voltage stereo headphone amplifier

TDA8559

PACKAGE OUTLINES

DIP16: plastic dual in-line package; 16 leads (300 mil); long body

SOT38-1

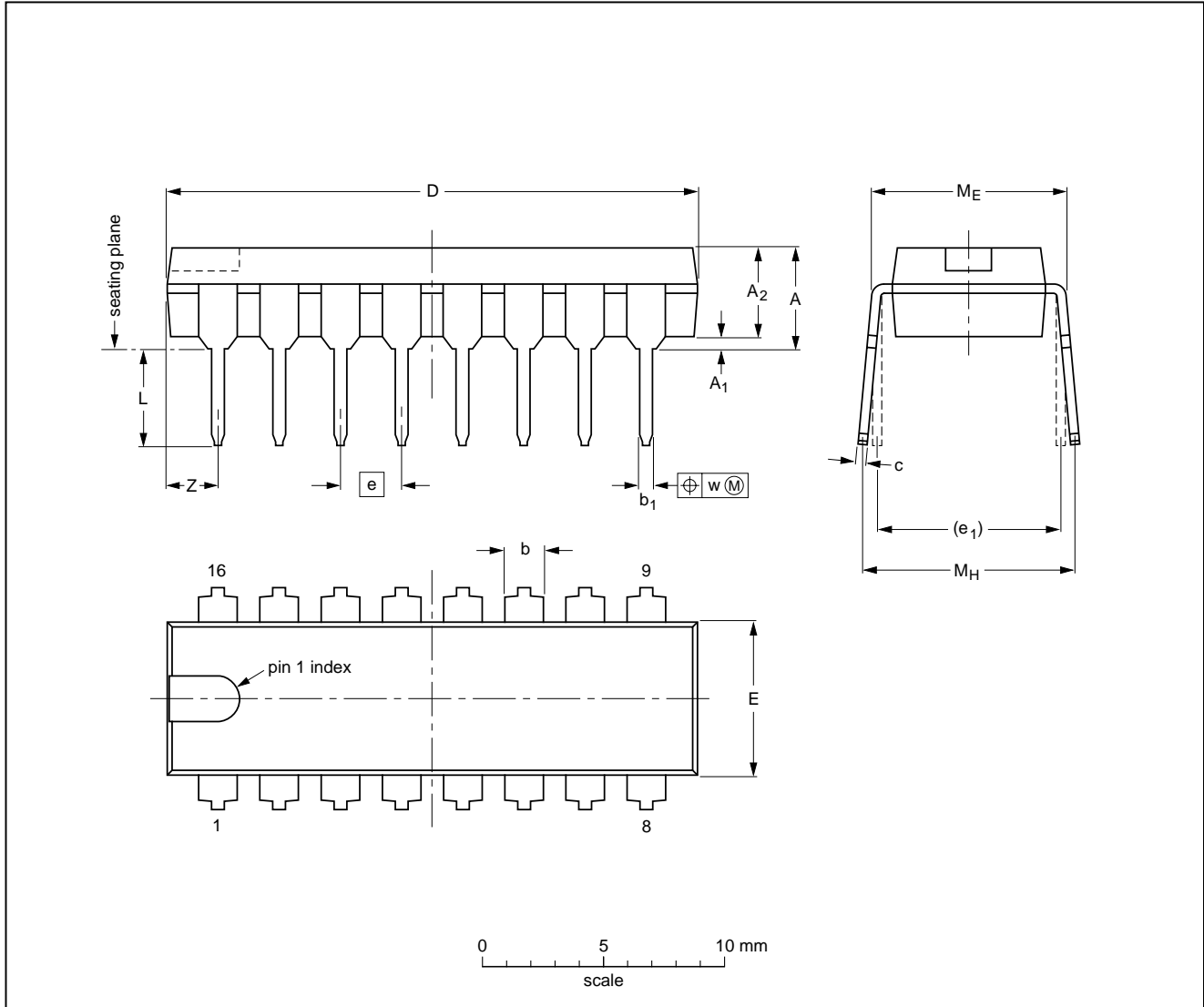

DIMENSIONS (inch dimensions are derived from the original mm dimensions)

UNIT	A max.	A ₁ min.	A ₂ max.	b	b ₁	c	D ⁽¹⁾	E ⁽¹⁾	e	e ₁	L	M _E	M _H	w	Z ⁽¹⁾ max.
mm	4.7	0.51	3.7	1.40 1.14	0.53 0.38	0.32 0.23	21.8 21.4	6.48 6.20	2.54	7.62	3.9 3.4	8.25 7.80	9.5 8.3	0.254	2.2
inches	0.19	0.020	0.15	0.055 0.045	0.021 0.015	0.013 0.009	0.86 0.84	0.26 0.24	0.10	0.30	0.15 0.13	0.32 0.31	0.37 0.33	0.01	0.087

Note

1. Plastic or metal protrusions of 0.25 mm maximum per side are not included.

OUTLINE VERSION	REFERENCES				EUROPEAN PROJECTION	ISSUE DATE
	IEC	JEDEC	EIAJ			
SOT38-1	050G09	MO-001AE				92-10-02 95-01-19

Low-voltage stereo headphone amplifier

TDA8559

SO16: plastic small outline package; 16 leads; body width 3.9 mm

SOT109-1

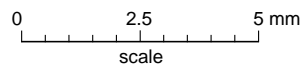
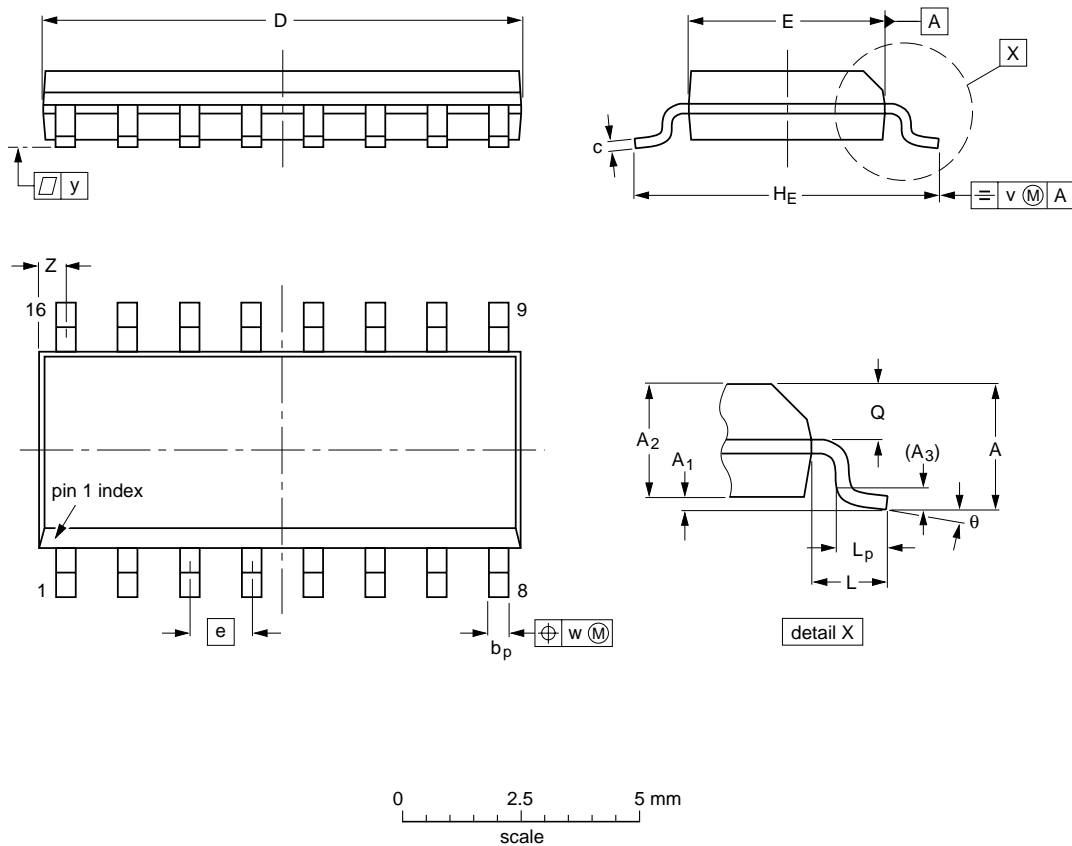

DIMENSIONS (inch dimensions are derived from the original mm dimensions)

UNIT	A max.	A ₁	A ₂	A ₃	b _p	c	D ⁽¹⁾	E ⁽¹⁾	e	H _E	L	L _p	Q	v	w	y	z ⁽¹⁾	θ
mm	1.75	0.25 0.10	1.45 1.25	0.25	0.49 0.36	0.25 0.19	10.0 9.8	4.0 3.8	1.27	6.2 5.8	1.05	1.0 0.4	0.7 0.6	0.25	0.25	0.1	0.7 0.3	8° 0°
inches	0.069	0.010 0.004	0.057 0.049	0.01	0.019 0.014	0.0100 0.0075	0.39 0.38	0.16 0.15	0.050	0.244 0.228	0.041	0.039 0.016	0.028 0.020	0.01	0.01	0.004	0.028 0.012	

Note

1. Plastic or metal protrusions of 0.15 mm maximum per side are not included.

OUTLINE VERSION	REFERENCES				EUROPEAN PROJECTION	ISSUE DATE
	IEC	JEDEC	EIAJ			
SOT109-1	076E07S	MS-012AC				95-01-23 97-05-22

Low-voltage stereo headphone amplifier

TDA8559

SOLDERING

Introduction

There is no soldering method that is ideal for all IC packages. Wave soldering is often preferred when through-hole and surface mounted components are mixed on one printed-circuit board. However, wave soldering is not always suitable for surface mounted ICs, or for printed-circuits with high population densities. In these situations reflow soldering is often used.

This text gives a very brief insight to a complex technology. A more in-depth account of soldering ICs can be found in our "IC Package Databook" (order code 9398 652 90011).

DIP

SOLDERING BY DIPPING OR BY WAVE

The maximum permissible temperature of the solder is 260 °C; solder at this temperature must not be in contact with the joint for more than 5 seconds. The total contact time of successive solder waves must not exceed 5 seconds.

The device may be mounted up to the seating plane, but the temperature of the plastic body must not exceed the specified maximum storage temperature ($T_{stg\ max}$). If the printed-circuit board has been pre-heated, forced cooling may be necessary immediately after soldering to keep the temperature within the permissible limit.

REPAIRING SOLDERED JOINTS

Apply a low voltage soldering iron (less than 24 V) to the lead(s) of the package, below the seating plane or not more than 2 mm above it. If the temperature of the soldering iron bit is less than 300 °C it may remain in contact for up to 10 seconds. If the bit temperature is between 300 and 400 °C, contact may be up to 5 seconds.

SO

REFLOW SOLDERING

Reflow soldering techniques are suitable for all SO packages.

Reflow soldering requires solder paste (a suspension of fine solder particles, flux and binding agent) to be applied to the printed-circuit board by screen printing, stencilling or pressure-syringe dispensing before package placement.

Several techniques exist for reflowing; for example, thermal conduction by heated belt. Dwell times vary between 50 and 300 seconds depending on heating method. Typical reflow temperatures range from 215 to 250 °C.

Preheating is necessary to dry the paste and evaporate the binding agent. Preheating duration: 45 minutes at 45 °C.

WAVE SOLDERING

Wave soldering techniques can be used for all SO packages if the following conditions are observed:

- A double-wave (a turbulent wave with high upward pressure followed by a smooth laminar wave) soldering technique should be used.
- The longitudinal axis of the package footprint must be parallel to the solder flow.
- The package footprint must incorporate solder thieves at the downstream end.

During placement and before soldering, the package must be fixed with a droplet of adhesive. The adhesive can be applied by screen printing, pin transfer or syringe dispensing. The package can be soldered after the adhesive is cured.

Maximum permissible solder temperature is 260 °C, and maximum duration of package immersion in solder is 10 seconds, if cooled to less than 150 °C within 6 seconds. Typical dwell time is 4 seconds at 250 °C.

A mildly-activated flux will eliminate the need for removal of corrosive residues in most applications.

REPAIRING SOLDERED JOINTS

Fix the component by first soldering two diagonally-opposite end leads. Use only a low voltage soldering iron (less than 24 V) applied to the flat part of the lead. Contact time must be limited to 10 seconds at up to 300 °C. When using a dedicated tool, all other leads can be soldered in one operation within 2 to 5 seconds between 270 and 320 °C.

 Low-voltage stereo headphone amplifier

TDA8559

DEFINITIONS

Data sheet status	
Objective specification	This data sheet contains target or goal specifications for product development.
Preliminary specification	This data sheet contains preliminary data; supplementary data may be published later.
Product specification	This data sheet contains final product specifications.
Limiting values	
Limiting values given are in accordance with the Absolute Maximum Rating System (IEC 134). Stress above one or more of the limiting values may cause permanent damage to the device. These are stress ratings only and operation of the device at these or at any other conditions above those given in the Characteristics sections of the specification is not implied. Exposure to limiting values for extended periods may affect device reliability.	
Application information	
Where application information is given, it is advisory and does not form part of the specification.	

LIFE SUPPORT APPLICATIONS

These products are not designed for use in life support appliances, devices, or systems where malfunction of these products can reasonably be expected to result in personal injury. Philips customers using or selling these products for use in such applications do so at their own risk and agree to fully indemnify Philips for any damages resulting from such improper use or sale.

Philips Semiconductors – a worldwide company

Argentina: see South America

Australia: 34 Waterloo Road, NORTH RYDE, NSW 2113,
Tel. +61 2 9805 4455, Fax. +61 2 9805 4466

Austria: Computerstr. 6, A-1101 WIEN, P.O. Box 213,
Tel. +43 1 60 101, Fax. +43 1 60 101 1210

Belarus: Hotel Minsk Business Center, Bld. 3, r. 1211, Volodarski Str. 6,
220050 MINSK, Tel. +375 172 200 733, Fax. +375 172 200 773

Belgium: see The Netherlands

Brazil: see South America

Bulgaria: Philips Bulgaria Ltd., Energoproject, 15th floor,
51 James Bourchier Blvd., 1407 SOFIA,
Tel. +359 2 689 211, Fax. +359 2 689 102

Canada: PHILIPS SEMICONDUCTORS/COMPONENTS,
Tel. +1 800 234 7381

China/Hong Kong: 501 Hong Kong Industrial Technology Centre,
72 Tat Chee Avenue, Kowloon Tong, HONG KONG,
Tel. +852 2319 7888, Fax. +852 2319 7700

Colombia: see South America

Czech Republic: see Austria

Denmark: Prags Boulevard 80, PB 1919, DK-2300 COPENHAGEN S,
Tel. +45 32 88 2636, Fax. +45 31 57 0044

Finland: Sinikalliontie 3, FIN-02630 ESPOO,
Tel. +358 9 615800, Fax. +358 9 61580920

France: 4 Rue du Port-aux-Vins, BP317, 92156 SURESNES Cedex,
Tel. +33 1 40 99 6161, Fax. +33 1 40 99 6427

Germany: Hammerbrookstraße 69, D-20097 HAMBURG,
Tel. +49 40 23 53 60, Fax. +49 40 23 536 300

Greece: No. 15, 25th March Street, GR 17778 TAVROS/ATHENS,
Tel. +30 1 4894 339/239, Fax. +30 1 4814 240

Hungary: see Austria

India: Philips INDIA Ltd, Shivsagar Estate, A Block, Dr. Annie Besant Rd.
Worli, MUMBAI 400 018, Tel. +91 22 4938 541, Fax. +91 22 4938 722

Indonesia: see Singapore

Ireland: Newstead, Clonskeagh, DUBLIN 14,
Tel. +353 1 7640 000, Fax. +353 1 7640 200

Israel: RAPAC Electronics, 7 Kehilat Saloniki St, PO Box 18053,
TEL AVIV 61180, Tel. +972 3 645 0444, Fax. +972 3 649 1007

Italy: PHILIPS SEMICONDUCTORS, Piazza IV Novembre 3,
20124 MILANO, Tel. +39 2 6752 2531, Fax. +39 2 6752 2557

Japan: Philips Bldg 13-37, Kohnan 2-chome, Minato-ku, TOKYO 108,
Tel. +81 3 3740 5130, Fax. +81 3 3740 5077

Korea: Philips House, 260-199 Itaewon-dong, Yongsan-ku, SEOUL,
Tel. +82 2 709 1412, Fax. +82 2 709 1415

Malaysia: No. 76 Jalan Universiti, 46200 PETALING JAYA, SELANGOR,
Tel. +60 3 750 5214, Fax. +60 3 757 4880

Mexico: 5900 Gateway East, Suite 200, EL PASO, TEXAS 79905,
Tel. +9-5 800 234 7381

Middle East: see Italy

Netherlands: Postbus 90050, 5600 PB EINDHOVEN, Bldg. VB,
Tel. +31 40 27 82785, Fax. +31 40 27 88399

New Zealand: 2 Wagener Place, C.P.O. Box 1041, AUCKLAND,
Tel. +64 9 849 4160, Fax. +64 9 849 7811

Norway: Box 1, Manglerud 0612, OSLO,
Tel. +47 22 74 8000, Fax. +47 22 74 8341

Philippines: Philips Semiconductors Philippines Inc.,
106 Valero St. Salcedo Village, P.O. Box 2108 MCC, MAKATI,
Metro MANILA, Tel. +63 2 816 6380, Fax. +63 2 817 3474

Poland: Ul. Lukiska 10, PL 04-123 WARSZAWA,
Tel. +48 22 612 2831, Fax. +48 22 612 2327

Portugal: see Spain

Romania: see Italy

Russia: Philips Russia, Ul. Usatcheva 35A, 119048 MOSCOW,
Tel. +7 095 755 6918, Fax. +7 095 755 6919

Singapore: Lorong 1, Toa Payoh, SINGAPORE 1231,
Tel. +65 350 2538, Fax. +65 251 6500

Slovakia: see Austria

Slovenia: see Italy

South Africa: S.A. PHILIPS Pty Ltd., 195-215 Main Road Martindale,
2092 JOHANNESBURG, P.O. Box 7430 Johannesburg 2000,
Tel. +27 11 470 5911, Fax. +27 11 470 5494

South America: Rua do Rocio 220, 5th floor, Suite 51,
04552-903 São Paulo, SÃO PAULO - SP, Brazil,
Tel. +55 11 821 2333, Fax. +55 11 829 1849

Spain: Balmes 22, 08007 BARCELONA,
Tel. +34 3 301 6312, Fax. +34 3 301 4107

Sweden: Kottbygatan 7, Akalla, S-16485 STOCKHOLM,
Tel. +46 8 632 2000, Fax. +46 8 632 2745

Switzerland: Allmendstrasse 140, CH-8027 ZÜRICH,
Tel. +41 1 488 2686, Fax. +41 1 481 7730

Taiwan: Philips Semiconductors, 6F, No. 96, Chien Kuo N. Rd., Sec. 1,
TAIPEI, Taiwan Tel. +886 2 2134 2865, Fax. +886 2 2134 2874

Thailand: PHILIPS ELECTRONICS (THAILAND) Ltd.,
209/2 Sanpavuth-Bangna Road Prakanong, BANGKOK 10260,
Tel. +66 2 745 4090, Fax. +66 2 398 0793

Turkey: Talatpasa Cad. No. 5, 80640 GÜLTEPE/ISTANBUL,
Tel. +90 212 279 2770, Fax. +90 212 282 6707

Ukraine: PHILIPS UKRAINE, 4 Patrice Lumumba str., Building B, Floor 7,
252042 KIEV, Tel. +380 44 264 2776, Fax. +380 44 268 0461

United Kingdom: Philips Semiconductors Ltd., 276 Bath Road, Hayes,
MIDDLESEX UB3 5BX, Tel. +44 181 730 5000, Fax. +44 181 754 8421

United States: 811 East Arques Avenue, SUNNYVALE, CA 94088-3409,
Tel. +1 800 234 7381

Uruguay: see South America

Vietnam: see Singapore

Yugoslavia: PHILIPS, Trg N. Pasica 5/v, 11000 BEOGRAD,
Tel. +381 11 625 344, Fax. +381 11 635 777

For all other countries apply to: Philips Semiconductors, Marketing & Sales Communications,
Building BE-p, P.O. Box 218, 5600 MD EINDHOVEN, The Netherlands, Fax. +31 40 27 24825

Internet: <http://www.semiconductors.philips.com>

© Philips Electronics N.V. 1997

SCA54

All rights are reserved. Reproduction in whole or in part is prohibited without the prior written consent of the copyright owner.

The information presented in this document does not form part of any quotation or contract, is believed to be accurate and reliable and may be changed without notice. No liability will be accepted by the publisher for any consequence of its use. Publication thereof does not convey nor imply any license under patent- or other industrial or intellectual property rights.

Printed in The Netherlands

547027/1200/02/pp32

Date of release: 1997 Jun 27

Document order number: 9397 750 02066

Let's make things better.

Philips
Semiconductors



PHILIPS