

DATA SHEET

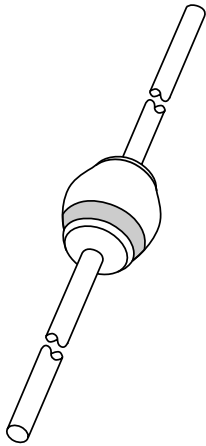

BY228 Damper diode

Product specification
Supersedes data of May 1996

1996 Sep 26

Damper diode

BY228

FEATURES

- Glass passivated
- High maximum operating temperature
- Low leakage current
- Excellent stability
- Available in ammo-pack
- Also available with preformed leads for easy insertion.

APPLICATIONS

- Damper diode in high frequency horizontal deflection circuits up to 16 kHz.

DESCRIPTION

Rugged glass package, using a high temperature alloyed construction.

This package is hermetically sealed and fatigue free as coefficients of expansion of all used parts are matched.

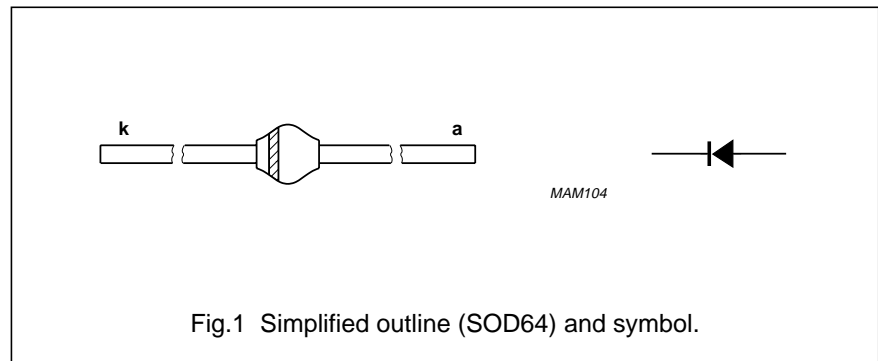

LIMITING VALUES

In accordance with the Absolute Maximum Rating System (IEC 134).

SYMBOL	PARAMETER	CONDITIONS	MIN.	MAX.	UNIT
V_{RSM}	non-repetitive peak reverse voltage		–	1650	V
V_{RRM}	repetitive peak reverse voltage		–	1650	V
V_R	continuous reverse voltage		–	1500	V
I_{FWM}	working peak forward current	$T_{amb} = 75\text{ °C}$; PCB mounting (see Fig.4); see Fig.2	–	5	A
I_{FRM}	repetitive peak forward current		–	10	A
I_{FSM}	non-repetitive peak forward current	$t = 10\text{ ms}$ half sinewave; $T_j = T_{j\text{ max}}$ prior to surge; $V_R = V_{RRM\text{ max}}$	–	50	A
T_{stg}	storage temperature		–65	+175	°C
T_j	junction temperature		–65	+150	°C

ELECTRICAL CHARACTERISTICS

$T_j = 25\text{ °C}$; unless otherwise specified.

SYMBOL	PARAMETER	CONDITIONS	MAX.	UNIT
V_F	forward voltage	$I_F = 5\text{ A}$; $T_j = T_{j\text{ max}}$; see Fig.3	1.4	V
		$I_F = 5\text{ A}$; see Fig.3	1.5	V
I_R	reverse current	$V_R = V_{R\text{ max}}$; $T_j = 150\text{ °C}$	150	μA
t_{rr}	reverse recovery time	when switched from $I_F = 0.5\text{ A}$ to $I_R = 1\text{ A}$; measured at $I_R = 0.25\text{ A}$; see Fig.6	1	μs
t_{fr}	forward recovery time	when switched to $I_F = 5\text{ A}$ in 50 ns; $T_j = T_{j\text{ max}}$; Fig.7	1	μs

Damper diode

BY228

THERMAL CHARACTERISTICS

SYMBOL	PARAMETER	CONDITIONS	VALUE	UNIT
$R_{th\ j-tp}$	thermal resistance from junction to tie-point	lead length = 10 mm	25	K/W
$R_{th\ j-a}$	thermal resistance from junction to ambient	note 1	75	K/W
		mounted as shown in Fig.5	40	K/W

Note

1. Device mounted on an epoxy-glass printed-circuit board, 1.5 mm thick; thickness of Cu-layer $\geq 40\ \mu\text{m}$, see Fig.4. For more information please refer to the "General Part of associated Handbook".

Damper diode

BY228

GRAPHICAL DATA

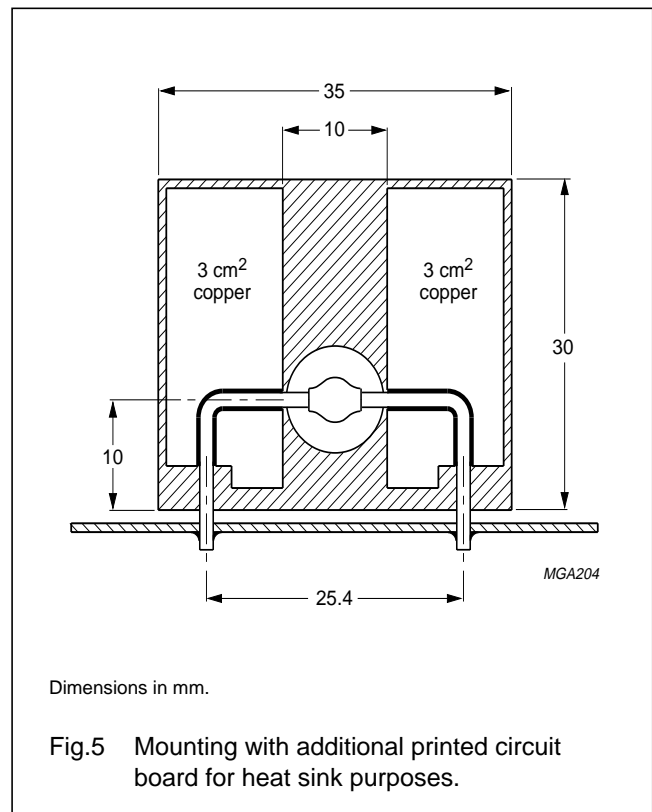
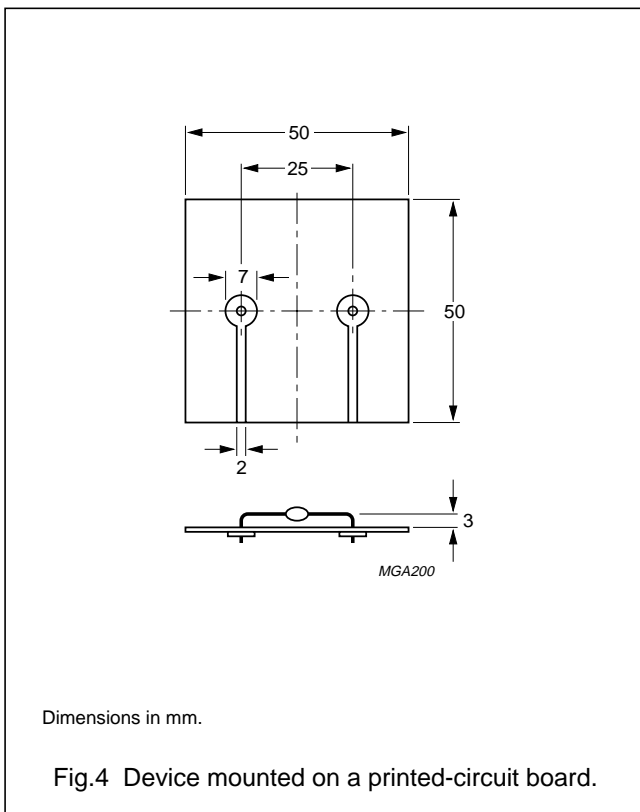
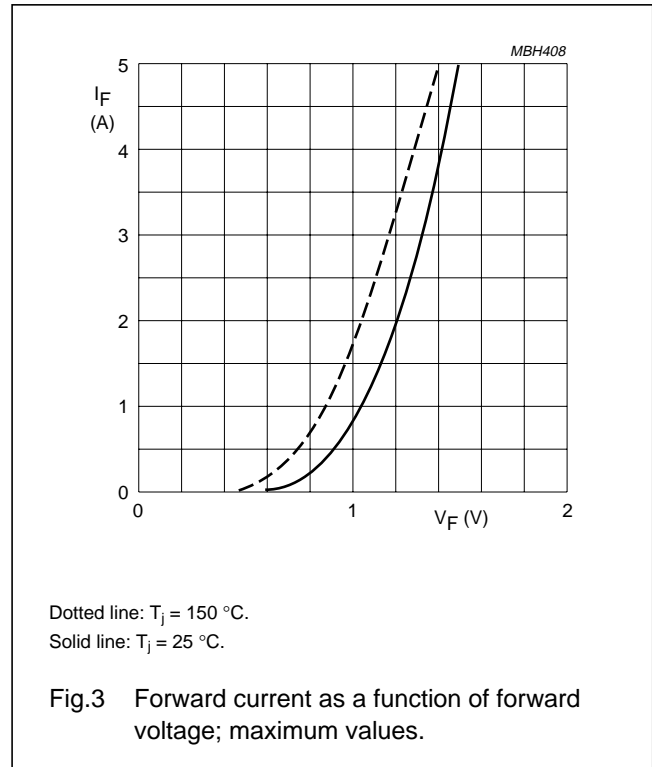
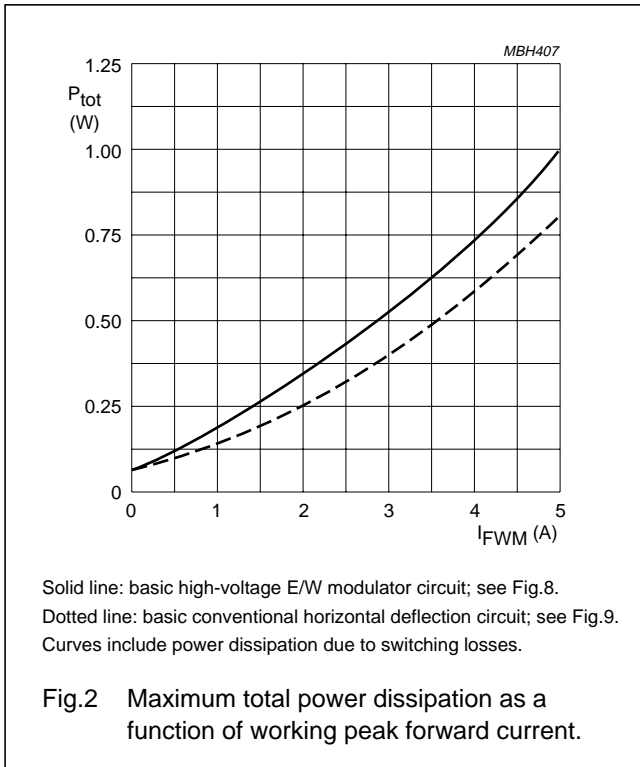

Damper diode

BY228

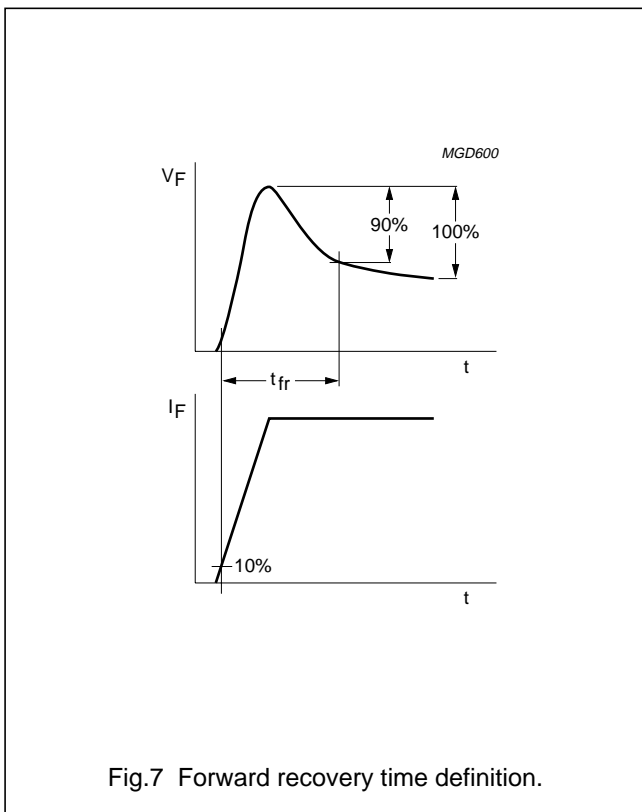
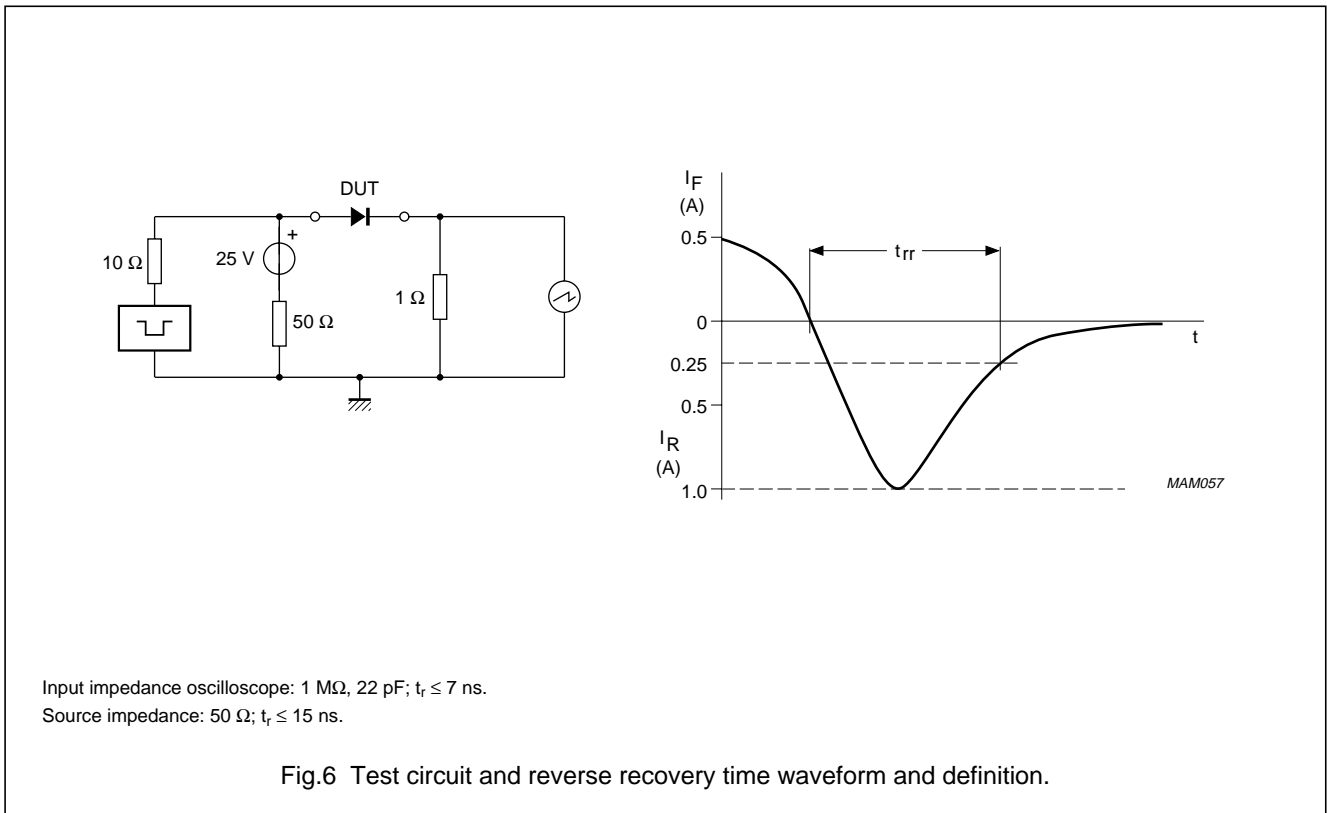

Damper diode

BY228

APPLICATION INFORMATION

For horizontal deflection circuits, two basic applications are shown in Figs 8 and 9.

The maximum allowable total power dissipation for the diode can be calculated from the thermal resistance $R_{th\ j-a}$ and the difference between $T_{j\ max}$ and $T_{amb\ max}$ in the application. The maximum I_{FWM} can then be taken from Fig.2.

The basic application waveforms in Fig.10 relate to the circuit in Fig.8. In the circuit in Fig.9 the forward conduction time of the diode is shorter, allowing a higher I_{FWM} (see Fig.2).

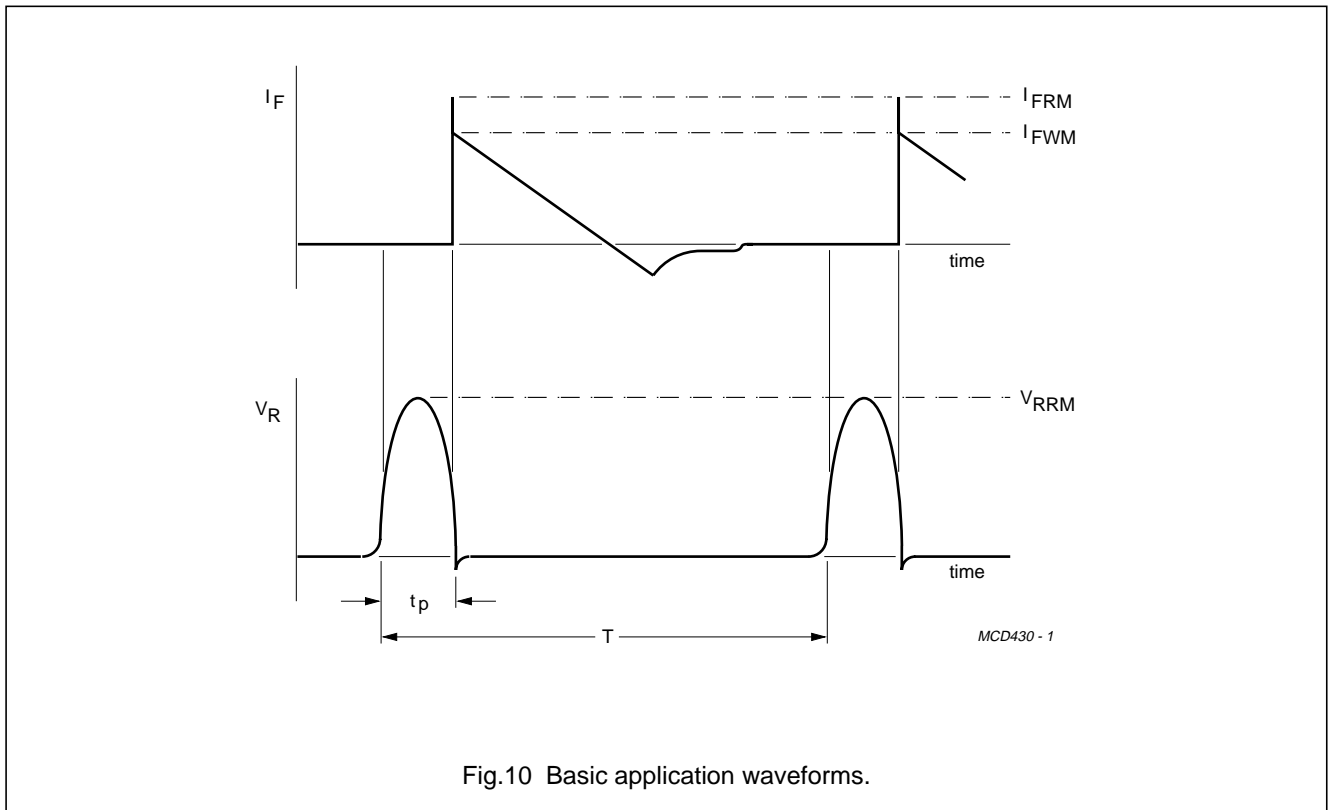
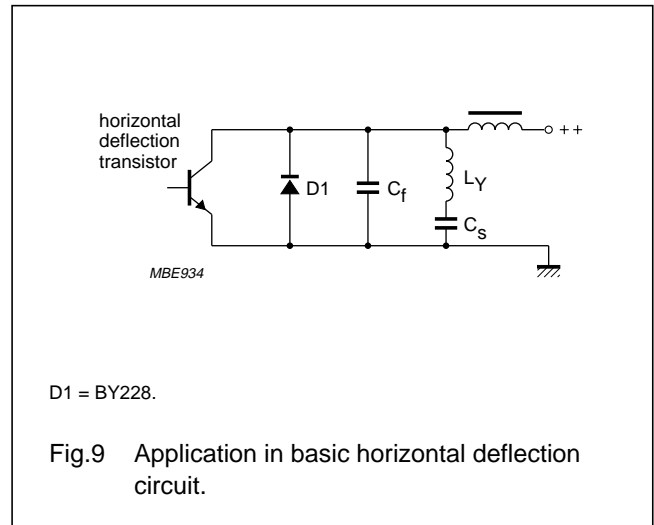
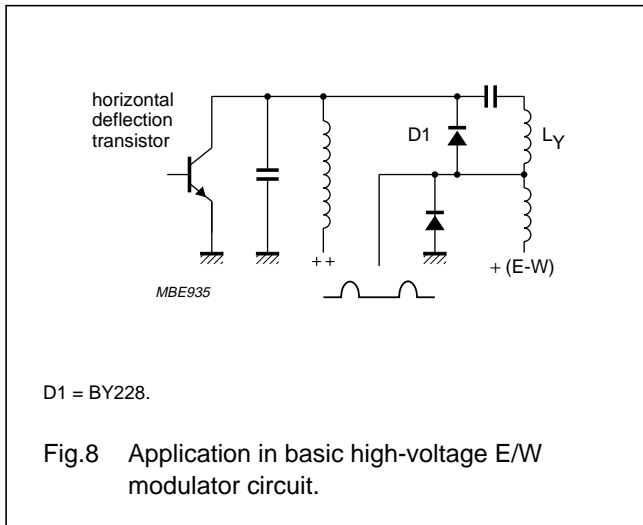

Damper diode

BY228

PACKAGE OUTLINE

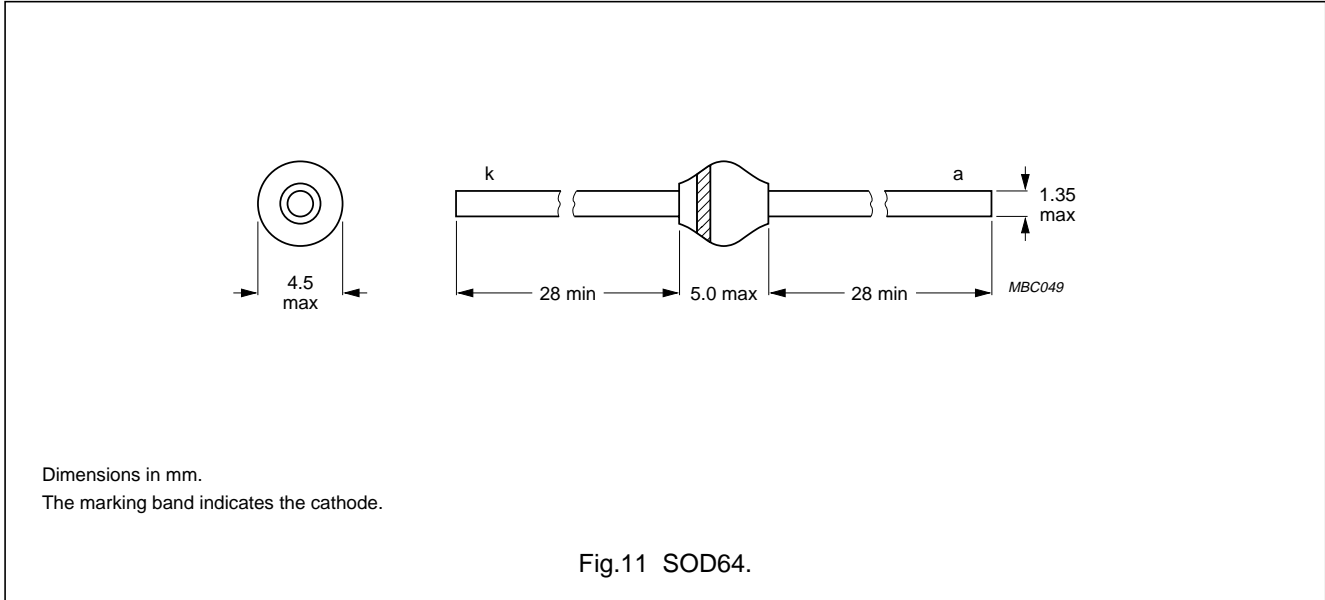

DEFINITIONS

Data Sheet Status	
Objective specification	This data sheet contains target or goal specifications for product development.
Preliminary specification	This data sheet contains preliminary data; supplementary data may be published later.
Product specification	This data sheet contains final product specifications.
Limiting values	
Limiting values given are in accordance with the Absolute Maximum Rating System (IEC 134). Stress above one or more of the limiting values may cause permanent damage to the device. These are stress ratings only and operation of the device at these or at any other conditions above those given in the Characteristics sections of the specification is not implied. Exposure to limiting values for extended periods may affect device reliability.	
Application information	
Where application information is given, it is advisory and does not form part of the specification.	

LIFE SUPPORT APPLICATIONS

These products are not designed for use in life support appliances, devices, or systems where malfunction of these products can reasonably be expected to result in personal injury. Philips customers using or selling these products for use in such applications do so at their own risk and agree to fully indemnify Philips for any damages resulting from such improper use or sale.