

DATA SHEET

TDA8714 8-bit high-speed analog-to-digital converter

Product specification
Supersedes data of 1996 Jan 31
File under Integrated Circuits, IC02

1997 Oct 29

8-bit high-speed analog-to-digital converter

TDA8714

FEATURES

- 8-bit resolution
- Sampling rate up to 80 MHz
- No missing codes guaranteed
- High signal-to-noise ratio over a large analog input frequency range (7.7 effective bits at 4.43 MHz full-scale input at $f_{\text{clk}} = 80$ MHz)
- Overflow/underflow 3-state TTL output
- TTL compatible digital inputs
- Low-level AC clock input signal allowed
- External reference voltage regulator
- Power dissipation only 340 mW (typical)
- Low analog input capacitance, no buffer amplifier required
- No sample-and-hold circuit required.

APPLICATIONS

High-speed analog-to-digital conversion for:

- video data digitizing
- radar pulse analysis
- transient signal analysis
- high energy physics research
- $\Sigma\Delta$ modulators
- medical imaging.

GENERAL DESCRIPTION

The TDA8714 is an 8-bit high-speed Analog-to-Digital Converter (ADC) for professional video and other applications. It converts the analog input signal into 8-bit binary-coded digital words at a maximum sampling rate of 80 MHz. All digital inputs and outputs are TTL compatible, although a low-level sine wave clock input signal is allowed.

QUICK REFERENCE DATA

SYMBOL	PARAMETER	CONDITIONS	MIN.	TYP.	MAX.	UNIT
V_{CCA}	analog supply voltage		4.75	5.0	5.25	V
V_{CCD}	digital supply voltage		4.75	5.0	5.25	V
V_{CCO}	output stages supply voltage		4.75	5.0	5.25	V
I_{CCA}	analog supply current		–	25	30	mA
I_{CCD}	digital supply current		–	27	33	mA
I_{CCO}	output stages supply current		–	16	20	mA
INL	DC integral non-linearity		–	± 0.4	± 0.5	LSB
DNL	DC differential non-linearity		–	± 0.2	± 0.35	LSB
AINL	AC integral non-linearity	note 1	–	± 0.5	± 1.0	LSB
$f_{\text{clk(max)}}$	maximum clock frequency					
	TDA8714/7		80	–	–	MHz
	TDA8714/6		60	–	–	MHz
	TDA8714/4		40	–	–	MHz
P_{tot}	total power dissipation		–	340	435	mW

Note

1. Full-scale sine wave ($f_i = 4.43$ MHz; $f_{\text{clk}} = 80$ MHz).

8-bit high-speed analog-to-digital converter

TDA8714

ORDERING INFORMATION

TYPE NUMBER	PACKAGE			SAMPLING FREQUENCY (MHz)
	NAME	DESCRIPTION	VERSION	
TDA8714T/4	SO24	plastic small outline package; 24 leads; body width 7.5 mm	SOT137-1	40
TDA8714T/6	SO24		SOT137-1	60
TDA8714T/7	SO24		SOT137-1	80
TDA8714M/4	SSOP24	plastic shrink small outline package; 24 leads; body width 5.3 mm	SOT340-1	40
TDA8714M/6	SSOP24		SOT340-1	60
TDA8714M/7	SSOP24		SOT340-1	80

BLOCK DIAGRAM

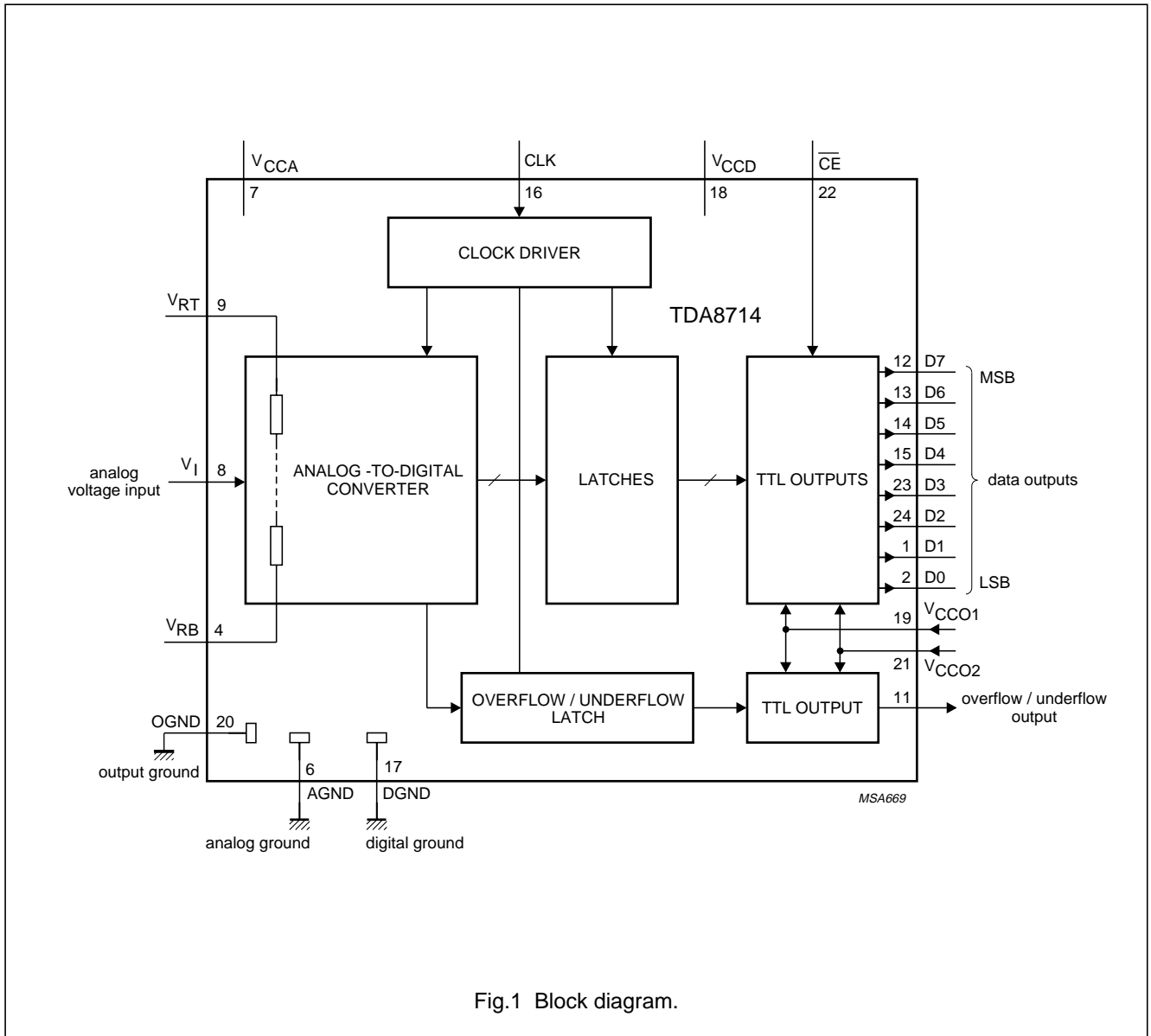

Fig.1 Block diagram.

8-bit high-speed analog-to-digital converter

TDA8714

PINNING

SYMBOL	PIN	DESCRIPTION
D1	1	data output; bit 1
D0	2	data output; bit 0 (LSB)
n.c.	3	not connected
V _{RB}	4	reference voltage BOTTOM input
n.c.	5	not connected
AGND	6	analog ground
V _{CCA}	7	analog supply voltage (+5 V)
V _I	8	analog input voltage
V _{RT}	9	reference voltage TOP input
n.c.	10	not connected
O/UF	11	overflow/underflow data output
D7	12	data output; bit 7 (MSB)
D6	13	data output; bit 6
D5	14	data output; bit 5
D4	15	data output; bit 4
CLK	16	clock input
DGND	17	digital ground
V _{CCD}	18	digital supply voltage (+5 V)
V _{CCO1}	19	supply voltage for output stages 1 (+5 V)
OGND	20	output ground
V _{CCO2}	21	supply voltage for output stages 2 (+5 V)
\overline{CE}	22	chip enable input (TTL level input, active LOW)
D3	23	data output; bit 3
D2	24	data output; bit 2

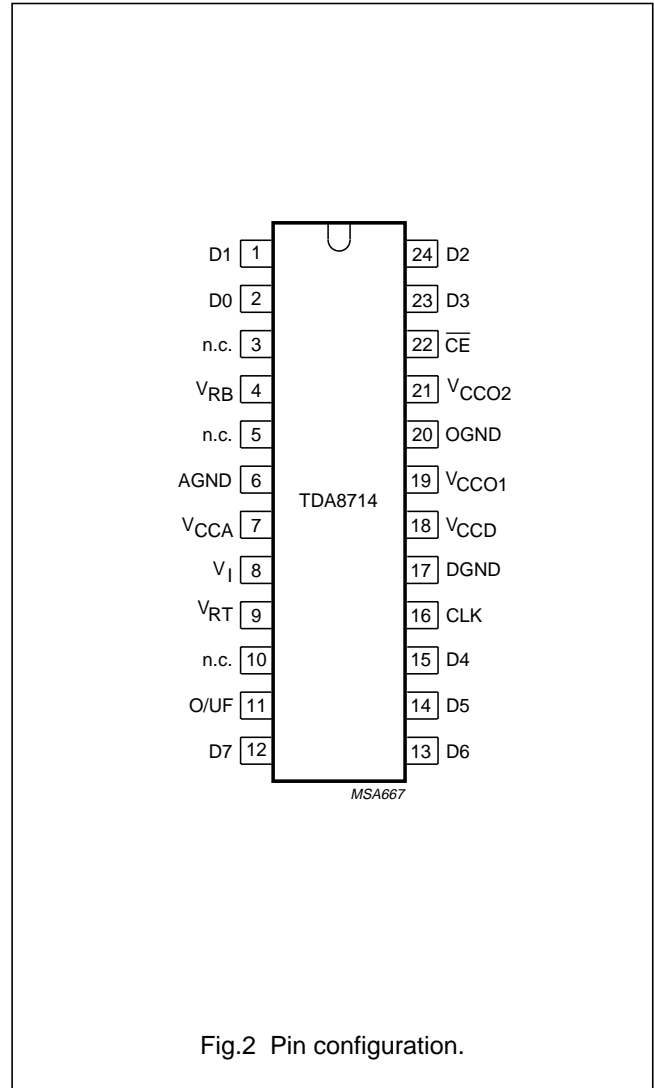

Fig.2 Pin configuration.

8-bit high-speed analog-to-digital converter

TDA8714

LIMITING VALUES

In accordance with the Absolute Maximum Rating System (IEC 134).

SYMBOL	PARAMETER	CONDITIONS	MIN.	MAX.	UNIT
V_{CCA}	analog supply voltage	note 1	-0.3	+7.0	V
V_{CCD}	digital supply voltage	note 1	-0.3	+7.0	V
V_{CCO}	output stages supply voltage	note 1	-0.3	+7.0	V
ΔV_{CC}	supply voltage differences between V_{CCA} and V_{CCD}		-1.0	+1.0	V
ΔV_{CC}	supply voltage differences between V_{CCO} and V_{CCD}		-1.0	+1.0	V
ΔV_{CC}	supply voltage differences between V_{CCA} and V_{CCO}		-1.0	+1.0	V
V_I	input voltage	referenced to AGND	-0.3	+7.0	V
$V_{clk(p-p)}$	AC input voltage for switching (peak-to-peak value)	referenced to DGND	-	V_{CCD}	V
I_O	output current		-	10	mA
T_{stg}	storage temperature		-55	+150	°C
T_{amb}	operating ambient temperature		0	+70	°C
T_j	junction temperature		-	+150	°C

Note

- The supply voltages V_{CCA} and V_{CCD} may have any value between -0.3 V and +7.0 V provided the difference between V_{CCA} and V_{CCD} is between -1 V and +1 V.

HANDLING

Inputs and outputs are protected against electrostatic discharges in normal handling. However, to be totally safe, it is desirable to take normal precautions appropriate to handling integrated circuits.

THERMAL CHARACTERISTICS

SYMBOL	PARAMETER	VALUE	UNIT
$R_{th\ j-a}$	thermal resistance from junction to ambient in free air		
	SOT137-1	75	K/W
	SOT340-1	119	K/W

8-bit high-speed analog-to-digital converter

TDA8714

CHARACTERISTICS

$V_{CCA} = V_7$ to $V_6 = 4.75$ to 5.25 V; $V_{CCD} = V_{18}$ to $V_{17} = 4.75$ to 5.25 V; $V_{CCO} = V_{19}$ and V_{21} to $V_{20} = 4.75$ to 5.25 V; AGND and DGND shorted together; V_{CCA} to $V_{CCD} = -0.25$ to $+0.25$ V; V_{CCO} to $V_{CCD} = -0.25$ to $+0.25$ V; V_{CCA} to $V_{CCO} = -0.25$ to $+0.25$ V; $V_{i(p-p)} = 1.75$ V; $T_{amb} = 0$ to $+70$ °C; typical values measured at $V_{CCA} = V_{CCD} = V_{CCO} = 5$ V and $T_{amb} = 25$ °C; unless otherwise specified.

SYMBOL	PARAMETER	CONDITIONS	MIN.	TYP.	MAX.	UNIT
Supply						
V_{CCA}	analog supply voltage		4.75	5.0	5.25	V
V_{CCD}	digital supply voltage		4.75	5.0	5.25	V
V_{CCO}	output stages supply voltage		4.75	5.0	5.25	V
I_{CCA}	analog supply current		–	25	30	mA
I_{CCD}	digital supply current		–	27	33	mA
I_{CCO}	output stages supply current		–	16	20	mA
Inputs						
CLOCK INPUT CLK (REFERENCED TO DGND); note 1						
V_{IL}	LOW level input voltage		0	–	0.8	V
V_{IH}	HIGH level input voltage		2.0	–	V_{CCD}	V
I_{IL}	LOW level input current	$V_{clk} = 0.4$ V	–400	–	–	µA
I_{IH}	HIGH level input current	$V_{clk} = 2.7$ V	–	–	300	µA
Z_I	input impedance	$f_{clk} = 80$ MHz	–	18	–	kΩ
C_I	input capacitance	$f_{clk} = 80$ MHz	–	1	–	pF
INPUT \overline{CE} (REFERENCED TO DGND); see Table 2						
V_{IL}	LOW level input voltage		0	–	0.8	V
V_{IH}	HIGH level input voltage		2.0	–	V_{CCD}	V
I_{IL}	LOW level input current	$V_{IL} = 0.4$ V	–400	–	–	µA
I_{IH}	HIGH level input current	$V_{IH} = 2.7$ V	–	–	20	µA
V_I (ANALOG INPUT VOLTAGE REFERENCED TO AGND)						
I_{IL}	LOW level input current	$V_I = 1.2$ V	–	0	–	µA
I_{IH}	HIGH level input current	$V_I = 3.5$ V	60	130	280	µA
Z_I	input impedance	$f_i = 4.43$ MHz	–	10	–	kΩ
C_I	input capacitance	$f_i = 4.43$ MHz	–	14	–	pF
Reference voltages for the resistor ladder; see Table 1						
V_{RB}	reference voltage BOTTOM		1.2	1.3	1.6	V
V_{RT}	reference voltage TOP		3.5	3.6	3.9	V
V_{diff}	differential reference voltage $V_{RT} - V_{RB}$		1.9	2.3	2.7	V
I_{ref}	reference current		–	11.5	–	mA
R_{LAD}	resistor ladder		–	200	–	Ω
TC_{RLAD}	temperature coefficient of the resistor ladder		–	0.24	–	ppm
V_{osB}	offset voltage BOTTOM	note 2	275	285	295	mV
V_{osT}	offset voltage TOP	note 2	305	315	325	mV
$V_{i(p-p)}$	analog input voltage (peak-to-peak value)		1.45	1.75	2.15	V

8-bit high-speed analog-to-digital converter

TDA8714

SYMBOL	PARAMETER	CONDITIONS	MIN.	TYP.	MAX.	UNIT
Outputs						
DIGITAL OUTPUTS D7 to D0 (REFERENCED TO DGND)						
V_{OL}	LOW level output voltage	$I_O = 1 \text{ mA}$	0	–	0.4	V
V_{OH}	HIGH level output voltage	$I_O = -0.4 \text{ mA}$	2.7	–	V_{CCD}	V
		$I_O = -1 \text{ mA}$	2.4	–	V_{CCD}	V
I_{OZ}	output current in 3-state mode	$0.4 \text{ V} < V_O < V_{CCD}$	–20	–	+20	μA
Switching characteristics						
CLOCK INPUT CLK (note 1; see Fig.3)						
$f_{clk(max)}$	maximum clock frequency					
	TDA8714/4		40	–	–	MHz
	TDA8714/6		60	–	–	MHz
	TDA8714/7		80	–	–	MHz
t_{CPH}	clock pulse width HIGH		6	–	–	ns
t_{CPL}	clock pulse width LOW		6	–	–	ns
Analog signal processing						
LINEARITY						
INL	DC integral non-linearity		–	± 0.4	± 0.5	LSB
DNL	DC differential non-linearity		–	± 0.2	± 0.35	LSB
AINL	AC integral non-linearity	note 3	–	± 0.5	± 1.0	LSB
BANDWIDTH ($f_{clk} = 40 \text{ MHz}$); note 4						
B	analog bandwidth	full-scale sine wave	–	13	–	MHz
		75% full-scale sine wave; small signal at $V_i = \pm 5 \text{ LSB}$, code 128	–	20	–	MHz
t_{STLH}	analog input settling time LOW-to-HIGH	full-scale square wave; Fig.6; note 5	–	2.5	3.5	ns
t_{STHL}	analog input settling time HIGH-to-LOW	full-scale square wave; Fig.6; note 5	–	3.0	4.0	ns
HARMONICS ($f_{clk} = 40 \text{ MHz}$)						
h_1	fundamental harmonics (full scale)	$f_i = 4.43 \text{ MHz}$	–	–	0	dB
h_{all}	harmonics (full scale); all components	$f_i = 4.43 \text{ MHz}$				
	second harmonics		–	–64	–60	dB
	third harmonics		–	–58	–55	dB
THD	total harmonic distortion	$f_i = 4.43 \text{ MHz}$	–	–56	–	dB
SIGNAL-TO-NOISE RATIO (note 6; see Figs 7 and 13)						
S/N	signal-to-noise ratio (full scale)	without harmonics; $f_{clk} = 40 \text{ MHz}$; $f_i = 4.43 \text{ MHz}$	46	48	–	dB

8-bit high-speed analog-to-digital converter

TDA8714

SYMBOL	PARAMETER	CONDITIONS	MIN.	TYP.	MAX.	UNIT	
EFFECTIVE BITS (note 6; see Figs 7 and 13)							
EB	effective bits TDA8714/4	$f_{\text{clk}} = 40 \text{ MHz}$					
		$f_i = 4.43 \text{ MHz}$	–	7.75	–	bits	
		$f_i = 7.5 \text{ MHz}$	–	7.6	–	bits	
	effective bits TDA8714/6	$f_{\text{clk}} = 60 \text{ MHz}$					
		$f_i = 4.43 \text{ MHz}$	–	7.7	–	bits	
		$f_i = 7.5 \text{ MHz}$	–	7.55	–	bits	
		$f_i = 10 \text{ MHz}$	–	7.4	–	bits	
	effective bits TDA8714/7	$f_{\text{clk}} = 80 \text{ MHz}$					
		$f_i = 4.43 \text{ MHz}$	–	7.7	–	bits	
$f_i = 7.5 \text{ MHz}$		–	7.5	–	bits		
$f_i = 10 \text{ MHz}$		–	7.2	–	bits		
	$f_i = 15 \text{ MHz}$	–	6.3	–	bits		
TWO-TONE (note 7)							
TTIR	two-tone intermodulation rejection	$f_{\text{clk}} = 40 \text{ MHz}$	–	–56	–	dB	
BIT ERROR RATE							
BER	bit error rate	$f_{\text{clk}} = 40 \text{ MHz};$ $f_i = 4.43 \text{ MHz};$ $V_I = \pm 16 \text{ LSB at}$ code 128	–	10^{-11}	–	times/ samples	
DIFFERENTIAL GAIN (note 8)							
G_{diff}	differential gain	$f_{\text{clk}} = 40 \text{ MHz};$ $f_i = 4.43 \text{ MHz}$	–	0.6	–	%	
DIFFERENTIAL PHASE (note 8)							
φ_{diff}	differential phase	$f_{\text{clk}} = 40 \text{ MHz};$ $f_i = 4.43 \text{ MHz}$	–	0.8	–	deg	
Timing (note 9; see Figs 3 and 5; $f_{\text{clk}} = 80 \text{ MHz}$)							
t_{ds}	sampling delay time		–	–	2	ns	
t_{h}	output hold time		5	–	–	ns	
t_{d}	output delay time		–	10	11	ns	
3-state output delay times (see Fig.4)							
t_{dZH}	enable HIGH		–	40	44	ns	
t_{dZL}	enable LOW		–	12	16	ns	
t_{dHZ}	disable HIGH		–	50	54	ns	
t_{dLZ}	disable LOW		–	10	14	ns	

8-bit high-speed analog-to-digital converter

TDA8714

Notes to the characteristics

1. In addition to a good layout of the digital and analog ground, it is recommended that the rise and fall times of the clock must not be less than 1 ns.
2. Analog input voltages producing code 00 up to and including FF:
 - a) V_{osB} (voltage offset BOTTOM) is the difference between the analog input which produces data equal to 00 and the reference voltage BOTTOM (V_{RB}) at $T_{amb} = 25\text{ }^{\circ}\text{C}$.
 - b) V_{osT} (voltage offset TOP) is the difference between V_{RT} (reference voltage TOP) and the analog input which produces data outputs equal to FF at $T_{amb} = 25\text{ }^{\circ}\text{C}$.
3. Full-scale sine wave ($f_i = 4.43\text{ MHz}$; $f_{clk} = 80\text{ MHz}$).
4. The analog bandwidth is defined as the maximum input sine wave frequency which can be applied to the device. No glitches greater than 2 LSBs, neither any significant attenuation are observed in the reconstructed signal.
5. The analog input settling time is the minimum time required for the input signal to be stabilized after a sharp full-scale input (square-wave signal) in order to sample the signal and obtain correct output data.
6. Effective bits are obtained via a Fast Fourier Transform (FFT) treatment taking 8K acquisition points per equivalent fundamental period. The calculation takes into account all harmonics and noise up to half of the clock frequency (NYQUIST frequency). Conversion to signal-to-noise ratio: $S/N = EB \times 6.02 + 1.76\text{ dB}$.
7. Intermodulation measured relative to either tone with analog input frequencies of 4.43 MHz and 4.53 MHz. The two input signals have the same amplitude and the total amplitude of both signals provides full scale to the converter.
8. Measurement carried out using video analyser VM700A where the video analog signal is reconstructed through a digital-to-analog converter.
9. Output data acquisition: the output data is available after the maximum delay time of t_d ; in the event of 80 MHz clock operation, the hardware design must take into account the t_d and t_h limits with respect to the input characteristics of the acquisition circuit.

8-bit high-speed analog-to-digital converter

TDA8714

Table 1 Output coding and input voltage (typical values; referenced to AGND)

STEP	$V_{I(p-p)}$	O/UF	BINARY OUTPUT BITS							
			D7	D6	D5	D4	D3	D2	D1	D0
Underflow	<1.585	1	0	0	0	0	0	0	0	0
0	1.585	0	0	0	0	0	0	0	0	0
1	.	0	0	0	0	0	0	0	0	1
.
.
254	.	0	1	1	1	1	1	1	1	0
255	3.28	0	1	1	1	1	1	1	1	1
Overflow	>3.28	1	1	1	1	1	1	1	1	1

Table 2 Mode selection

\overline{CE}	D7 to D0	O/UF
1	high impedance	high impedance
0	active; binary	active

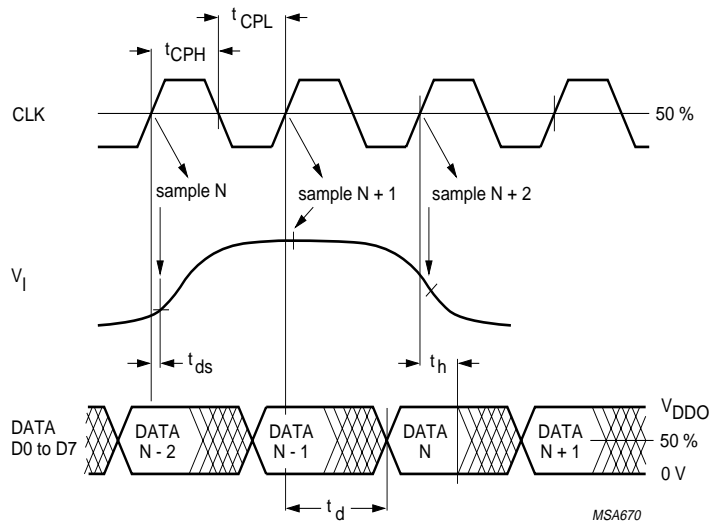

Fig.3 Timing diagram.

8-bit high-speed analog-to-digital converter

TDA8714

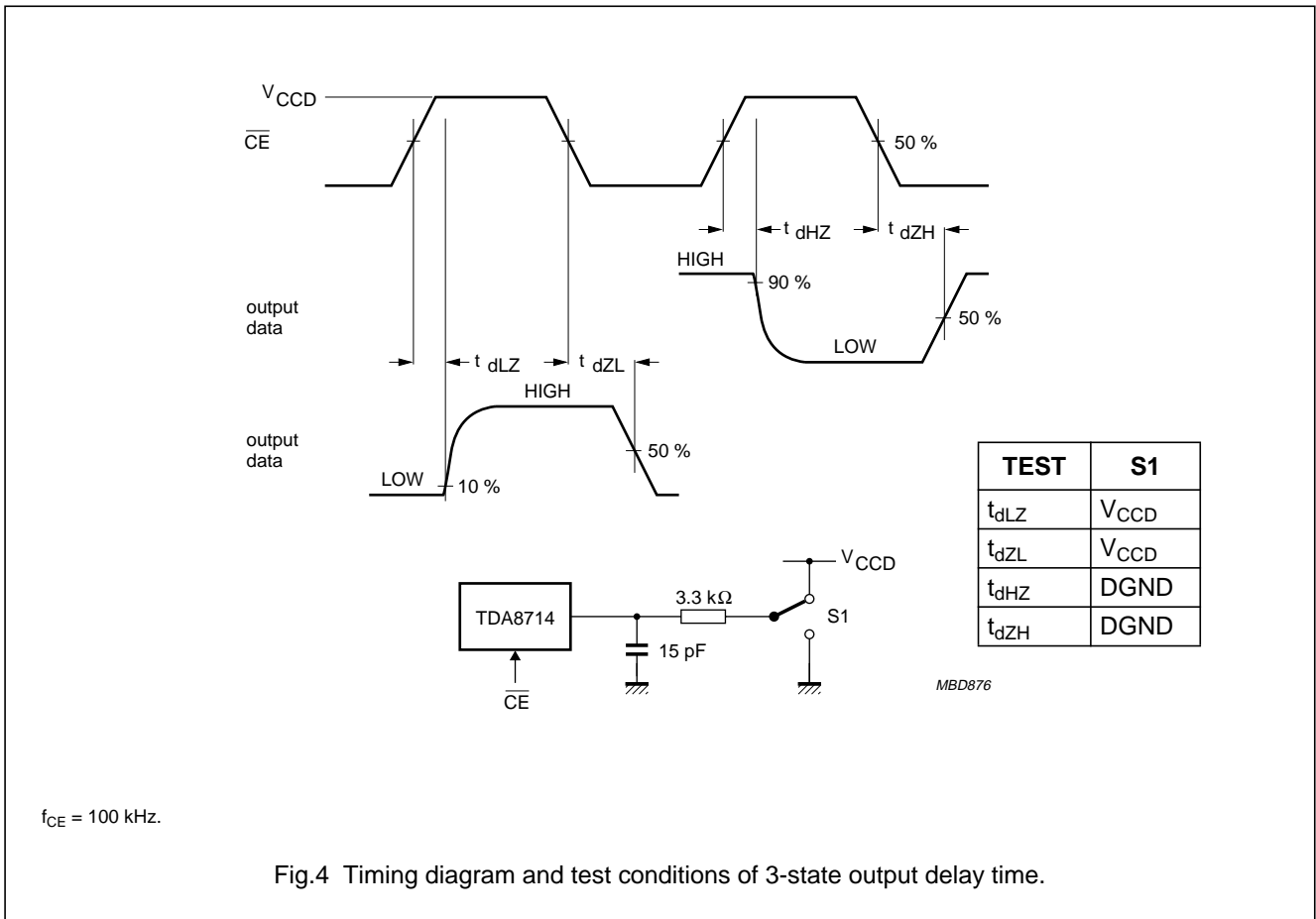

Fig.4 Timing diagram and test conditions of 3-state output delay time.

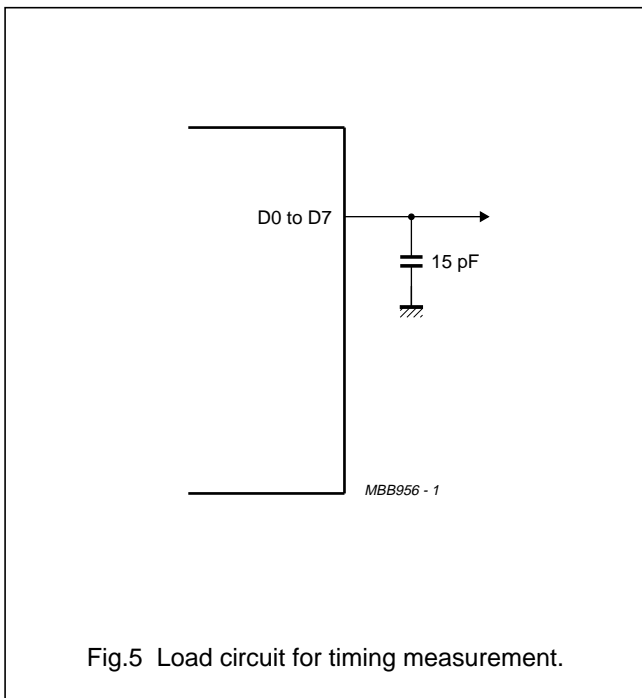

Fig.5 Load circuit for timing measurement.

8-bit high-speed analog-to-digital converter

TDA8714

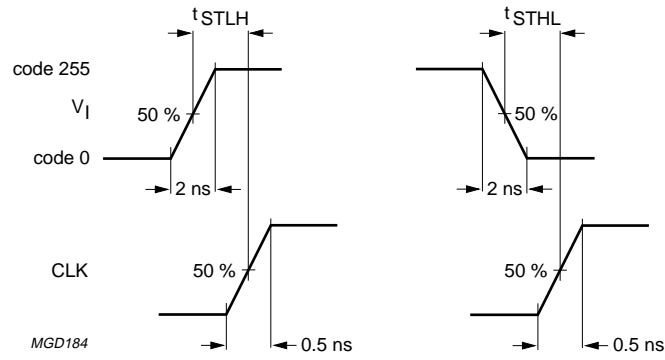
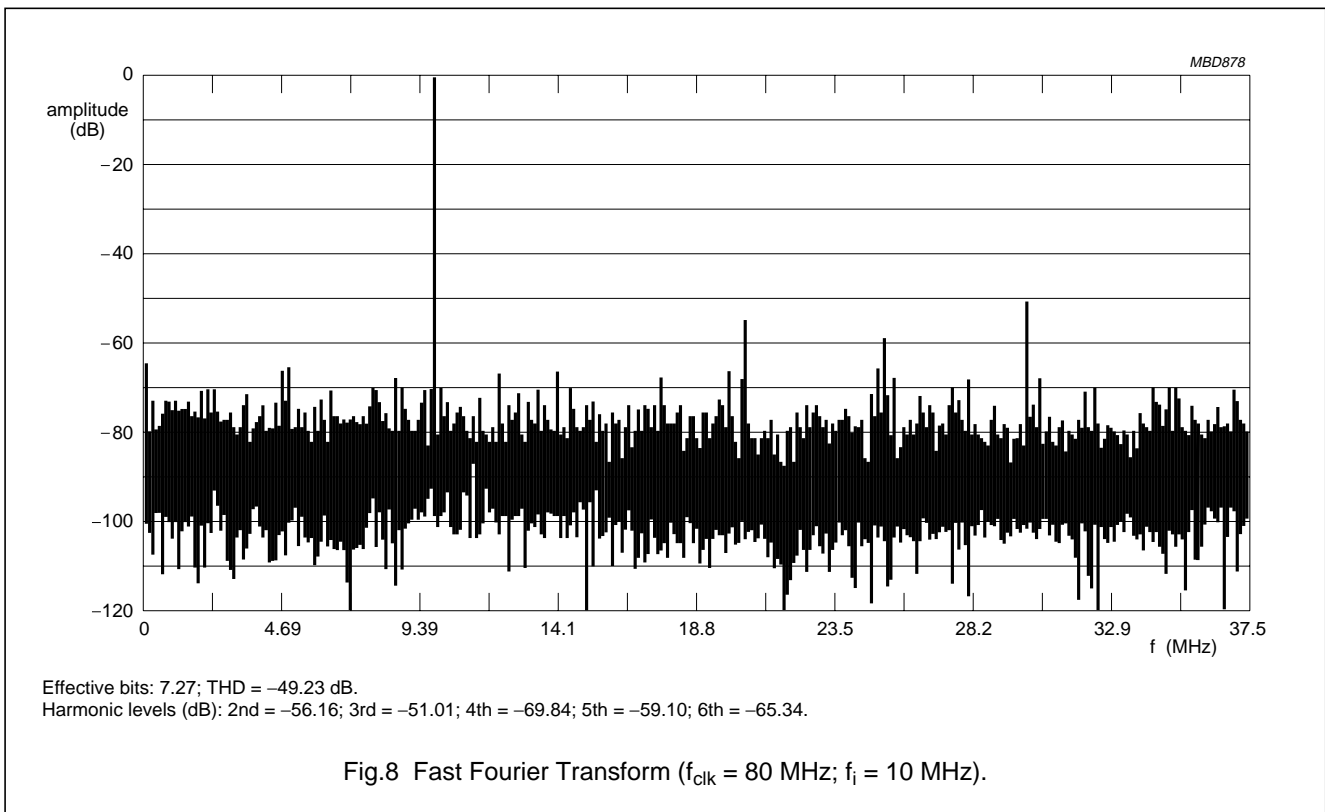
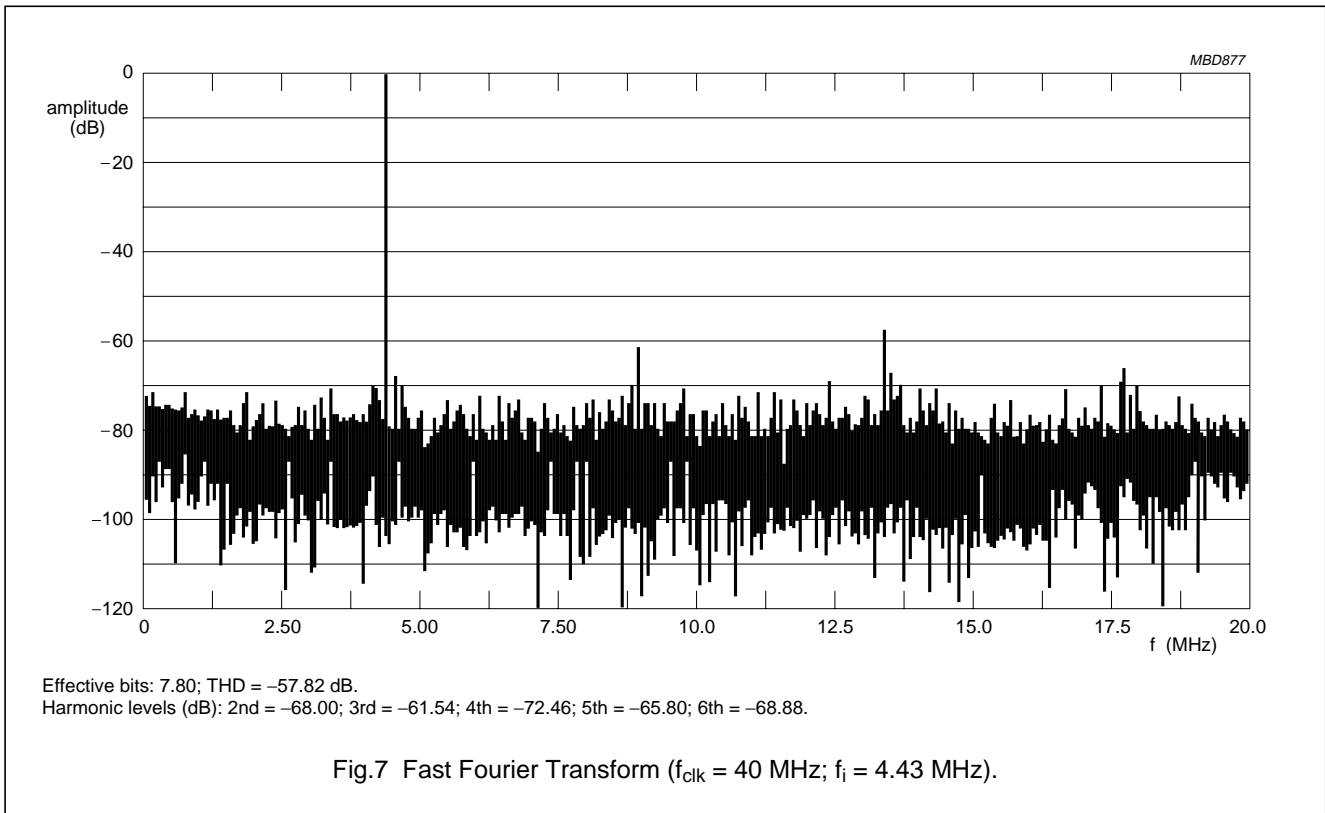

Fig.6 Analog input settling-time diagram.

8-bit high-speed analog-to-digital converter

TDA8714



8-bit high-speed analog-to-digital converter

TDA8714

INTERNAL PIN CONFIGURATIONS

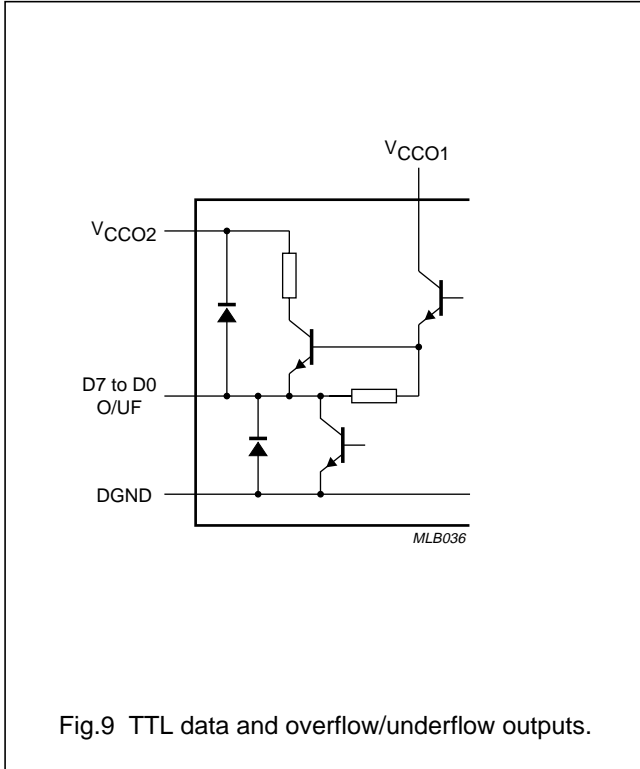

Fig.9 TTL data and overflow/underflow outputs.

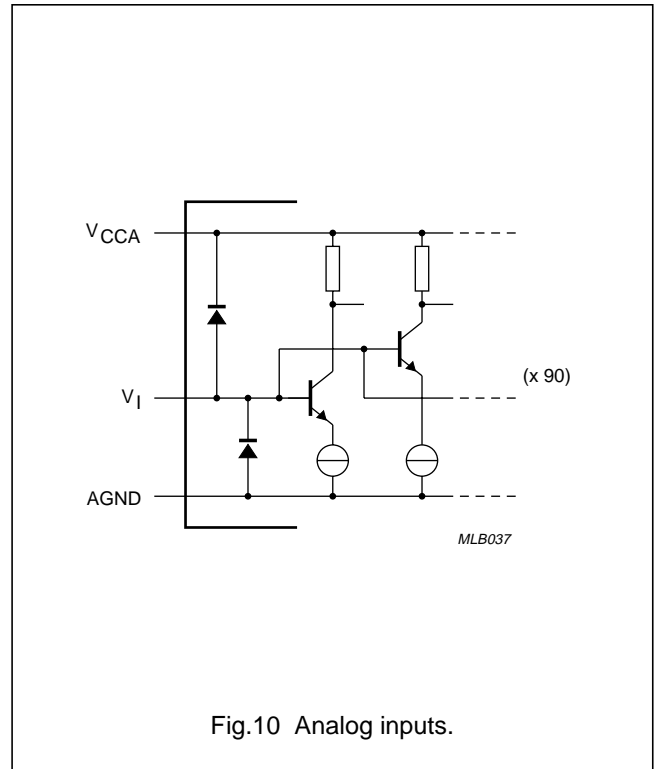

Fig.10 Analog inputs.

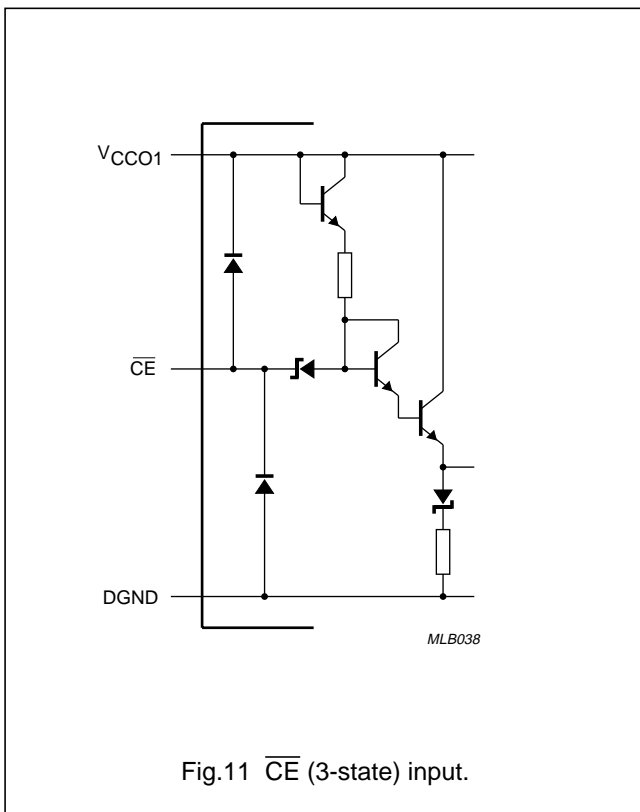

Fig.11 \overline{CE} (3-state) input.

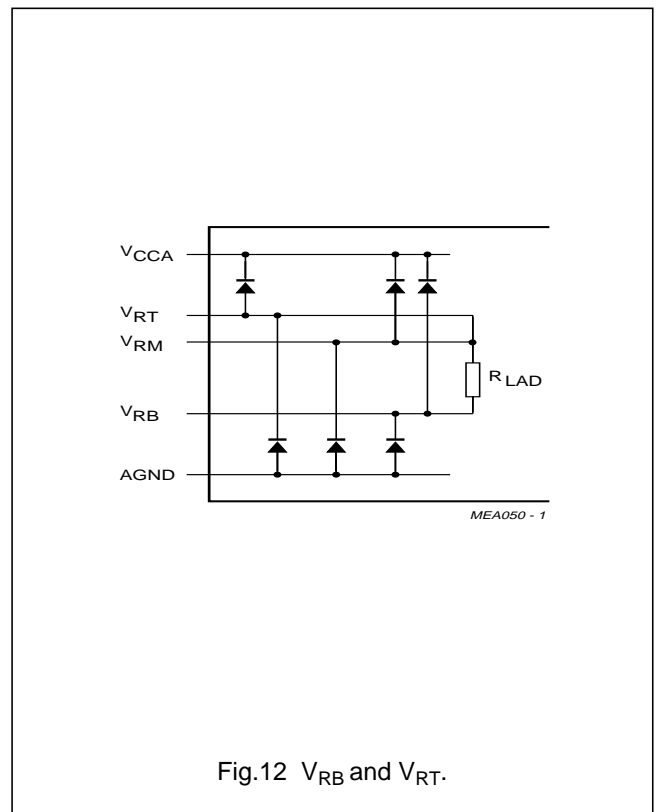

Fig.12 V_{RB} and V_{RT}.

8-bit high-speed analog-to-digital converter

TDA8714

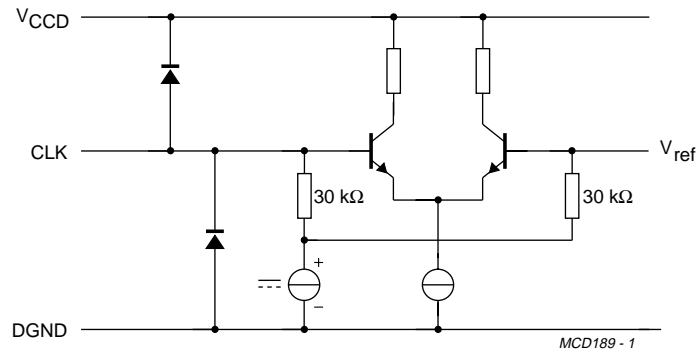
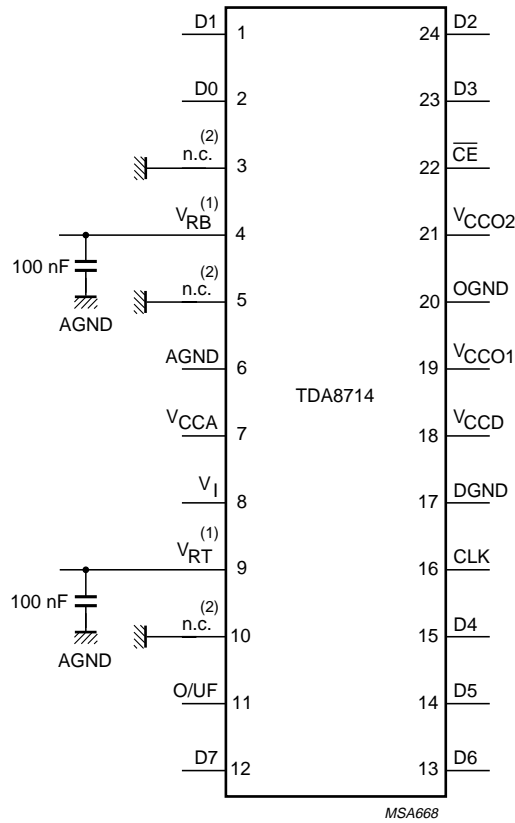

Fig.13 CLK input.

8-bit high-speed analog-to-digital converter

TDA8714

APPLICATION INFORMATION



The analog and digital supplies should be separated and decoupled.

The external voltage generator must be built such that a good supply voltage ripple rejection is achieved with respect to the LSB value.

(1) V_{RB} and V_{RT} are decoupled to AGND.

(2) Pin 5 should be connected to AGND; pins 3 and 10 to DGND in order to prevent noise influence.

Fig.14 Application diagram.

8-bit high-speed analog-to-digital converter

TDA8714

PACKAGE OUTLINES

SO24: plastic small outline package; 24 leads; body width 7.5 mm

SOT137-1

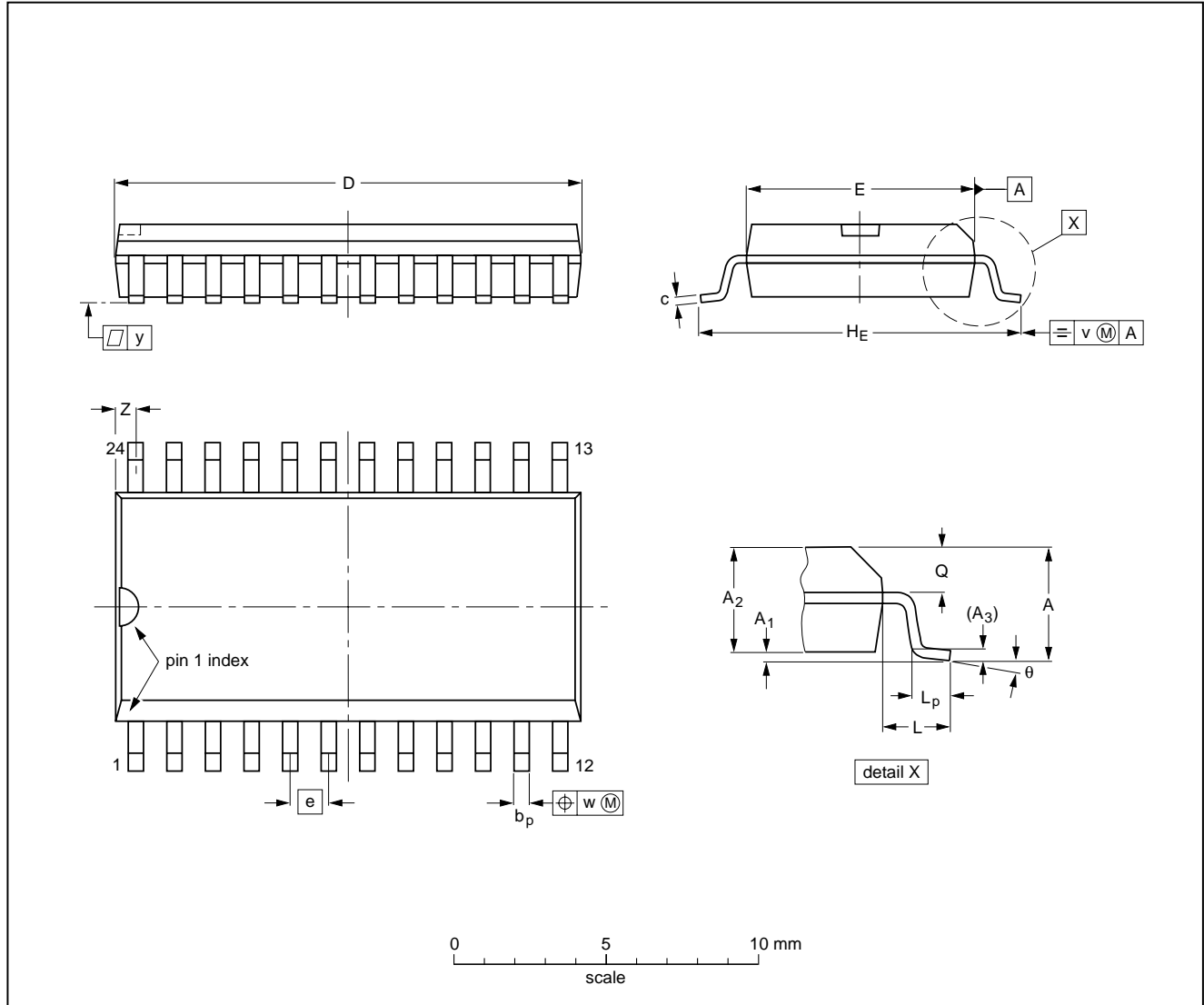

DIMENSIONS (inch dimensions are derived from the original mm dimensions)

UNIT	A max.	A ₁	A ₂	A ₃	b _p	c	D ⁽¹⁾	E ⁽¹⁾	e	H _E	L	L _p	Q	v	w	y	Z ⁽¹⁾	θ
mm	2.65	0.30 0.10	2.45 2.25	0.25	0.49 0.36	0.32 0.23	15.6 15.2	7.6 7.4	1.27	10.65 10.00	1.4	1.1 0.4	1.1 1.0	0.25	0.25	0.1	0.9 0.4	8° 0°
inches	0.10	0.012 0.004	0.096 0.089	0.01	0.019 0.014	0.013 0.009	0.61 0.60	0.30 0.29	0.050	0.419 0.394	0.055	0.043 0.016	0.043 0.039	0.01	0.01	0.004	0.035 0.016	

Note

1. Plastic or metal protrusions of 0.15 mm maximum per side are not included.

OUTLINE VERSION	REFERENCES				EUROPEAN PROJECTION	ISSUE DATE
	IEC	JEDEC	EIAJ			
SOT137-1	075E05	MS-013AD				95-01-24 97-05-22

8-bit high-speed analog-to-digital converter

TDA8714

SSOP24: plastic shrink small outline package; 24 leads; body width 5.3 mm

SOT340-1

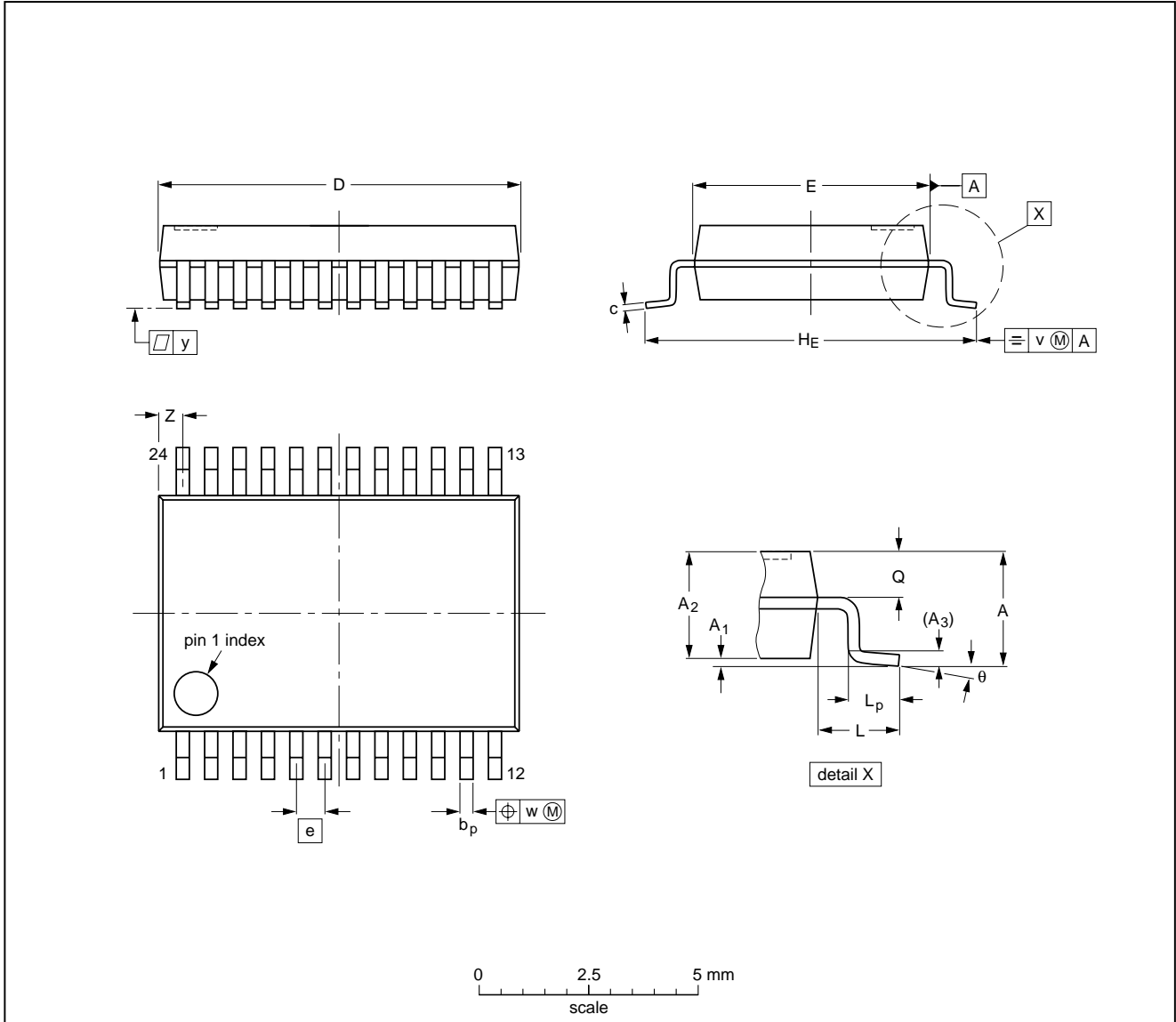

DIMENSIONS (mm are the original dimensions)

UNIT	A max.	A ₁	A ₂	A ₃	b _p	c	D ⁽¹⁾	E ⁽¹⁾	e	H _E	L	L _p	Q	v	w	y	Z ⁽¹⁾	θ
mm	2.0	0.21 0.05	1.80 1.65	0.25	0.38 0.25	0.20 0.09	8.4 8.0	5.4 5.2	0.65	7.9 7.6	1.25	1.03 0.63	0.9 0.7	0.2	0.13	0.1	0.8 0.4	8° 0°

Note

1. Plastic or metal protrusions of 0.20 mm maximum per side are not included.

OUTLINE VERSION	REFERENCES				EUROPEAN PROJECTION	ISSUE DATE
	IEC	JEDEC	EIAJ			
SOT340-1		MO-150AG				93-09-08 95-02-04

8-bit high-speed analog-to-digital converter

TDA8714

SOLDERING

Introduction

There is no soldering method that is ideal for all IC packages. Wave soldering is often preferred when through-hole and surface mounted components are mixed on one printed-circuit board. However, wave soldering is not always suitable for surface mounted ICs, or for printed-circuits with high population densities. In these situations reflow soldering is often used.

This text gives a very brief insight to a complex technology. A more in-depth account of soldering ICs can be found in our "IC Package Databook" (order code 9398 652 90011).

Reflow soldering

Reflow soldering techniques are suitable for all SO and SSOP packages.

Reflow soldering requires solder paste (a suspension of fine solder particles, flux and binding agent) to be applied to the printed-circuit board by screen printing, stencilling or pressure-syringe dispensing before package placement.

Several techniques exist for reflowing; for example, thermal conduction by heated belt. Dwell times vary between 50 and 300 seconds depending on heating method. Typical reflow temperatures range from 215 to 250 °C.

Preheating is necessary to dry the paste and evaporate the binding agent. Preheating duration: 45 minutes at 45 °C.

Wave soldering

SO

Wave soldering techniques can be used for all SO packages if the following conditions are observed:

- A double-wave (a turbulent wave with high upward pressure followed by a smooth laminar wave) soldering technique should be used.
- The longitudinal axis of the package footprint must be parallel to the solder flow.
- The package footprint must incorporate solder thieves at the downstream end.

SSOP

Wave soldering is **not** recommended for SSOP packages. This is because of the likelihood of solder bridging due to closely-spaced leads and the possibility of incomplete solder penetration in multi-lead devices.

If wave soldering cannot be avoided, the following conditions must be observed:

- **A double-wave (a turbulent wave with high upward pressure followed by a smooth laminar wave) soldering technique should be used.**
- **The longitudinal axis of the package footprint must be parallel to the solder flow and must incorporate solder thieves at the downstream end.**

Even with these conditions, only consider wave soldering SSOP packages that have a body width of 4.4 mm, that is SSOP16 (SOT369-1) or SSOP20 (SOT266-1).

METHOD (SO AND SSOP)

During placement and before soldering, the package must be fixed with a droplet of adhesive. The adhesive can be applied by screen printing, pin transfer or syringe dispensing. The package can be soldered after the adhesive is cured.

Maximum permissible solder temperature is 260 °C, and maximum duration of package immersion in solder is 10 seconds, if cooled to less than 150 °C within 6 seconds. Typical dwell time is 4 seconds at 250 °C.

A mildly-activated flux will eliminate the need for removal of corrosive residues in most applications.

Repairing soldered joints

Fix the component by first soldering two diagonally-opposite end leads. Use only a low voltage soldering iron (less than 24 V) applied to the flat part of the lead. Contact time must be limited to 10 seconds at up to 300 °C. When using a dedicated tool, all other leads can be soldered in one operation within 2 to 5 seconds between 270 and 320 °C.

8-bit high-speed analog-to-digital converter

TDA8714

DEFINITIONS

Data sheet status	
Objective specification	This data sheet contains target or goal specifications for product development.
Preliminary specification	This data sheet contains preliminary data; supplementary data may be published later.
Product specification	This data sheet contains final product specifications.
Limiting values	
Limiting values given are in accordance with the Absolute Maximum Rating System (IEC 134). Stress above one or more of the limiting values may cause permanent damage to the device. These are stress ratings only and operation of the device at these or at any other conditions above those given in the Characteristics sections of the specification is not implied. Exposure to limiting values for extended periods may affect device reliability.	
Application information	
Where application information is given, it is advisory and does not form part of the specification.	

LIFE SUPPORT APPLICATIONS

These products are not designed for use in life support appliances, devices, or systems where malfunction of these products can reasonably be expected to result in personal injury. Philips customers using or selling these products for use in such applications do so at their own risk and agree to fully indemnify Philips for any damages resulting from such improper use or sale.

8-bit high-speed analog-to-digital converter

TDA8714

NOTES

8-bit high-speed analog-to-digital converter

TDA8714

NOTES

8-bit high-speed analog-to-digital converter

TDA8714

NOTES

Philips Semiconductors – a worldwide company

Argentina: see South America

Australia: 34 Waterloo Road, NORTH RYDE, NSW 2113,
Tel. +61 2 9805 4455, Fax. +61 2 9805 4466

Austria: Computerstr. 6, A-1101 WIEN, P.O. Box 213, Tel. +43 160 1010,
Fax. +43 160 101 1210

Belarus: Hotel Minsk Business Center, Bld. 3, r. 1211, Volodarski Str. 6,
220050 MINSK, Tel. +375 172 200 733, Fax. +375 172 200 773

Belgium: see The Netherlands

Brazil: see South America

Bulgaria: Philips Bulgaria Ltd., Energoproject, 15th floor,
51 James Bourchier Blvd., 1407 SOFIA,
Tel. +359 2 689 211, Fax. +359 2 689 102

Canada: PHILIPS SEMICONDUCTORS/COMPONENTS,
Tel. +1 800 234 7381

China/Hong Kong: 501 Hong Kong Industrial Technology Centre,
72 Tat Chee Avenue, Kowloon Tong, HONG KONG,
Tel. +852 2319 7888, Fax. +852 2319 7700

Colombia: see South America

Czech Republic: see Austria

Denmark: Prags Boulevard 80, PB 1919, DK-2300 COPENHAGEN S,
Tel. +45 32 88 2636, Fax. +45 31 57 0044

Finland: Sinikalliontie 3, FIN-02630 ESPOO,
Tel. +358 9 615800, Fax. +358 9 61580920

France: 4 Rue du Port-aux-Vins, BP317, 92156 SURESNES Cedex,
Tel. +33 1 40 99 6161, Fax. +33 1 40 99 6427

Germany: Hammerbrookstraße 69, D-20097 HAMBURG,
Tel. +49 40 23 53 60, Fax. +49 40 23 536 300

Greece: No. 15, 25th March Street, GR 17778 TAVROS/ATHENS,
Tel. +30 1 4894 339/239, Fax. +30 1 4814 240

Hungary: see Austria

India: Philips INDIA Ltd, Band Box Building, 2nd floor,
254-D, Dr. Annie Besant Road, Worli, MUMBAI 400 025,
Tel. +91 22 493 8541, Fax. +91 22 493 0966

Indonesia: see Singapore

Ireland: Newstead, Clonskeagh, DUBLIN 14,
Tel. +353 1 7640 000, Fax. +353 1 7640 200

Israel: RAPAC Electronics, 7 Kehilat Saloniki St, PO Box 18053,
TEL AVIV 61180, Tel. +972 3 645 0444, Fax. +972 3 649 1007

Italy: PHILIPS SEMICONDUCTORS, Piazza IV Novembre 3,
20124 MILANO, Tel. +39 2 6752 2531, Fax. +39 2 6752 2557

Japan: Philips Bldg 13-37, Kohnan 2-chome, Minato-ku, TOKYO 108,
Tel. +81 3 3740 5130, Fax. +81 3 3740 5077

Korea: Philips House, 260-199 Itaewon-dong, Yongsan-ku, SEOUL,
Tel. +82 2 709 1412, Fax. +82 2 709 1415

Malaysia: No. 76 Jalan Universiti, 46200 PETALING JAYA, SELANGOR,
Tel. +60 3 750 5214, Fax. +60 3 757 4880

Mexico: 5900 Gateway East, Suite 200, EL PASO, TEXAS 79905,
Tel. +9-5 800 234 7381

Middle East: see Italy

Netherlands: Postbus 90050, 5600 PB EINDHOVEN, Bldg. VB,
Tel. +31 40 27 82785, Fax. +31 40 27 88399

New Zealand: 2 Wagener Place, C.P.O. Box 1041, AUCKLAND,
Tel. +64 9 849 4160, Fax. +64 9 849 7811

Norway: Box 1, Manglerud 0612, OSLO,
Tel. +47 22 74 8000, Fax. +47 22 74 8341

Philippines: Philips Semiconductors Philippines Inc.,
106 Valero St. Salcedo Village, P.O. Box 2108 MCC, MAKATI,
Metro MANILA, Tel. +63 2 816 6380, Fax. +63 2 817 3474

Poland: Ul. Lukiska 10, PL 04-123 WARSZAWA,
Tel. +48 22 612 2831, Fax. +48 22 612 2327

Portugal: see Spain

Romania: see Italy

Russia: Philips Russia, Ul. Usatcheva 35A, 119048 MOSCOW,
Tel. +7 095 755 6918, Fax. +7 095 755 6919

Singapore: Lorong 1, Toa Payoh, SINGAPORE 1231,
Tel. +65 350 2538, Fax. +65 251 6500

Slovakia: see Austria

Slovenia: see Italy

South Africa: S.A. PHILIPS Pty Ltd., 195-215 Main Road Martindale,
2092 JOHANNESBURG, P.O. Box 7430 Johannesburg 2000,
Tel. +27 11 470 5911, Fax. +27 11 470 5494

South America: Rua do Rocio 220, 5th floor, Suite 51,
04552-903 São Paulo, SÃO PAULO - SP, Brazil,
Tel. +55 11 821 2333, Fax. +55 11 829 1849

Spain: Balmes 22, 08007 BARCELONA,
Tel. +34 3 301 6312, Fax. +34 3 301 4107

Sweden: Kottbygatan 7, Akalla, S-16485 STOCKHOLM,
Tel. +46 8 632 2000, Fax. +46 8 632 2745

Switzerland: Allmendstrasse 140, CH-8027 ZÜRICH,
Tel. +41 1 488 2686, Fax. +41 1 481 7730

Taiwan: Philips Semiconductors, 6F, No. 96, Chien Kuo N. Rd., Sec. 1,
TAIPEI, Taiwan Tel. +886 2 2134 2865, Fax. +886 2 2134 2874

Thailand: PHILIPS ELECTRONICS (THAILAND) Ltd.,
209/2 Sanpavuth-Bangna Road Prakanong, BANGKOK 10260,
Tel. +66 2 745 4090, Fax. +66 2 398 0793

Turkey: Talatpasa Cad. No. 5, 80640 GÜLTEPE/ISTANBUL,
Tel. +90 212 279 2770, Fax. +90 212 282 6707

Ukraine: PHILIPS UKRAINE, 4 Patrice Lumumba str., Building B, Floor 7,
252042 KIEV, Tel. +380 44 264 2776, Fax. +380 44 268 0461

United Kingdom: Philips Semiconductors Ltd., 276 Bath Road, Hayes,
MIDDLESEX UB3 5BX, Tel. +44 181 730 5000, Fax. +44 181 754 8421

United States: 811 East Arques Avenue, SUNNYVALE, CA 94088-3409,
Tel. +1 800 234 7381

Uruguay: see South America

Vietnam: see Singapore

Yugoslavia: PHILIPS, Trg N. Pasica 5/v, 11000 BEOGRAD,
Tel. +381 11 625 344, Fax. +381 11 635 777

For all other countries apply to: Philips Semiconductors, Marketing & Sales Communications,
Building BE-p, P.O. Box 218, 5600 MD EINDHOVEN, The Netherlands, Fax. +31 40 27 24825

Internet: <http://www.semiconductors.philips.com>

© Philips Electronics N.V. 1997

SCA55

All rights are reserved. Reproduction in whole or in part is prohibited without the prior written consent of the copyright owner.

The information presented in this document does not form part of any quotation or contract, is believed to be accurate and reliable and may be changed without notice. No liability will be accepted by the publisher for any consequence of its use. Publication thereof does not convey nor imply any license under patent- or other industrial or intellectual property rights.

Printed in The Netherlands

547047/1200/06/pp24

Date of release: 1997 Oct 29

Document order number: 9397 750 02956

Let's make things better.

**Philips
Semiconductors**



PHILIPS