

DATA SHEET

TDA8767

**12-bit high-speed Analog-to-Digital
Converter (ADC)**

Preliminary specification
Supersedes data of 1997 Jun 27
File under Integrated Circuits, IC02

1999 Feb 16

12-bit high-speed Analog-to-Digital Converter (ADC)

TDA8767

FEATURES

- 12-bit resolution
- Sampling rate up to 30 MHz
- –3 dB bandwidth of 18 MHz
- No missing codes guaranteed
- 5 V power supplies
- Binary or two's complement CMOS outputs
- In-range CMOS output
- TTL/CMOS compatible static digital inputs
- 3 to 5 V CMOS digital outputs
- TTL compatible clock input
- Power dissipation 335 mW (typ.)
- Low analog input capacitance (typ. 2 pF), no buffer amplifier required
- No external sample-and-hold circuit required
- Differential or single analog Input
- External amplitude range control
- Voltage controlled regulator included.

APPLICATIONS

- High-speed analog-to-digital conversion for:
 - Video signal digitizing
 - High Definition TV (HDTV)
 - Imaging (camera, scanner)
 - Medical imaging
 - Telecommunication
 - Base-station receiver.

GENERAL DESCRIPTION

The TDA8767 is a bipolar 12-bit Analog-to-Digital Converter (ADC) for imaging or other applications. It converts the analog input signal into 12-bit binary coded digital words at a maximum sampling rate of 30 MHz. All digital inputs and outputs are CMOS compatible.

QUICK REFERENCE DATA

SYMBOL	PARAMETER	CONDITIONS	MIN.	TYP.	MAX.	UNIT
V _{CCA}	analog supply voltage		4.75	5.0	5.25	V
V _{CDD}	digital supply voltage		4.75	5.0	5.25	V
V _{CCO}	output supply voltage		3.0	3.3	5.25	V
I _{CCA}	analog supply current		–	40	tbf	mA
I _{CDD}	digital supply current		–	22	tbf	mA
I _{CCO}	output supply current	f _{clk} = 4 MHz; f _i = 400 kHz	–	3.2	tbf	mA
ILE	integral non-linearity	f _{clk} = 4 MHz; f _i = 400 kHz	–	±3.0	±4.0	LSB
DLE	differential non-linearity	f _{clk} = 4 MHz; f _i = 400 kHz; no missing codes	–	±0.6	±1	LSB
f _{clk(max)}	maximum clock frequency					
	TDA8767H/1		10	–	–	MHz
	TDA8767H/2		20	–	–	MHz
	TDA8767H/3		30	–	–	MHz
P _{tot}	total power dissipation		–	335	–	mW

12-bit high-speed Analog-to-Digital Converter (ADC)

TDA8767

ORDERING INFORMATION

TYPE NUMBER	PACKAGE			SAMPLING FREQUENCY (MHz)
	NAME	DESCRIPTION	VERSION	
TDA8767H/1	QFP44	plastic quad flat package; 44 leads (lead length 1.3 mm); body 10 × 10 × 1.75 mm	SOT307-2	10
TDA8767H/2				20
TDA8767H/3				30

BLOCK DIAGRAM

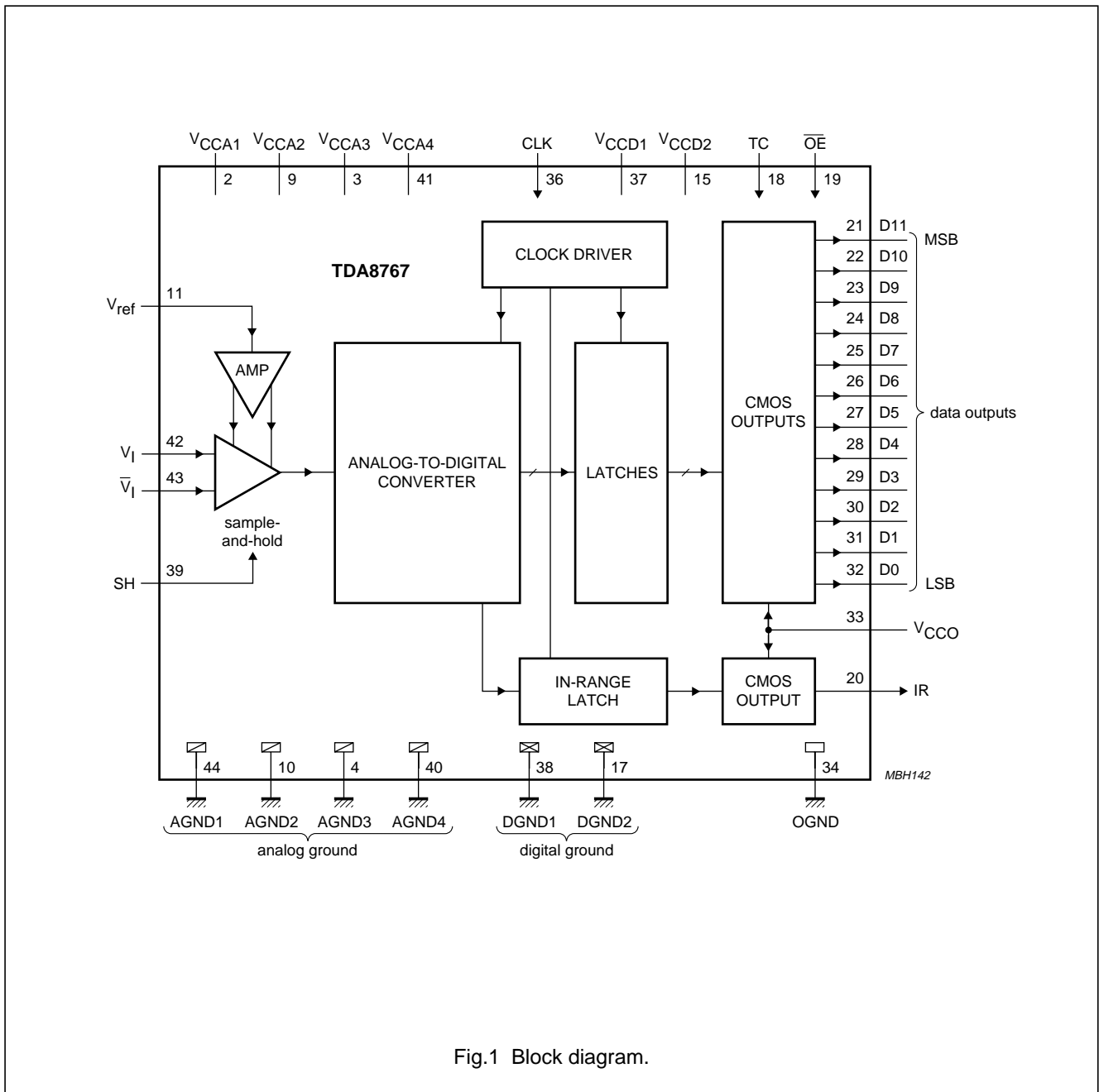

Fig.1 Block diagram.

12-bit high-speed Analog-to-Digital Converter (ADC)

TDA8767

PINNING

SYMBOL	PIN	DESCRIPTION
n.c.	1	not connected
V _{CCA1}	2	analog supply voltage 1 (+5 V)
V _{CCA3}	3	analog supply voltage 3 (+5 V)
AGND3	4	analog ground 3
n.c.	5	not connected
n.c.	6	not connected
n.c.	7	not connected
n.c.	8	not connected
V _{CCA2}	9	analog supply voltage 2 (+5 V)
AGND2	10	analog ground 2
V _{ref}	11	reference voltage
n.c.	12	not connected
n.c.	13	not connected
n.c.	14	not connected
V _{CCD2}	15	digital supply voltage 2 (+5 V)
n.c.	16	not connected
DGND2	17	digital ground 2
TC	18	output two's complement
$\overline{\text{OE}}$	19	output enable input (CMOS level; active LOW)
IR	20	in-range output
D11	21	data output; bit 11 (MSB)
D10	22	data output; bit 10

SYMBOL	PIN	DESCRIPTION
D9	23	data output; bit 9
D8	24	data output; bit 8
D7	25	data output; bit 7
D6	26	data output; bit 6
D5	27	data output; bit 5
D4	28	data output; bit 4
D3	29	data output; bit 3
D2	30	data output; bit 2
D1	31	data output; bit 1
D0	32	data output; bit 0 (LSB)
V _{CCO}	33	output supply voltage (3 to 5.25 V)
OGND	34	output ground
n.c.	35	not connected
CLK	36	clock input
V _{CCD1}	37	digital supply voltage 1 (+5 V)
DGND1	38	digital ground 1
SH	39	sample-and-hold enable input (CMOS level; active HIGH)
AGND4	40	analog ground 4
V _{CCA4}	41	analog supply voltage 4 (+5 V)
V _I	42	complementary analog input voltage
\overline{V}_I	43	analog input voltage
AGND1	44	analog ground 1

12-bit high-speed Analog-to-Digital Converter (ADC)

TDA8767

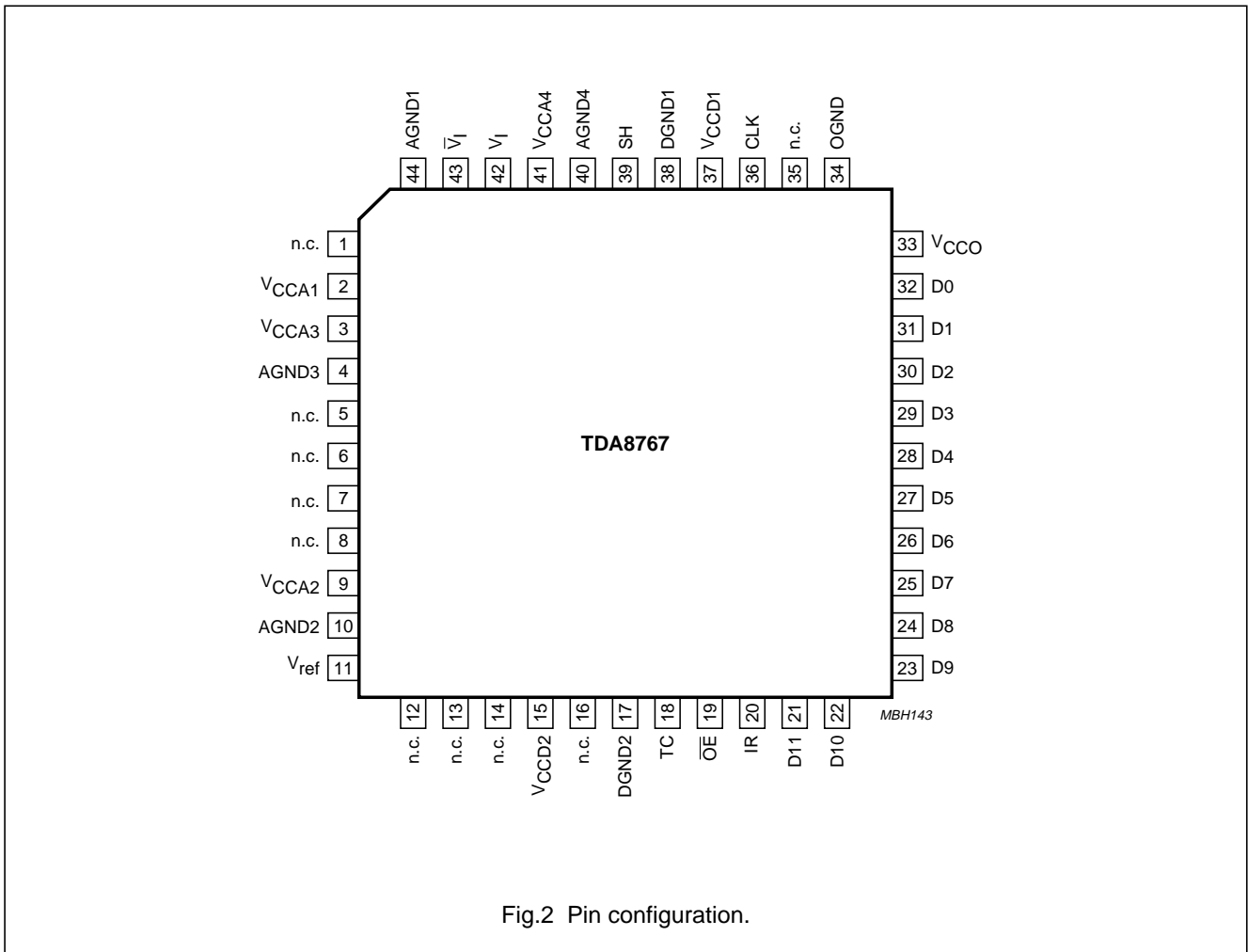

Fig.2 Pin configuration.

12-bit high-speed Analog-to-Digital Converter (ADC)

TDA8767

LIMITING VALUES

In accordance with the Absolute Maximum Rating System (IEC 134).

SYMBOL	PARAMETER	CONDITIONS	MIN.	MAX.	UNIT
V_{CCA}	analog supply voltage	note 1	-0.3	+7.0	V
V_{CCD}	digital supply voltage	note 1	-0.3	+7.0	V
V_{CCO}	output supply voltage	note 1	-0.3	+7.0	V
ΔV_{CC}	supply voltage difference				
	$V_{CCA} - V_{CCD}$		-1.0	+1.0	V
	$V_{CCO} - V_{CCD}$		-1.0	+4.0	V
	$V_{CCA} - V_{CCO}$		-1.0	+4.0	V
V_I	input voltage	referenced to AGND	0.3	V_{CCA}	V
$V_{i(p-p)}$	input voltage for differential clock drive (peak-to-peak value)		-	V_{CCD}	V
I_O	output current		-	10	mA
T_{stg}	storage temperature		-55	+150	°C
T_{amb}	operating ambient temperature		0	70	°C
T_j	junction temperature		-	+150	°C

Note

- The supply voltages V_{CCA} , V_{CCD} and V_{CCO} may have any value between -0.3 V and +7.0 V provided that the supply voltage differences ΔV_{CC} are respected.

HANDLING

Inputs and outputs are protected against electrostatic discharges in normal handling. However, to be totally safe, it is desirable to take normal precautions appropriate to handling integrated circuits.

THERMAL CHARACTERISTICS

SYMBOL	PARAMETER	VALUE (TYP.)	UNIT
$R_{th j-a}$	thermal resistance from junction to ambient in free air	75	K/W

12-bit high-speed Analog-to-Digital Converter (ADC)

TDA8767

CHARACTERISTICS

$V_{CCA} = V_2$ to V_{44} , V_9 to V_{10} , V_3 to V_4 and V_{41} to $V_{40} = 4.75$ to 5.25 V; $V_{CCD} = V_{37}$ to V_{38} and V_{15} to $V_{17} = 4.75$ to 5.25 V; $V_{CCO} = V_{33}$ to $V_{34} = 3.0$ to 5.25 V; AGND and DGND shorted together; $T_{amb} = 0$ to $+70$ °C; typical values measured at $V_{CCA} = V_{CCD} = 5$ V and $V_{CCO} = 3.3$ V; $V_{i(p-p)} - \bar{V}_{i(p-p)} = 2.0$ V; $C_L = 15$ pF and $T_{amb} = 25$ °C; unless otherwise specified.

SYMBOL	PARAMETER	CONDITIONS	MIN.	TYP.	MAX.	UNIT
Supply						
V_{CCA}	analog supply voltage		4.75	5.0	5.25	V
V_{CCD}	digital supply voltage		4.75	5.0	5.25	V
V_{CCO}	output supply voltage		3.0	3.3	5.25	V
I_{CCA}	analog supply current		–	40	tbf	mA
I_{CCD}	digital supply current		–	22	tbf	mA
I_{CCO}	output supply current	$f_{clk} = 20$ MHz; $f_i = 4.43$ MHz	–	12	tbf	mA
Inputs						
CLK (REFERENCED TO DGND)						
V_{IL}	LOW-level input voltage		0	–	0.8	V
V_{IH}	HIGH-level input voltage		2.0	–	V_{CCD}	V
I_{IL}	LOW-level input current	$V_{clk} = 0.3V_{CCD}$	–400	–	–	μ A
I_{IH}	HIGH-level input current	$V_{clk} = 0.7V_{CCD}$	–	–	100	μ A
		$V_{clk} = V_{CCD}$	–	–	300	μ A
Z_i	input impedance	$f_{clk} = 30$ MHz	–	2	–	k Ω
C_i	input capacitance	$f_{clk} = 30$ MHz	–	2	–	pF
TC; SH AND \overline{OE} (REFERENCED TO DGND); see Tables 3 and 4						
V_{IL}	LOW-level input voltage		0	–	0.8	V
V_{IH}	HIGH-level input voltage		2.0	–	V_{CCD}	V
I_{IL}	LOW-level input current	$V_{IL} = 0.3V_{CCD}$	–400	–	–	μ A
I_{IH}	HIGH-level input current	$V_{IH} = 0.7V_{CCD}$	–	–	20	μ A
V_I AND \bar{V}_I (REFERENCED TO AGND; see Tables 1 AND 2); $V_{ref} = V_{CCA} - 2$ V						
I_{IL}	LOW-level input current	$V_i = \bar{V}_i$	–	10	–	μ A
I_{IH}	HIGH-level input current	$V_i = \bar{V}_i$	–	10	–	μ A
Z_i	input impedance	$f_i = 4.43$ MHz	–	10	–	k Ω
C_i	input capacitance	$f_i = 4.43$ MHz	–	2	–	pF
$V_{ios(d)}$	input offset voltage in differential mode	$V_i = \bar{V}_i$; output code 2047 $V_{CCA} = 5$ V	tbf	2.5	tbf	V
		$V_{CCA} = 4.75$ V	tbf	2.25	tbf	V
		$V_{CCA} = 5.25$ V	tbf	2.75	tbf	V
$V_{ios(s)}$	input offset voltage in single mode	$V_i = V_{ios(s)}$; output code 2047 $V_{CCA} = 5$ V	tbf	2.5	tbf	V
		$V_{CCA} = 4.75$ V	tbf	2.25	tbf	V
		$V_{CCA} = 5.25$ V	tbf	2.75	tbf	V

12-bit high-speed Analog-to-Digital Converter (ADC)

TDA8767

SYMBOL	PARAMETER	CONDITIONS	MIN.	TYP.	MAX.	UNIT
Voltage controlled regulator input V_{ref} (referenced to V_{CCA})						
$V_{ref(FS)}$	full scale fixed voltage	$V_{CCA} = 5\text{ V}$	–	3.175	–	V
$V_{i(p-p)} - \bar{V}_{i(p-p)}$	input voltage amplitude (peak-to-peak value)	differential mode	–	2.0	–	V
		single mode; $\bar{V}_i = 2.5\text{ V}$	–	2.0	–	V
I_{ref}	input current at V_{ref}		–	10	–	μA
Outputs (referenced to DGND)						
DIGITAL OUTPUTS D11 TO D0 AND IR (REFERENCED TO DGND)						
V_{OL}	LOW-level output voltage	$I_{OL} = 2\text{ mA}$	0	–	0.5	V
V_{OH}	HIGH-level output voltage	$I_{OH} = -0.4\text{ mA}$	$V_{CCO} - 0.5$	–	V_{CCD}	V
I_o	output current in 3-state	$0.5\text{ V} < V_o < V_{CCO}$	-20	–	+20	μA
Switching characteristics						
CLOCK FREQUENCY f_{clk} (see Fig.3)						
$f_{clk(min)}$	minimum clock frequency	SH = HIGH	–	–	1	MHz
		SH = LOW	–	–	1	kHz
$f_{clk(max)}$	maximum clock frequency	TDA8767H/1	10	–	–	MHz
		TDA8767H/2	20	–	–	MHz
		TDA8767H/3	30	–	–	MHz
t_{CPH}	clock pulse width HIGH		8.5	–	–	ns
t_{CPL}	clock pulse width LOW		8.5	–	–	ns
Analog signal processing; 50% clock duty factor; $V_i - \bar{V}_i = 2.0\text{ V}$; $V_{ref} = V_{CCA} - 2\text{ V}$; see Table 1						
LINEARITY						
ILE	integral non-linearity	$f_{clk} = 4\text{ MHz}$; ramp input	–	± 3.0	± 4.0	LSB
DLE	differential non-linearity	$f_{clk} = 4\text{ MHz}$; ramp input; no missing codes	–	± 0.6	± 1	LSB
OFER	offset error	$V_{CCA} = V_{CCD} = V_{CCO} = 5\text{ V}$; $T_{amb} = 25\text{ }^\circ\text{C}$; $V_i = \bar{V}_i$; output code = 2047	tbf	–	tbf	LSB
GER	gain error amplitude; spread from device to device	$V_{CCA} = V_{CCD} = V_{CCO} = 5\text{ V}$; $T_{amb} = 25\text{ }^\circ\text{C}$; $V_i - \bar{V}_i = 2.0\text{ V}$	tbf	–	tbf	LSB
BANDWIDTH ($f_{clk} = 30\text{ MHz}$); note 1						
B	analog bandwidth	-1 dB	–	9	–	MHz
		-3 dB	–	18	–	MHz
t_{STLH}	analog input settling time LOW-to-HIGH transition	full scale square wave; note 3	–	tbf	–	ns
t_{STHL}	analog input settling time HIGH-to-LOW transition	full scale square wave; note 3	–	tbf	–	ns
HARMONICS						
THD	total harmonic distortion	$f_{clk} = 30\text{ MHz}$; $f_i = 4.43\text{ MHz}$; note 2	–	-64	–	dB

12-bit high-speed Analog-to-Digital Converter (ADC)

TDA8767

SYMBOL	PARAMETER	CONDITIONS	MIN.	TYP.	MAX.	UNIT
SIGNAL-TO-NOISE RATIO						
S/N	signal-to-noise ratio	without harmonics; $f_{\text{clk}} = 30 \text{ MHz}$; $f_i = 4.43 \text{ MHz}$	–	61	–	dB
Timing ($C_L = 15 \text{ pF}$); note 4; see Fig.3						
t_{ds}	sampling delay time		–	–	2	ns
t_{h}	output hold time		8	–	–	ns
t_{d}	output delay time	$V_{\text{CCO}} = 4.75 \text{ V}$	–	12	15	ns
		$V_{\text{CCO}} = 3.15 \text{ V}$		15	18	ns
3-state output delay times; see Fig.4						
t_{dZH}	enable HIGH		–	14	18	ns
t_{dZL}	enable LOW		–	16	20	ns
t_{dHZ}	disable HIGH		–	16	20	ns
t_{dLZ}	disable LOW		–	14	18	ns

Notes to the characteristics

- The –3 dB (or –1 dB) analog bandwidth is determined by the 3 dB (or 1 dB) reduction in the reconstructed output, the input being a full-scale sine wave.
- THD (total harmonic distortion) is obtained with the addition of the first five harmonics:

$$\text{THD} = 20 \log \frac{F}{\sqrt{(2\text{nd})^2 + (3\text{rd})^2 + (4\text{th})^2 + (5\text{th})^2 + (6\text{th})^2}}$$

F being the fundamental harmonic referenced at 0 dB for a full-scale sine wave input.

- The analog input settling time is the minimum time required for the input signal to be stabilized after a sharp full-scale input (square wave signal) in order to sample the signal and obtain correct output data (see Fig.5).
- Output data acquisition: the output data is available after the maximum delay of t_{d} .

12-bit high-speed Analog-to-Digital Converter (ADC)

TDA8767

Table 1 Output coding with differential inputs (typical values to AGND); $V_{I(p-p)} - \bar{V}_{I(p-p)} = 2.0 \text{ V}$; $V_{\text{ref}} = V_{\text{CCA}} - 2 \text{ V}$

CODE	V_I	\bar{V}_I	IR	BINARY OUTPUTS	TWO'S COMPLEMENT OUTPUTS
				D11 to D0	D11 to D0
underflow	<2.0	>3.0	0	0 0 0 0 0 0 0 0 0 0 0 0	1 0 0 0 0 0 0 0 0 0 0 0
0	2.0	3.0	1	0 0 0 0 0 0 0 0 0 0 0 0	1 0 0 0 0 0 0 0 0 0 0 0
1	–	–	1	0 0 0 0 0 0 0 0 0 0 0 1	1 0 0 0 0 0 0 0 0 0 0 1
↓	–	–	↓	↓	↓
2047	2.5	2.5	1	0 1 1 1 1 1 1 1 1 1 1 1	1 1 1 1 1 1 1 1 1 1 1 1
↓	–	–	↓	↓	↓
4094	–	–	1	1 1 1 1 1 1 1 1 1 1 1 0	0 1 1 1 1 1 1 1 1 1 1 0
4095	3.0	2.0	1	1 1 1 1 1 1 1 1 1 1 1 1	0 1 1 1 1 1 1 1 1 1 1 1
overflow	>3.0	<2.0	0	1 1 1 1 1 1 1 1 1 1 1 1	0 1 1 1 1 1 1 1 1 1 1 1

Table 2 Output coding with single input (typical values to AGND); $V_{\text{FS}} = 2.0 \text{ V (p-p)}$; $V_{\text{ref}} = V_{\text{CCA}} - 2 \text{ V}$

CODE	V_I	IR	BINARY OUTPUTS	TWO'S COMPLEMENT OUTPUTS
			D11 to D0	D11 to D0
underflow	<1.5	0	0 0 0 0 0 0 0 0 0 0 0 0	1 0 0 0 0 0 0 0 0 0 0 0
0	1.5	1	0 0 0 0 0 0 0 0 0 0 0 0	1 0 0 0 0 0 0 0 0 0 0 0
1	–	1	0 0 0 0 0 0 0 0 0 0 0 1	1 0 0 0 0 0 0 0 0 0 0 1
↓	–	↓	↓	↓
2047	2.5	1	0 1 1 1 1 1 1 1 1 1 1 1	1 1 1 1 1 1 1 1 1 1 1 1
↓	–	↓	↓	↓
4094	–	1	1 1 1 1 1 1 1 1 1 1 1 0	0 1 1 1 1 1 1 1 1 1 1 0
4095	3.5	1	1 1 1 1 1 1 1 1 1 1 1 1	0 1 1 1 1 1 1 1 1 1 1 1
overflow	>3.5	0	1 1 1 1 1 1 1 1 1 1 1 1	0 1 1 1 1 1 1 1 1 1 1 1

Table 3 Mode selection

TC	$\overline{\text{OE}}$	D0 to D11 and IR
0	0	binary; active
1	0	two's complement; active
X ⁽¹⁾	1	high impedance

Note

1. Where: X = don't care.

Table 4 Sample-and-hold selection

SH	SAMPLE-AND-HOLD
1	active
0	inactive; tracking mode

12-bit high-speed Analog-to-Digital Converter (ADC)

TDA8767

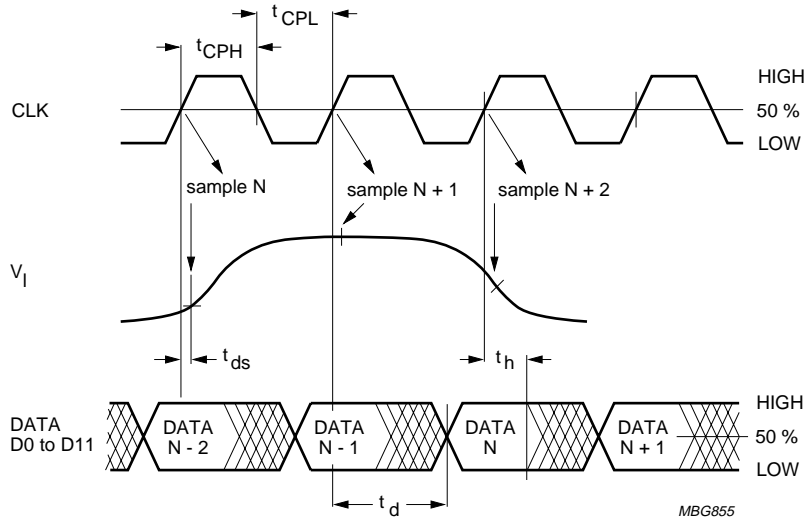
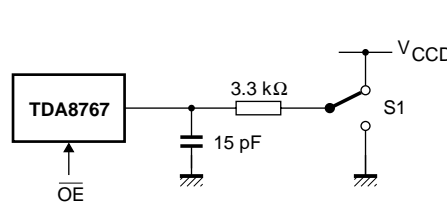
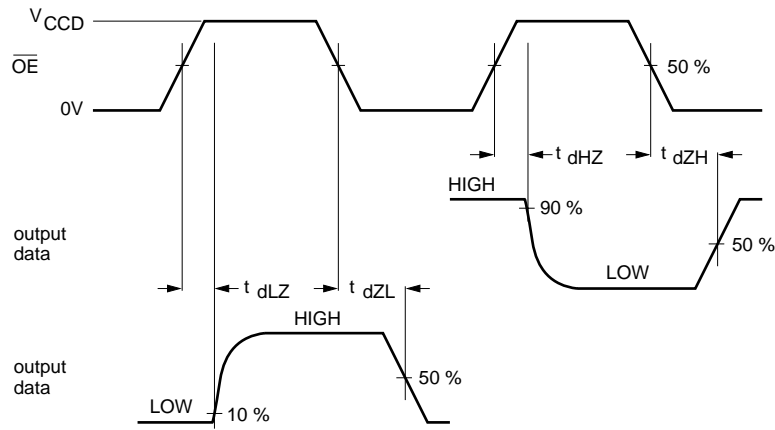

Fig.3 Timing diagram.



TEST	S1
t_{dLZ}	V_{CCD}
t_{dZL}	V_{CCD}
t_{dHZ}	DGND
t_{dZH}	DGND

$f_{OE} = 100 \text{ kHz}$.

Fig.4 Timing diagram and test conditions of 3-state output delay time.

12-bit high-speed Analog-to-Digital Converter (ADC)

TDA8767

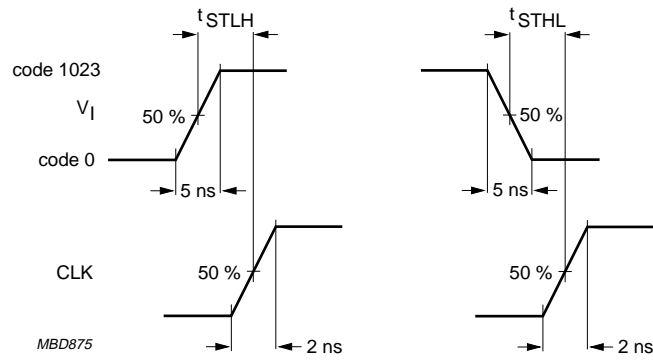
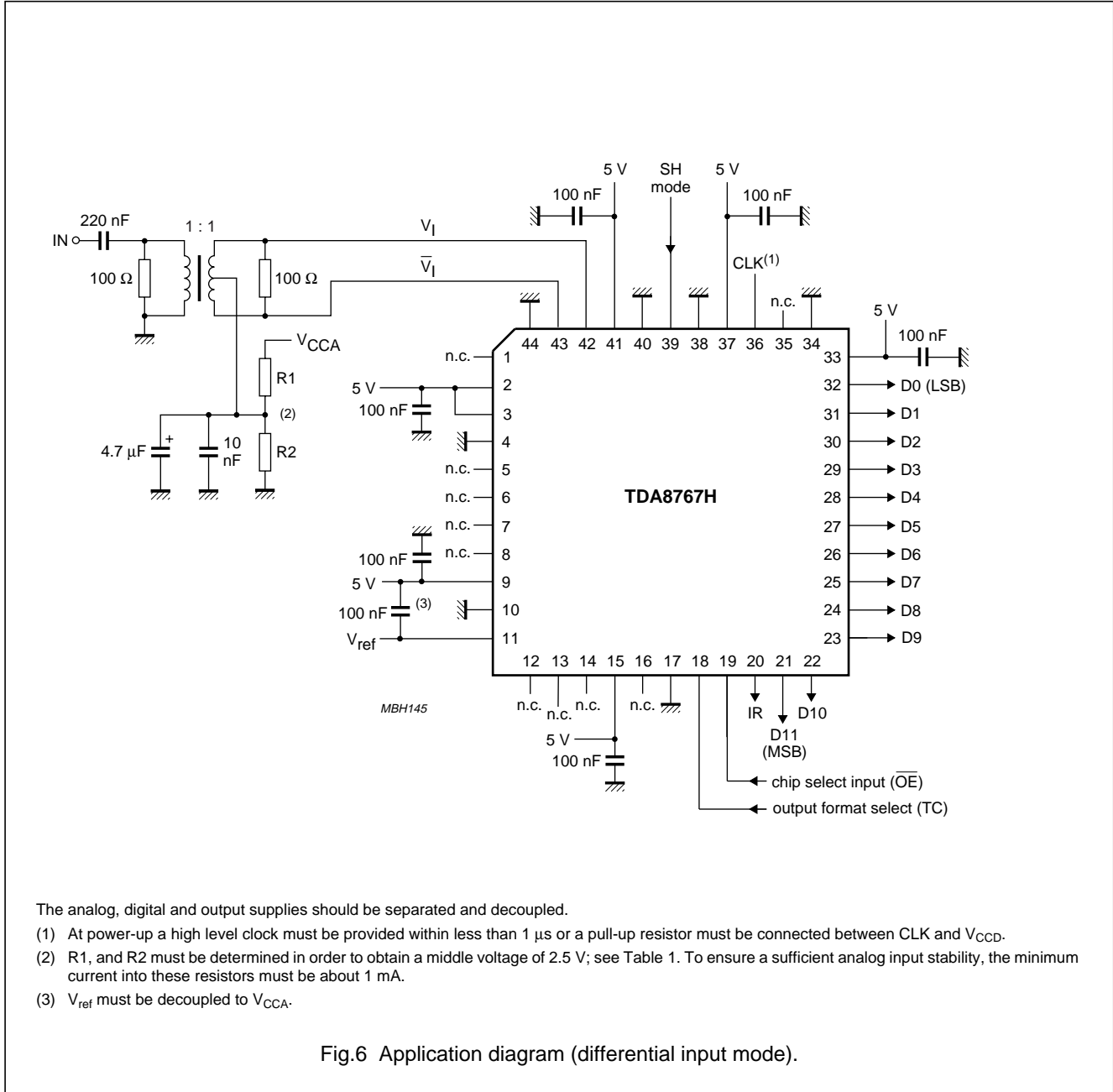

Fig.5 Analog input settling time diagram.

12-bit high-speed Analog-to-Digital Converter (ADC)

TDA8767

APPLICATION INFORMATION



The analog, digital and output supplies should be separated and decoupled.

- (1) At power-up a high level clock must be provided within less than 1 μs or a pull-up resistor must be connected between CLK and V_{CCD} .
- (2) R1, and R2 must be determined in order to obtain a middle voltage of 2.5 V; see Table 1. To ensure a sufficient analog input stability, the minimum current into these resistors must be about 1 mA.
- (3) V_{ref} must be decoupled to V_{CCA} .

Fig.6 Application diagram (differential input mode).

12-bit high-speed Analog-to-Digital Converter (ADC)

TDA8767

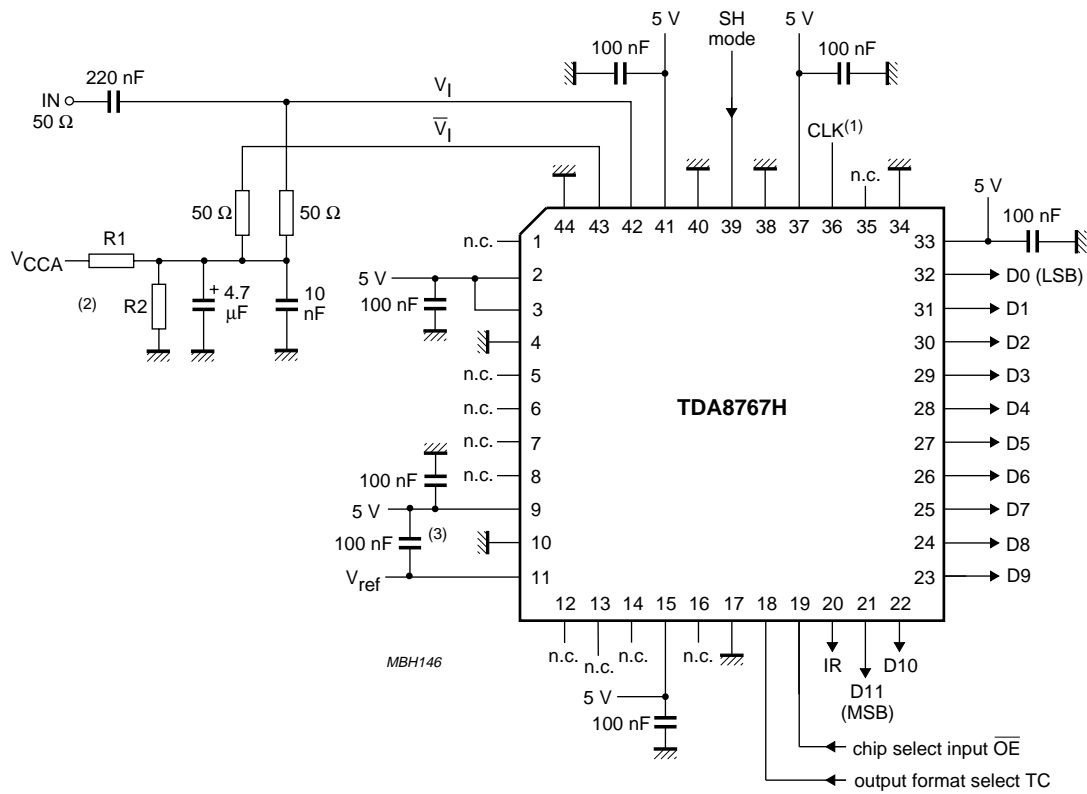

The analog, digital and output supplies should be separated and decoupled.

- (1) At power-up a high level clock must be provided within less than 1 μs or a pull-up resistor must be connected between CLK and V_{CCD}.
- (2) R1, and R2 must be determined in order to obtain a voltage of 2.5 V on V_I and V_I-bar; see Table 1. To ensure a sufficient analog input stability, the minimum current into these resistors must be about 1 mA.
- (3) V_{ref} must be decoupled to V_{CCA}.

Fig.7 Application diagram (single input mode).

12-bit high-speed Analog-to-Digital Converter (ADC)

TDA8767

PACKAGE OUTLINE

QFP44: plastic quad flat package; 44 leads (lead length 1.3 mm); body 10 x 10 x 1.75 mm

SOT307-2

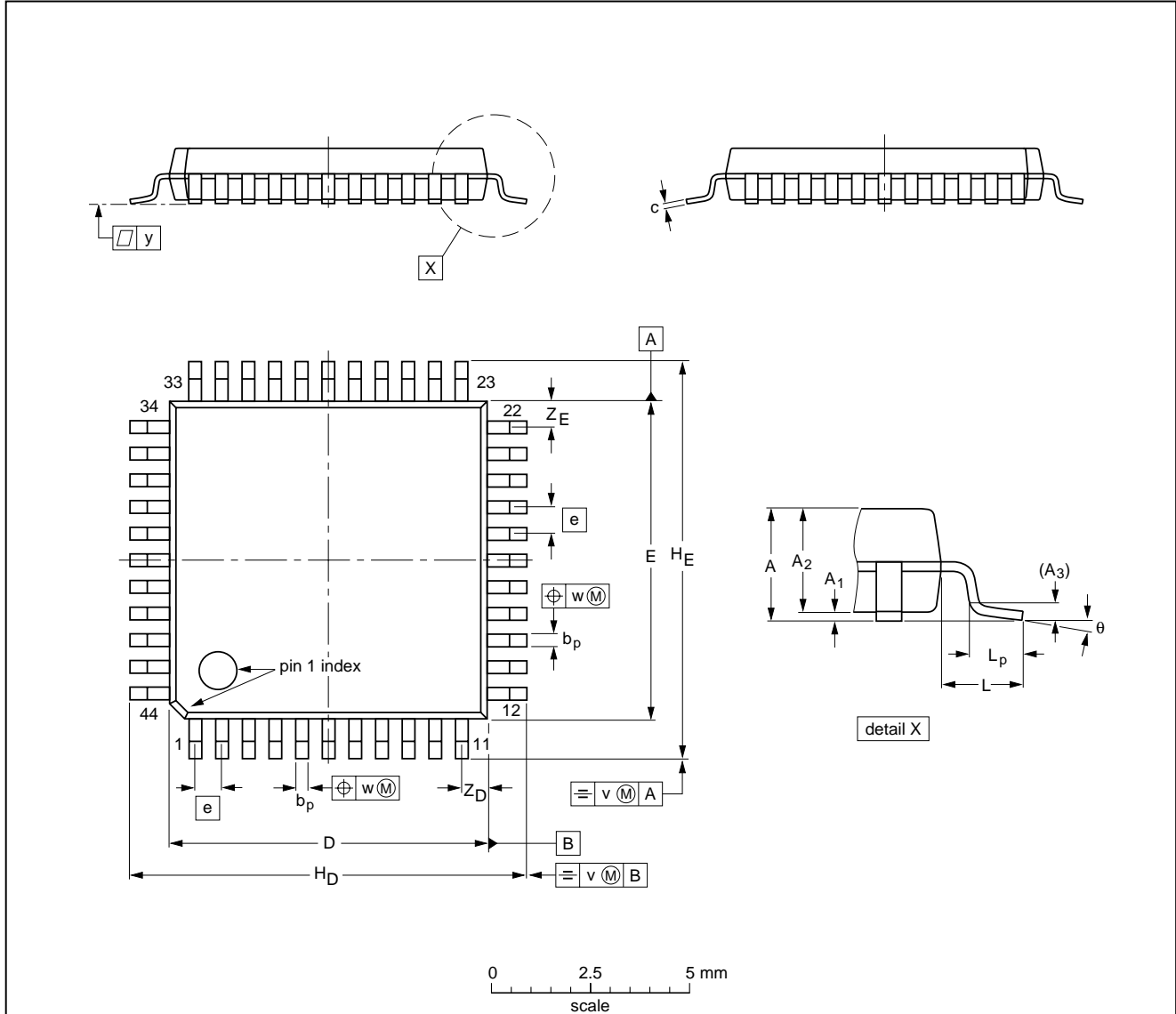

DIMENSIONS (mm are the original dimensions)

UNIT	A max.	A ₁	A ₂	A ₃	b _p	c	D ⁽¹⁾	E ⁽¹⁾	e	H _D	H _E	L	L _p	v	w	y	Z _D ⁽¹⁾	Z _E ⁽¹⁾	θ
mm	2.10	0.25 0.05	1.85 1.65	0.25	0.40 0.20	0.25 0.14	10.1 9.9	10.1 9.9	0.8	12.9 12.3	12.9 12.3	1.3	0.95 0.55	0.15	0.15	0.1	1.2 0.8	1.2 0.8	10° 0°

Note

1. Plastic or metal protrusions of 0.25 mm maximum per side are not included.

OUTLINE VERSION	REFERENCES				EUROPEAN PROJECTION	ISSUE DATE
	IEC	JEDEC	EIAJ			
SOT307-2						95-02-04 97-08-01

12-bit high-speed Analog-to-Digital Converter (ADC)

TDA8767

SOLDERING

Introduction to soldering surface mount packages

This text gives a very brief insight to a complex technology. A more in-depth account of soldering ICs can be found in our "Data Handbook IC26; Integrated Circuit Packages" (document order number 9398 652 90011).

There is no soldering method that is ideal for all surface mount IC packages. Wave soldering is not always suitable for surface mount ICs, or for printed-circuit boards with high population densities. In these situations reflow soldering is often used.

Reflow soldering

Reflow soldering requires solder paste (a suspension of fine solder particles, flux and binding agent) to be applied to the printed-circuit board by screen printing, stencilling or pressure-syringe dispensing before package placement.

Several methods exist for reflowing; for example, infrared/convection heating in a conveyor type oven. Throughput times (preheating, soldering and cooling) vary between 100 and 200 seconds depending on heating method.

Typical reflow peak temperatures range from 215 to 250 °C. The top-surface temperature of the packages should preferably be kept below 230 °C.

Wave soldering

Conventional single wave soldering is not recommended for surface mount devices (SMDs) or printed-circuit boards with a high component density, as solder bridging and non-wetting can present major problems.

To overcome these problems the double-wave soldering method was specifically developed.

If wave soldering is used the following conditions must be observed for optimal results:

- Use a double-wave soldering method comprising a turbulent wave with high upward pressure followed by a smooth laminar wave.
 - For packages with leads on two sides and a pitch (e):
 - larger than or equal to 1.27 mm, the footprint longitudinal axis is **preferred** to be parallel to the transport direction of the printed-circuit board;
 - smaller than 1.27 mm, the footprint longitudinal axis **must** be parallel to the transport direction of the printed-circuit board.
- The footprint must incorporate solder thieves at the downstream end.
- For packages with leads on four sides, the footprint must be placed at a 45° angle to the transport direction of the printed-circuit board. The footprint must incorporate solder thieves downstream and at the side corners.

During placement and before soldering, the package must be fixed with a droplet of adhesive. The adhesive can be applied by screen printing, pin transfer or syringe dispensing. The package can be soldered after the adhesive is cured.

Typical dwell time is 4 seconds at 250 °C.

A mildly-activated flux will eliminate the need for removal of corrosive residues in most applications.

Manual soldering

Fix the component by first soldering two diagonally-opposite end leads. Use a low voltage (24 V or less) soldering iron applied to the flat part of the lead. Contact time must be limited to 10 seconds at up to 300 °C.

When using a dedicated tool, all other leads can be soldered in one operation within 2 to 5 seconds between 270 and 320 °C.

12-bit high-speed Analog-to-Digital Converter (ADC)

TDA8767

Suitability of surface mount IC packages for wave and reflow soldering methods

PACKAGE	SOLDERING METHOD	
	WAVE	REFLOW ⁽¹⁾
BGA, SQFP	not suitable	suitable
HLQFP, HSQFP, HSOP, HTSSOP, SMS	not suitable ⁽²⁾	suitable
PLCC ⁽³⁾ , SO, SOJ	suitable	suitable
LQFP, QFP, TQFP	not recommended ⁽³⁾⁽⁴⁾	suitable
SSOP, TSSOP, VSO	not recommended ⁽⁵⁾	suitable

Notes

- All surface mount (SMD) packages are moisture sensitive. Depending upon the moisture content, the maximum temperature (with respect to time) and body size of the package, there is a risk that internal or external package cracks may occur due to vaporization of the moisture in them (the so called popcorn effect). For details, refer to the Drypack information in the "Data Handbook IC26; Integrated Circuit Packages; Section: Packing Methods".
- These packages are not suitable for wave soldering as a solder joint between the printed-circuit board and heatsink (at bottom version) can not be achieved, and as solder may stick to the heatsink (on top version).
- If wave soldering is considered, then the package must be placed at a 45° angle to the solder wave direction. The package footprint must incorporate solder thieves downstream and at the side corners.
- Wave soldering is only suitable for LQFP, TQFP and QFP packages with a pitch (e) equal to or larger than 0.8 mm; it is definitely not suitable for packages with a pitch (e) equal to or smaller than 0.65 mm.
- Wave soldering is only suitable for SSOP and TSSOP packages with a pitch (e) equal to or larger than 0.65 mm; it is definitely not suitable for packages with a pitch (e) equal to or smaller than 0.5 mm.

DEFINITIONS

Data sheet status	
Objective specification	This data sheet contains target or goal specifications for product development.
Preliminary specification	This data sheet contains preliminary data; supplementary data may be published later.
Product specification	This data sheet contains final product specifications.
Limiting values	
Limiting values given are in accordance with the Absolute Maximum Rating System (IEC 134). Stress above one or more of the limiting values may cause permanent damage to the device. These are stress ratings only and operation of the device at these or at any other conditions above those given in the Characteristics sections of the specification is not implied. Exposure to limiting values for extended periods may affect device reliability.	
Application information	
Where application information is given, it is advisory and does not form part of the specification.	

LIFE SUPPORT APPLICATIONS

These products are not designed for use in life support appliances, devices, or systems where malfunction of these products can reasonably be expected to result in personal injury. Philips customers using or selling these products for use in such applications do so at their own risk and agree to fully indemnify Philips for any damages resulting from such improper use or sale.

12-bit high-speed Analog-to-Digital
Converter (ADC)

TDA8767

NOTES

12-bit high-speed Analog-to-Digital
Converter (ADC)

TDA8767

NOTES

Philips Semiconductors – a worldwide company

Argentina: see South America

Australia: 34 Waterloo Road, NORTH RYDE, NSW 2113, Tel. +61 2 9805 4455, Fax. +61 2 9805 4466

Austria: Computerstr. 6, A-1101 WIEN, P.O. Box 213, Tel. +43 1 60 101 1248, Fax. +43 1 60 101 1210

Belarus: Hotel Minsk Business Center, Bld. 3, r. 1211, Volodarski Str. 6, 220050 MINSK, Tel. +375 172 20 0733, Fax. +375 172 20 0773

Belgium: see The Netherlands

Brazil: see South America

Bulgaria: Philips Bulgaria Ltd., Energoproject, 15th floor, 51 James Bourchier Blvd., 1407 SOFIA, Tel. +359 2 68 9211, Fax. +359 2 68 9102

Canada: PHILIPS SEMICONDUCTORS/COMPONENTS, Tel. +1 800 234 7381, Fax. +1 800 943 0087

China/Hong Kong: 501 Hong Kong Industrial Technology Centre, 72 Tat Chee Avenue, Kowloon Tong, HONG KONG, Tel. +852 2319 7888, Fax. +852 2319 7700

Colombia: see South America

Czech Republic: see Austria

Denmark: Sydhavnsgade 23, 1780 COPENHAGEN V, Tel. +45 33 29 3333, Fax. +45 33 29 3905

Finland: Sinikalliontie 3, FIN-02630 ESPOO, Tel. +358 9 615 800, Fax. +358 9 6158 0920

France: 51 Rue Carnot, BP317, 92156 SURESNES Cedex, Tel. +33 1 4099 6161, Fax. +33 1 4099 6427

Germany: Hammerbrookstraße 69, D-20097 HAMBURG, Tel. +49 40 2353 60, Fax. +49 40 2353 6300

Greece: No. 15, 25th March Street, GR 17778 TAVROS/ATHENS, Tel. +30 1 489 4339/4239, Fax. +30 1 481 4240

Hungary: see Austria

India: Philips INDIA Ltd, Band Box Building, 2nd floor, 254-D, Dr. Annie Besant Road, Worli, MUMBAI 400 025, Tel. +91 22 493 8541, Fax. +91 22 493 0966

Indonesia: PT Philips Development Corporation, Semiconductors Division, Gedung Philips, Jl. Buncit Raya Kav.99-100, JAKARTA 12510, Tel. +62 21 794 0040 ext. 2501, Fax. +62 21 794 0080

Ireland: Newstead, Clonskeagh, DUBLIN 14, Tel. +353 1 7640 000, Fax. +353 1 7640 200

Israel: RAPAC Electronics, 7 Kehilat Saloniki St, PO Box 18053, TEL AVIV 61180, Tel. +972 3 645 0444, Fax. +972 3 649 1007

Italy: PHILIPS SEMICONDUCTORS, Piazza IV Novembre 3, 20124 MILANO, Tel. +39 2 6752 2531, Fax. +39 2 6752 2557

Japan: Philips Bldg 13-37, Kohnan 2-chome, Minato-ku, TOKYO 108-8507, Tel. +81 3 3740 5130, Fax. +81 3 3740 5077

Korea: Philips House, 260-199 Itaewon-dong, Yongsan-ku, SEOUL, Tel. +82 2 709 1412, Fax. +82 2 709 1415

Malaysia: No. 76 Jalan Universiti, 46200 PETALING JAYA, SELANGOR, Tel. +60 3 750 5214, Fax. +60 3 757 4880

Mexico: 5900 Gateway East, Suite 200, EL PASO, TEXAS 79905, Tel. +9-5 800 234 7381, Fax +9-5 800 943 0087

Middle East: see Italy

Netherlands: Postbus 90050, 5600 PB EINDHOVEN, Bldg. VB, Tel. +31 40 27 82785, Fax. +31 40 27 88399

New Zealand: 2 Wagener Place, C.P.O. Box 1041, AUCKLAND, Tel. +64 9 849 4160, Fax. +64 9 849 7811

Norway: Box 1, Manglerud 0612, OSLO, Tel. +47 22 74 8000, Fax. +47 22 74 8341

Pakistan: see Singapore

Philippines: Philips Semiconductors Philippines Inc., 106 Valero St. Salcedo Village, P.O. Box 2108 MCC, MAKATI, Metro MANILA, Tel. +63 2 816 6380, Fax. +63 2 817 3474

Poland: Ul. Lukiska 10, PL 04-123 WARSZAWA, Tel. +48 22 612 2831, Fax. +48 22 612 2327

Portugal: see Spain

Romania: see Italy

Russia: Philips Russia, Ul. Usatcheva 35A, 119048 MOSCOW, Tel. +7 095 755 6918, Fax. +7 095 755 6919

Singapore: Lorong 1, Toa Payoh, SINGAPORE 319762, Tel. +65 350 2538, Fax. +65 251 6500

Slovakia: see Austria

Slovenia: see Italy

South Africa: S.A. PHILIPS Pty Ltd., 195-215 Main Road Martindale, 2092 JOHANNESBURG, P.O. Box 7430 Johannesburg 2000, Tel. +27 11 470 5911, Fax. +27 11 470 5494

South America: Al. Vicente Pinzon, 173, 6th floor, 04547-130 SÃO PAULO, SP, Brazil, Tel. +55 11 821 2333, Fax. +55 11 821 2382

Spain: Balmes 22, 08007 BARCELONA, Tel. +34 93 301 6312, Fax. +34 93 301 4107

Sweden: Kottbygatan 7, Akalla, S-16485 STOCKHOLM, Tel. +46 8 5985 2000, Fax. +46 8 5985 2745

Switzerland: Allmendstrasse 140, CH-8027 ZÜRICH, Tel. +41 1 488 2741 Fax. +41 1 488 3263

Taiwan: Philips Semiconductors, 6F, No. 96, Chien Kuo N. Rd., Sec. 1, TAIPEI, Taiwan Tel. +886 2 2134 2886, Fax. +886 2 2134 2874

Thailand: PHILIPS ELECTRONICS (THAILAND) Ltd., 209/2 Sanpavuth-Bangna Road Prakanong, BANGKOK 10260, Tel. +66 2 745 4090, Fax. +66 2 398 0793

Turkey: Talatpasa Cad. No. 5, 80640 GÜLTEPE/ISTANBUL, Tel. +90 212 279 2770, Fax. +90 212 282 6707

Ukraine: PHILIPS UKRAINE, 4 Patrice Lumumba str., Building B, Floor 7, 252042 KIEV, Tel. +380 44 264 2776, Fax. +380 44 268 0461

United Kingdom: Philips Semiconductors Ltd., 276 Bath Road, Hayes, MIDDLESEX UB3 5BX, Tel. +44 181 730 5000, Fax. +44 181 754 8421

United States: 811 East Arques Avenue, SUNNYVALE, CA 94088-3409, Tel. +1 800 234 7381, Fax. +1 800 943 0087

Uruguay: see South America

Vietnam: see Singapore

Yugoslavia: PHILIPS, Trg N. Pasica 5/v, 11000 BEOGRAD, Tel. +381 11 62 5344, Fax. +381 11 63 5777

For all other countries apply to: Philips Semiconductors, International Marketing & Sales Communications, Building BE-p, P.O. Box 218, 5600 MD EINDHOVEN, The Netherlands, Fax. +31 40 27 24825

Internet: <http://www.semiconductors.philips.com>

© Philips Electronics N.V. 1999

SCA62

All rights are reserved. Reproduction in whole or in part is prohibited without the prior written consent of the copyright owner.

The information presented in this document does not form part of any quotation or contract, is believed to be accurate and reliable and may be changed without notice. No liability will be accepted by the publisher for any consequence of its use. Publication thereof does not convey nor imply any license under patent- or other industrial or intellectual property rights.

Printed in The Netherlands

545004/750/03/pp20

Date of release: 1999 Feb 16

Document order number: 9397 750 04713

Let's make things better.

**Philips
Semiconductors**



PHILIPS