

# DATA SHEET

**TZA3031AHL; TZA3031BHL;  
TZA3031U**  
SDH/SONET STM1/OC3 laser  
drivers

Product specification  
Supersedes data of 1999 Aug 24  
File under Integrated Circuits, IC19

2000 Feb 22

**SDH/SONET STM1/OC3 laser drivers****TZA3031AHL; TZA3031BHL;  
TZA3031U****FEATURES**

- 155 Mb/s data input, both Current Mode Logic (CML) and Positive Emitter Coupled Logic (PECL) compatible; maximum 800 mV (p-p)
- Adaptive laser output control with dual loop, stabilizing optical 1 and 0 levels
- Optional external control of laser modulation and biasing currents (non-adaptive)
- Automatic laser shutdown
- Few external components required
- Rise and fall times of 120 ps (typical value)
- Jitter <50 mUI (p-p)
- RF output current sinking capability of 60 mA
- Bias current sinking capability of 90 mA
- Power dissipation of 430 mW (typical value)
- Low cost LQFP32 5 × 5 plastic package
- Single 5 V power supply.

**TZA3031AHL**

- Laser alarm output for signalling extremely low and high bias current conditions.

**TZA3031BHL**

- Extra STM1 155 Mb/s loop mode input; both CML and PECL compatible.

**TZA3031U**

- Bare die version with combined bias alarm and loop mode functionality.

**APPLICATIONS**

- SDH/SONET STM1/OC3 optical transmission systems
- SDH/SONET STM1/OC3 optical laser modules.

**GENERAL DESCRIPTION**

The TZA3031AHL, TZA3031BHL and TZA3031U are fully integrated laser drivers for STM1/OC3 (155 Mb/s) systems, incorporating the RF path between the data multiplexer and the laser diode. Since the dual loop bias and modulation control circuits are integrated on the IC, the external component count is low. Only decoupling capacitors and adjustment resistors are required.

The TZA3031AHL features an alarm function for signalling extreme bias current conditions. The alarm low and high threshold levels can be adjusted to suit the application using only a resistor or a current Digital-to-Analog Converter (DAC).

The TZA3031BHL is provided with an additional RF data input to allow remote system testing (loop mode).

The TZA3031U is a bare die version for use in compact laser module designs. The die contains 40 pads and features the combined functionality of the TZA3031AHL and the TZA3031BHL.

**ORDERING INFORMATION**

TYPE NUMBER	PACKAGE		
	NAME	DESCRIPTION	VERSION
TZA3031AHL	LQFP32	plastic low profile quad flat package; 32 leads; body 5 × 5 × 1.4 mm	SOT401-1
TZA3031BHL			
TZA3031U	–	bare die; 2000 × 2000 × 380 μm	–

SDH/SONET STM1/OC3 laser drivers

TZA3031AHL; TZA3031BHL;  
TZA3031U

BLOCK DIAGRAM

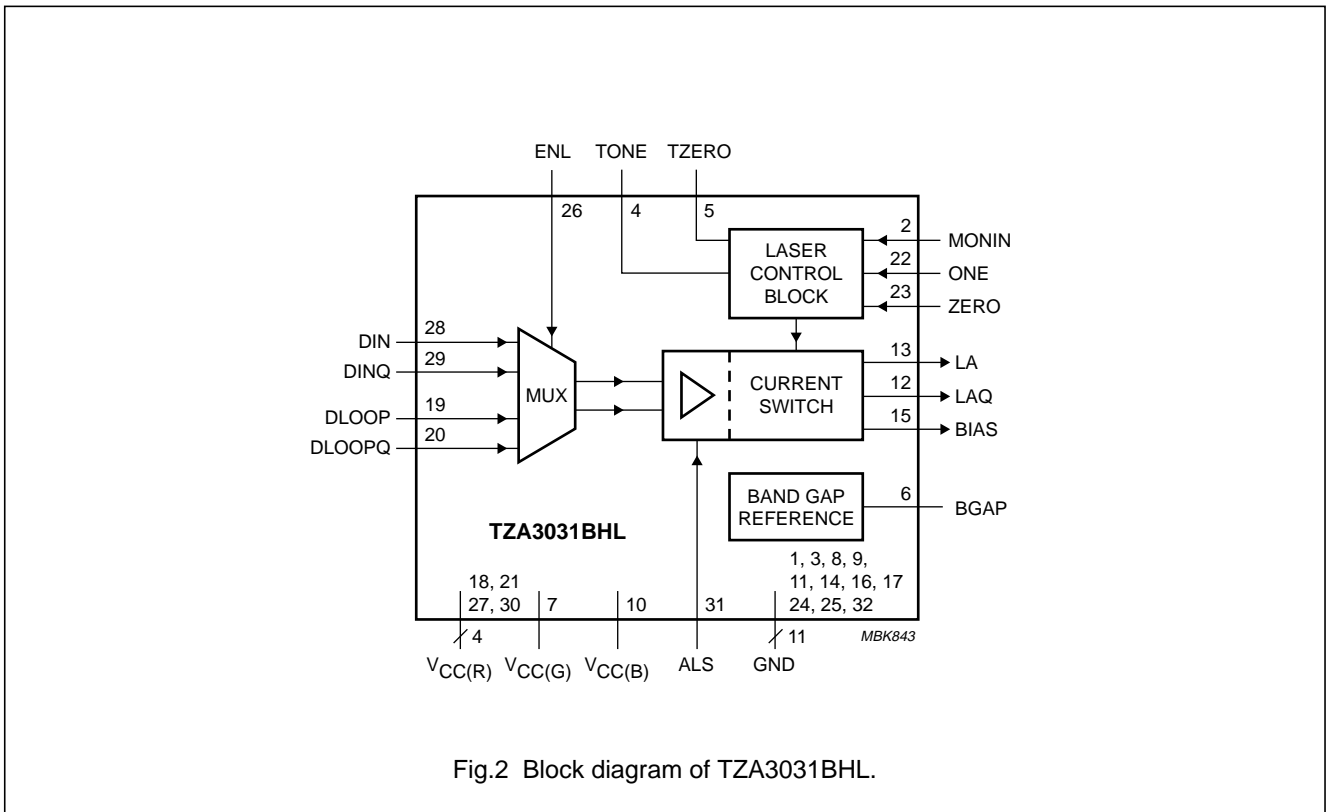
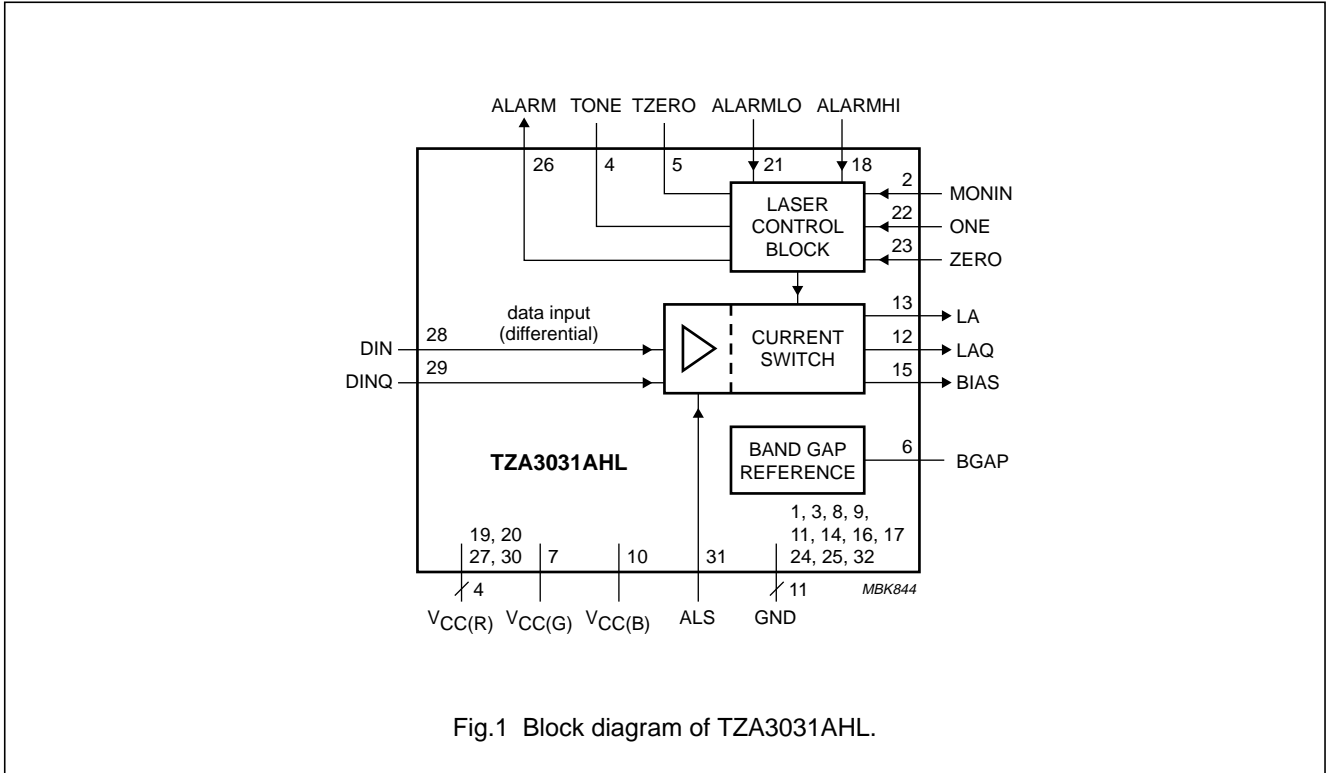

## SDH/SONET STM1/OC3 laser drivers

TZA3031AHL; TZA3031BHL;  
TZA3031U

## PINNING

SYMBOL	PIN		PAD	DESCRIPTION
	TZA3031AHL	TZA3031BHL	TZA3031U	
GND	1	1	1	ground
MONIN	2	2	2	monitor photodiode current input
GND	3	3	3	ground
IGM	–	–	4	not connected
TONE	4	4	5	connection for external capacitor used for setting optical 1 control loop time constant (optional)
TZERO	5	5	6	connection for external capacitor used for setting optical 0 control loop time constant (optional)
BGAP	6	6	7	connection for external band gap decoupling capacitor
V <sub>CC(G)</sub>	7	7	8	supply voltage (green domain); note 1
V <sub>CC(G)</sub>	–	–	9	supply voltage (green domain); note 1
GND	8	8	10	ground
GND	9	9	11	ground
V <sub>CC(B)</sub>	10	10	12	supply voltage (blue domain); note 2
V <sub>CC(B)</sub>	–	–	13	supply voltage (blue domain); note 2
GND	11	11	14	ground
LAQ	12	12	15	laser modulation output inverted
LA	13	13	16	laser modulation output
GND	14	14	17	ground
BIAS	15	15	18	laser bias current output
GND	16	16	19	ground
GND	17	17	20	ground
GND	–	–	21	ground
ALARMHI	18	–	22	maximum bias current alarm reference level input
V <sub>CC(R)</sub>	–	18	23	supply voltage (red domain); note 3
V <sub>CC(R)</sub>	19	–	–	supply voltage (red domain); note 3
DLOOP	–	19	24	loop mode data input
V <sub>CC(R)</sub>	20	–	–	supply voltage (red domain); note 3
DLOOPQ	–	20	25	loop mode data input inverted
V <sub>CC(R)</sub>	–	–	26	supply voltage (red domain); note 3
ALARMLO	21	–	27	minimum bias current alarm reference level input
V <sub>CC(R)</sub>	–	21	–	supply voltage (red domain); note 3
ONE	22	22	28	optical 1 reference level input
ZERO	23	23	29	optical 0 reference level input
GND	24	24	30	ground
GND	25	25	31	ground
ALARM	26	–	32	alarm output
ENL	–	26	33	loop mode enable input
V <sub>CC(R)</sub>	27	27	34	supply voltage (red domain); note 3

SDH/SONET STM1/OC3 laser drivers

TZA3031AHL; TZA3031BHL;  
TZA3031U

SYMBOL	PIN		PAD	DESCRIPTION
	TZA3031AHL	TZA3031BHL	TZA3031U	
DIN	28	28	35	data input
DINQ	29	29	36	data input inverted
V <sub>CC(R)</sub>	30	30	37	supply voltage (red domain); note 3
ALS	31	31	38	automatic laser shutdown input
GND	32	32	39	ground
GND	–	–	40	ground

Notes

1. Supply voltage for the Monitor PhotoDiode (MPD) input current.
2. Supply voltage for the laser modulation outputs (LA, LAQ).
3. Supply voltage for the data inputs (DIN, DINQ), optical 1 and 0 reference level inputs (ONE, ZERO), and the bias current alarm reference level inputs (ALARMHI, ALARMLO).

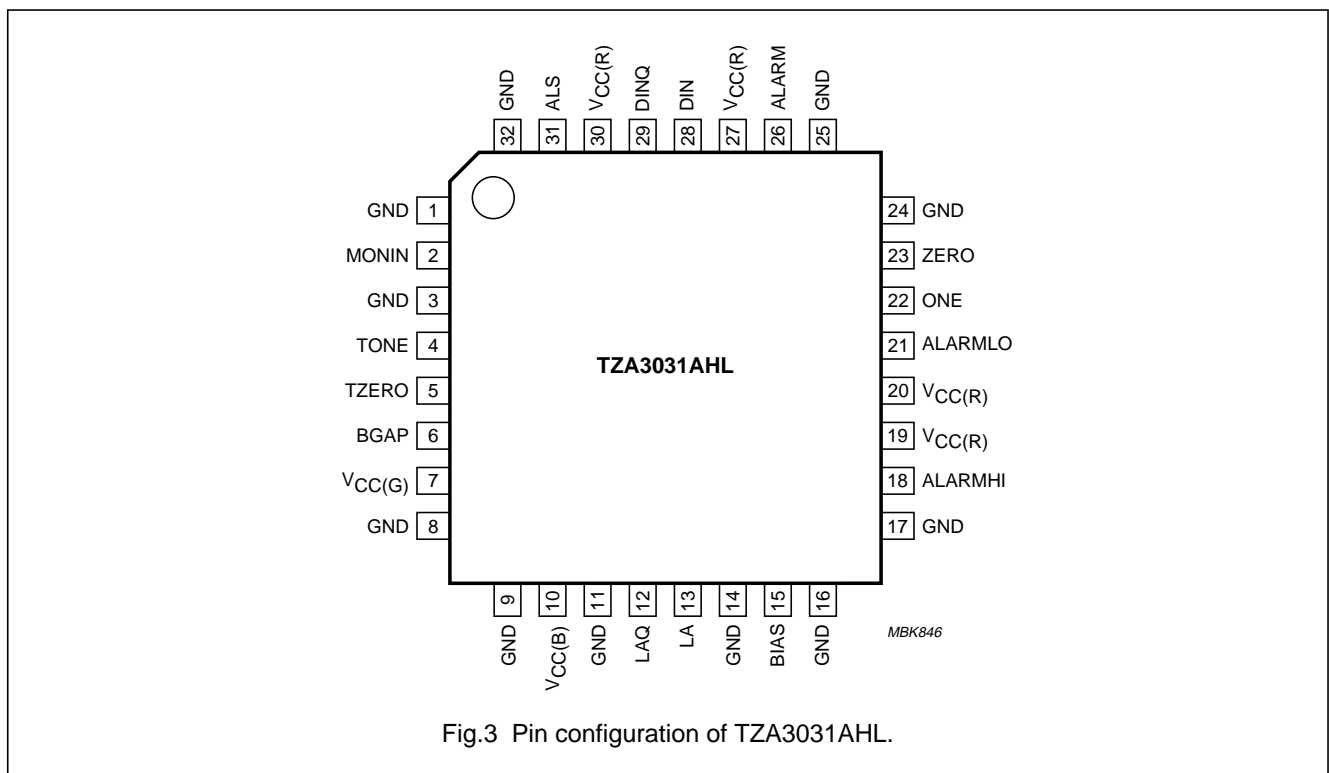

Fig.3 Pin configuration of TZA3031AHL.

SDH/SONET STM1/OC3 laser drivers

TZA3031AHL; TZA3031BHL;  
TZA3031U

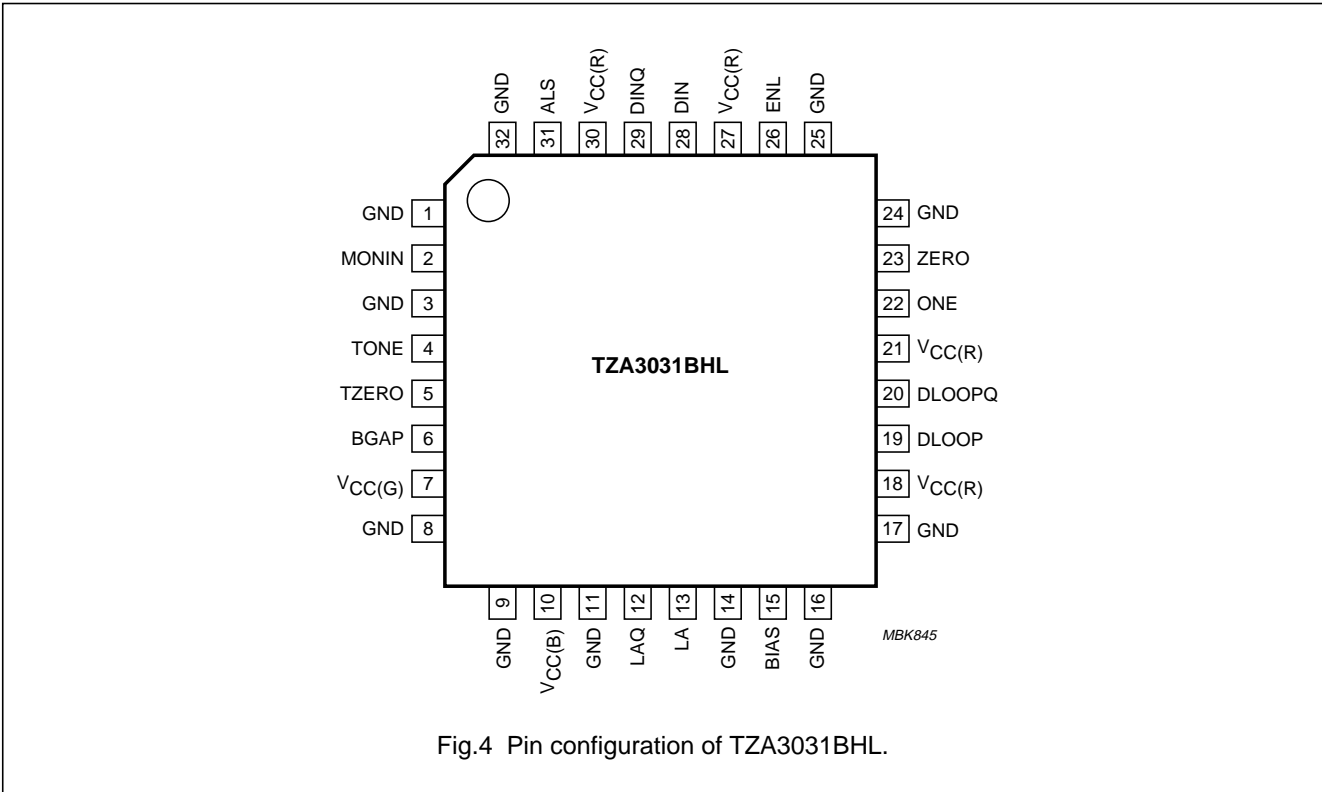

Fig.4 Pin configuration of TZA3031BHL.

**FUNCTIONAL DESCRIPTION**

The TZA3031AHL, TZA3031BHL and TZA3031U laser drivers accept a 155 Mbits/s STM1 Non-Return to Zero (NRZ) input data stream, and generate an output signal with sufficient current to drive a solid state Fabry Perot (FP) or Distributed FeedBack (DFB) laser. They also contain dual loop control circuitry for stabilizing the true laser optical power levels representing logic 1 and logic 0.

The input buffers present a high impedance to the data stream on the differential inputs (pins DIN and DINQ); see Fig.5. The input signal can be at a CML level of approximately 200 mV (p-p) below the supply voltage, or at a PECL level up to 800 mV (p-p). The inputs can be configured to accept CML signals by connecting pins DIN and DINQ to  $V_{CC(R)}$  via external 50  $\Omega$  pull-up resistors. If PECL compatibility is required, the usual Thevenin termination can be applied.

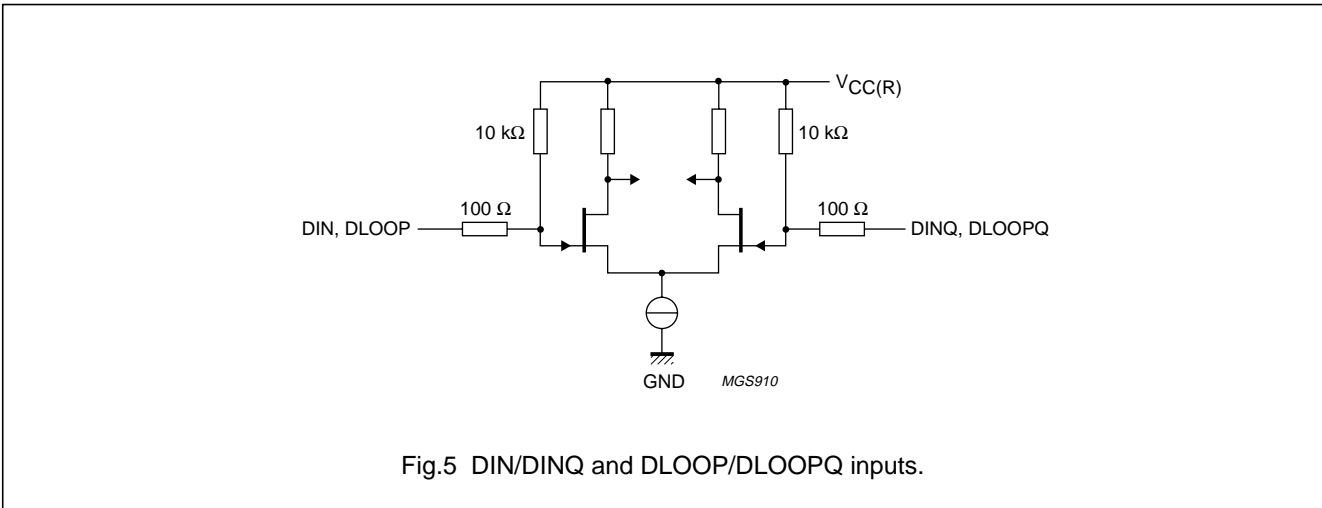

Fig.5 DIN/DINQ and DLOOP/DLOOPQ inputs.

SDH/SONET STM1/OC3 laser drivers

TZA3031AHL; TZA3031BHL;  
TZA3031U

For ECL signals (negative and referenced to ground), the inputs should be AC-coupled to the signal source. If AC-coupling is applied, a constant input signal (either LOW or HIGH) will cause the device to be in an undefined state. To avoid this, it is recommended to apply a slight offset to the input stage. The applied offset must be higher than the specified value in Chapter "Characteristics", but much lower than the applied input voltage swing.

The RF path is fully differential and contains a differential preamplifier and a main amplifier. The main amplifier is able to operate at the large peak currents required at the output laser driver stage and is insensitive to supply voltage variations. The output signal from the main amplifier drives a current switch which supplies a guaranteed maximum modulation current of 60 mA to pins LA and LAQ (see Fig.6). The BIAS pin outputs a guaranteed maximum DC bias current of up to 90 mA for adjusting the optical laser output to a level above its light emitting threshold (see Fig.7).

Automatic laser control

A laser with a Monitor PhotoDiode (MPD) is required for the laser control circuit (see application diagrams Figs 18 and 19).

The MPD current is proportional to the laser emission and is applied to pin MONIN. The MPD current range is 100 to 1000  $\mu$ A (p-p). The input buffer is optimized to cope with an MPD capacitance of up to 50 pF. To prevent the input buffer from oscillating if the MPD capacitance is low, the capacitance should be increased to the minimum value specified in Chapter "Characteristics", by connecting a capacitor between pin MONIN and  $V_{CC(G)}$ .

DC reference currents are applied to pins ONE and ZERO to set the MPD reference levels for laser HIGH and laser LOW respectively. This is adequately achieved by using resistors to connect  $V_{CC(R)}$  to pins ONE and ZERO (see Fig.8), however, current DACs can also be used. The voltages on pins ONE and ZERO are held at a constant level of 1.5 V below  $V_{CC(R)}$ . The reference current applied to pin ONE is internally multiplied by 16 and the reference current flowing into pin ZERO is internally multiplied by 4. The accuracy of the  $V_{CC(R)} - 1.5$  V voltage at pins ONE and ZERO is described in Section "Accuracy of voltage on inputs: ONE, ZERO, ALARMLO, ALARMHI".

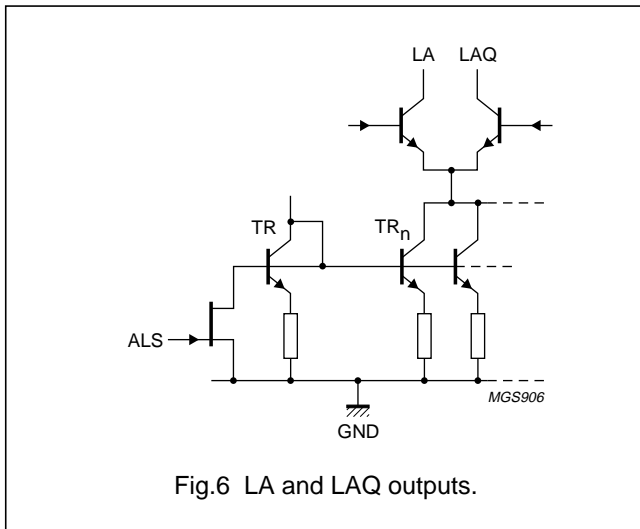

Fig.6 LA and LAQ outputs.

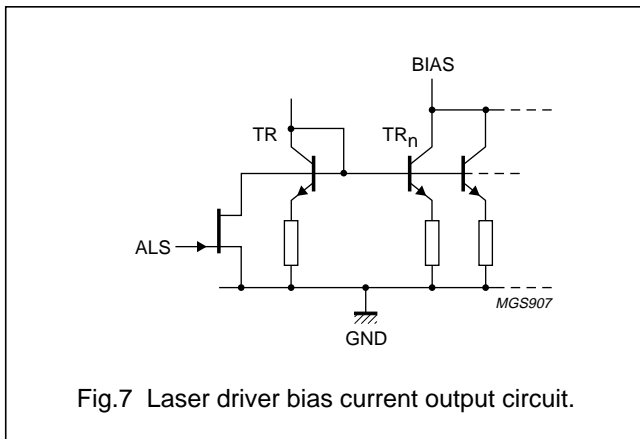

Fig.7 Laser driver bias current output circuit.

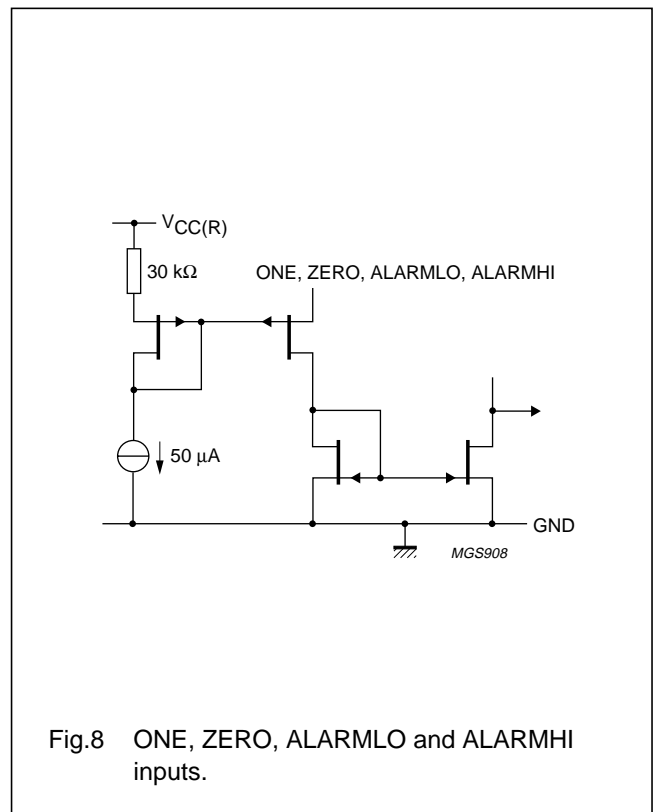

Fig.8 ONE, ZERO, ALARMLO and ALARMHI inputs.

## SDH/SONET STM1/OC3 laser drivers

TZA3031AHL; TZA3031BHL;  
TZA3031U

The reference current and the resistor for the optical 1 modulation current control loop is calculated using the following formulae:

$$I_{\text{ref(ONE)}} = \frac{1}{16} \times I_{\text{MPD(ONE)}} \quad [\text{A}] \quad (1)$$

$$R_{\text{ONE}} = \frac{1.5}{I_{\text{ONE}}} = \frac{24}{I_{\text{MPD(ONE)}}} \quad [\Omega] \quad (2)$$

The reference current and resistor for the optical 0 bias current control loop is calculated using the following formulae:

$$I_{\text{ref(ZERO)}} = \frac{1}{4} \times I_{\text{MPD(ZERO)}} \quad [\text{A}] \quad (3)$$

$$R_{\text{ZERO}} = \frac{1.5}{I_{\text{ZERO}}} = \frac{6}{I_{\text{MPD(ZERO)}}} \quad [\Omega] \quad (4)$$

In these formulae,  $I_{\text{MPD(ONE)}}$  and  $I_{\text{MPD(ZERO)}}$  represent the MPD current during an optical 1 and an optical 0 period, respectively.

## EXAMPLE

A laser operates at optical output power levels of 0.3 mW for laser HIGH and 0.03 mW for laser LOW (extinction ratio of 10 dB). Suppose the corresponding MPD currents for this particular laser are 260 and 30  $\mu\text{A}$ , respectively.

In this example, the reference current flowing into pin ONE is:

$$I_{\text{ref(ONE)}} = \frac{1}{16} \times 260 \times 10^{-6} = 16.25 \mu\text{A}$$

This current can be set using a current source or simply by a resistor of the appropriate value connected between pin ONE and  $V_{\text{CC(R)}}$ .

In this example, the resistor is:

$$R_{\text{ONE}} = \frac{1.5}{16.25 \times 10^{-6}} = 92.3 \text{ k}\Omega$$

In this example, the reference current at pin ZERO is:

$$I_{\text{ref(ZERO)}} = \frac{1}{4} \times 30 \times 10^{-6} = 7.5 \mu\text{A}$$

and can be set using a resistor:

$$R_{\text{ZERO}} = \frac{1.5}{7.5 \times 10^{-6}} = 200 \text{ k}\Omega$$

It should be noted that the MPD current is stabilized rather than the actual laser optical output power. Any deviations between optical output power and MPD current, known as 'tracking errors', cannot be corrected.

## Designing the modulation and bias current control loop

The optical 1 and 0 current control loop time constants are determined by on-chip capacitances. If the resulting time constants are found to be too small in a specific application, they can be increased by connecting a capacitor between pins TZERO and TONE.

The optical 1 modulation current control loop time constant ( $\tau$ ) and bandwidth (B) can be estimated using the following formulae:

$$\tau_{\text{ONE}} = (40 \times 10^{-12} + C_{\text{TONE}}) \times \frac{80 \times 10^3}{\eta_{\text{LASER}}} \quad [\text{s}] \quad (5)$$

$$B_{\text{ONE}} = \frac{1}{2\pi \times \tau_{\text{ONE}}} \quad [\text{Hz}] \quad (6)$$

$$B_{\text{ONE}} = \frac{\eta_{\text{LASER}}}{2\pi \times (40 \times 10^{-12} + C_{\text{TONE}}) \times 80 \times 10^3} \quad [\text{Hz}]$$

The optical 0 bias current control loop time constant and bandwidth can be estimated using the following formulae:

$$\tau_{\text{ZERO}} = (40 \times 10^{-12} + C_{\text{TZERO}}) \times \frac{50 \times 10^3}{\eta_{\text{LASER}}} \quad [\text{s}] \quad (7)$$

$$B_{\text{ZERO}} = \frac{1}{2\pi \times \tau_{\text{ZERO}}} \quad [\text{Hz}] \quad (8)$$

$$B_{\text{ZERO}} = \frac{\eta_{\text{LASER}}}{2\pi \times (40 \times 10^{-12} + C_{\text{TZERO}}) \times 50 \times 10^3} \quad [\text{Hz}]$$

The term  $\eta_{\text{LASER}}$  (dimensionless) in the above formulae is the product of the following two terms:

- $\eta_{\text{EO}}$  is the electro-optical efficiency which accounts for the steepness of the laser slope characteristic. It defines the rate at which the optical output power increases with modulation current, and is measured in W/A.
- R is the MPD responsivity. It determines the amount of MPD current for a given value of optical output power, and is measured in A/W.

## EXAMPLE

A laser with an MPD has the following specifications:  $P_{\text{O}} = 1 \text{ mW}$ ,  $I_{\text{th}} = 25 \text{ mA}$ ,  $\eta_{\text{EO}} = 30 \text{ mW/A}$ ,  $R = 500 \text{ mA/W}$ . The term  $I_{\text{th}}$  is the required threshold current to switch on the laser. If the laser operates just above the threshold level, it may be assumed that  $\eta_{\text{EO}}$  near the optical 0 level is 50% of  $\eta_{\text{EO}}$  near the optical 1 level, due to the slope decreasing near the threshold level.



SDH/SONET STM1/OC3 laser drivers

TZA3031AHL; TZA3031BHL;  
TZA3031U

In this example, the resulting bandwidth for the optical 1 modulation current control loop, without an external capacitor, is:

$$B_{ONE} = \frac{30 \times 10^{-3} \times 500 \times 10^{-3}}{2\pi \times 40 \times 10^{-12} \times 80 \times 10^3} \approx 750 \text{ Hz}$$

The resulting bandwidth for the optical 0 bias current control loop, without an external capacitor, is:

$$B_{ZERO} = \frac{0.5 \times 30 \times 10^{-3} \times 500 \times 10^{-3}}{2\pi \times 40 \times 10^{-12} \times 50 \times 10^3} \approx 600 \text{ Hz}$$

It is not necessary to add additional capacitance with this type of laser.

**Control loop data pattern and bit rate dependency**

The constants in equations (1) and (3) are valid when the data pattern frequently contains a sufficient number of 'constant zeroes' and 'constant ones'. A single control loop time period ( $\tau_{ONE}$  and  $\tau_{ZERO}$ ) must contain ones and zeros for at least approximately 6 ns. In practice, the optical extinction ratio increases if the bit rate increases. Therefore, it is important to use the actual data patterns and bit rate of the final application circuit for adjusting the optical levels.

The laser driver peak detectors are able to track MPD output current overshoot and undershoot conditions. Unfortunately, these conditions affect the ability of the IC to correctly interpret the high and low level MPD current. In particular, the occurrence of undershoot can have a markedly adverse effect on the interpretation of the low level MPD current.

**Additional bias by modulation 'off' current**

Although during operation, the full modulation current switches between outputs LA and LAQ, a small amount of modulation current continues to flow through the inactive pin.

For example, when the laser, whose cathode is connected to LA, is in the 'dark' part of its operating cycle (logic 0), some of the modulation 'off' current flows through LA while most of the current flows through LAQ. This value  $I_{o(mod)(off)}$  is effectively added to the bias current and is subtracted from the modulation current. Fortunately, the value correlates closely with the magnitude of the modulation current. Therefore, applications requiring low bias and low modulation are less affected. Figure 9 shows the modulation 'off' current as a function of the modulation 'on' current.

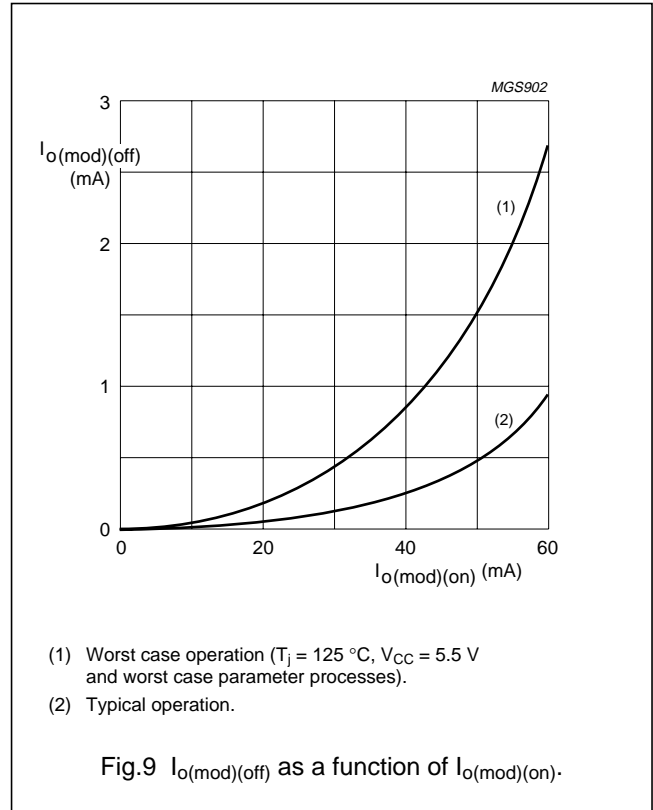

**Monitoring the bias and modulation current**

Although not recommended, the bias and modulation currents generated by the laser driver can be monitored by measuring the voltages on pins TZERO and TONE, respectively (see Fig.10). The relationship between these voltages and the corresponding currents are given as transconductance values and are specified in Chapter "Characteristics". The voltages on pins TZERO and TONE range from 1.4 to 3.4 V. Any connection to these pins should have a very high impedance value. It is mandatory to use a CMOS buffer or an amplifier with an input impedance higher than 100 GΩ and with an extremely low input leakage current (pA).

SDH/SONET STM1/OC3 laser drivers

TZA3031AHL; TZA3031BHL;  
TZA3031U

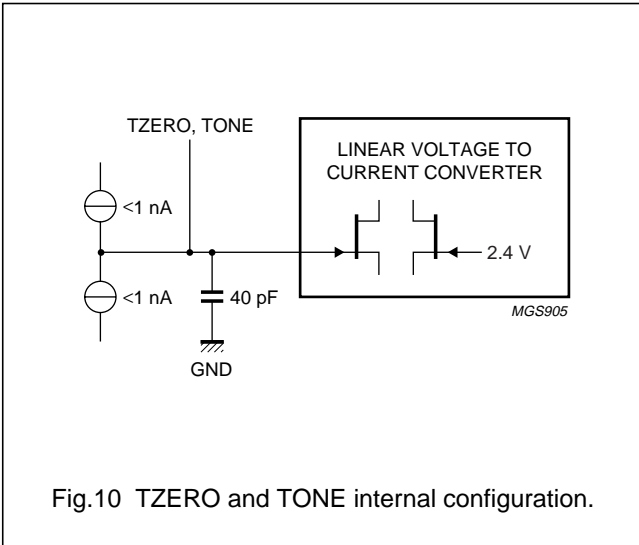

Fig.10 TZERO and TONE internal configuration.

**Manual laser override**

The automatic laser control function can be overridden by connecting voltage sources to pins TZERO and TONE to take direct control of the current sources for bias and modulation respectively. The control voltages should range from 1.4 to 3.4 V to swing the modulation current over the range 1 to 60 mA and the bias current over the range 1 to 90 mA. These current ranges are guaranteed.

Due to the tolerance range in the manufacturing process, some devices may have higher current values than those specified, as shown in Figs 12 and 13. Both figures show that temperature changes cause a slight tilting of the linear characteristic around an input voltage of 2.4 V.

Consequently, the manually controlled current level is most insensitive to temperature variations at around this value. Bias and modulation currents in excess of the specified range are not supported and should be avoided.

Currents into or out of pins TZERO and TONE in excess of 10  $\mu\text{A}$  must be avoided to prevent damage to the circuit.

**Automatic laser shut-down and laser slow start**

The laser modulation and bias currents can be rapidly switched off when a HIGH level (CMOS) is applied to pin ALS. This function allows the circuit to be shut-down in the event of an optical system malfunction. A 25 k $\Omega$  pull-down resistor defaults pin ALS to the non active state (see Fig.11).

When a LOW level is applied to pin ALS, the modulation and bias currents slowly increase to the desired values at the typical time constants of  $\tau_{\text{TONE}}$  and  $\tau_{\text{TZERO}}$ , respectively. This can be used to slow-start the laser.

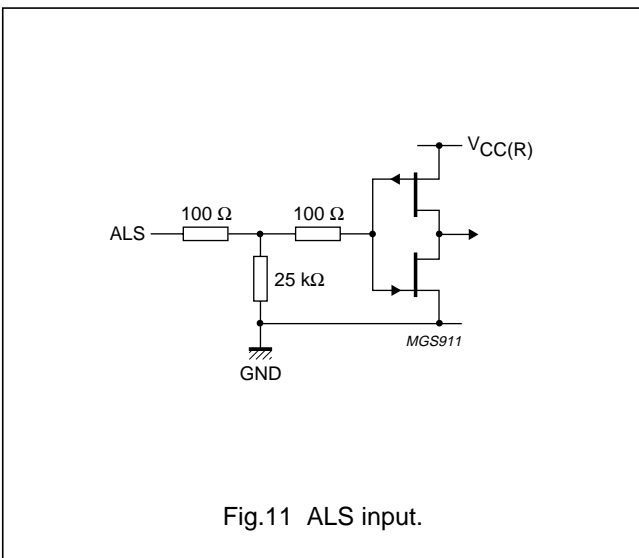
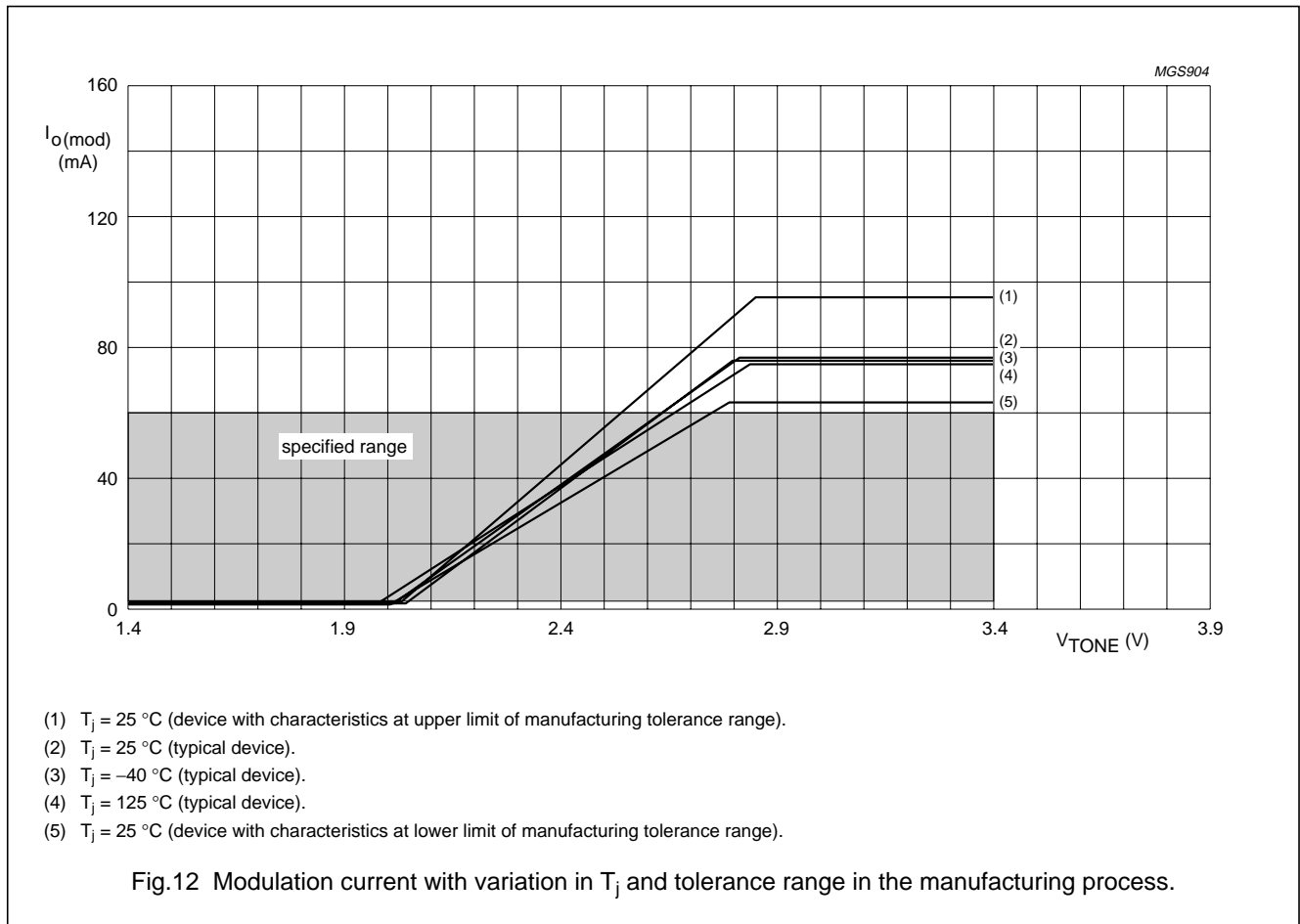

Fig.11 ALS input.

SDH/SONET STM1/OC3 laser drivers

TZA3031AHL; TZA3031BHL;  
TZA3031U



SDH/SONET STM1/OC3 laser drivers

TZA3031AHL; TZA3031BHL;  
TZA3031U

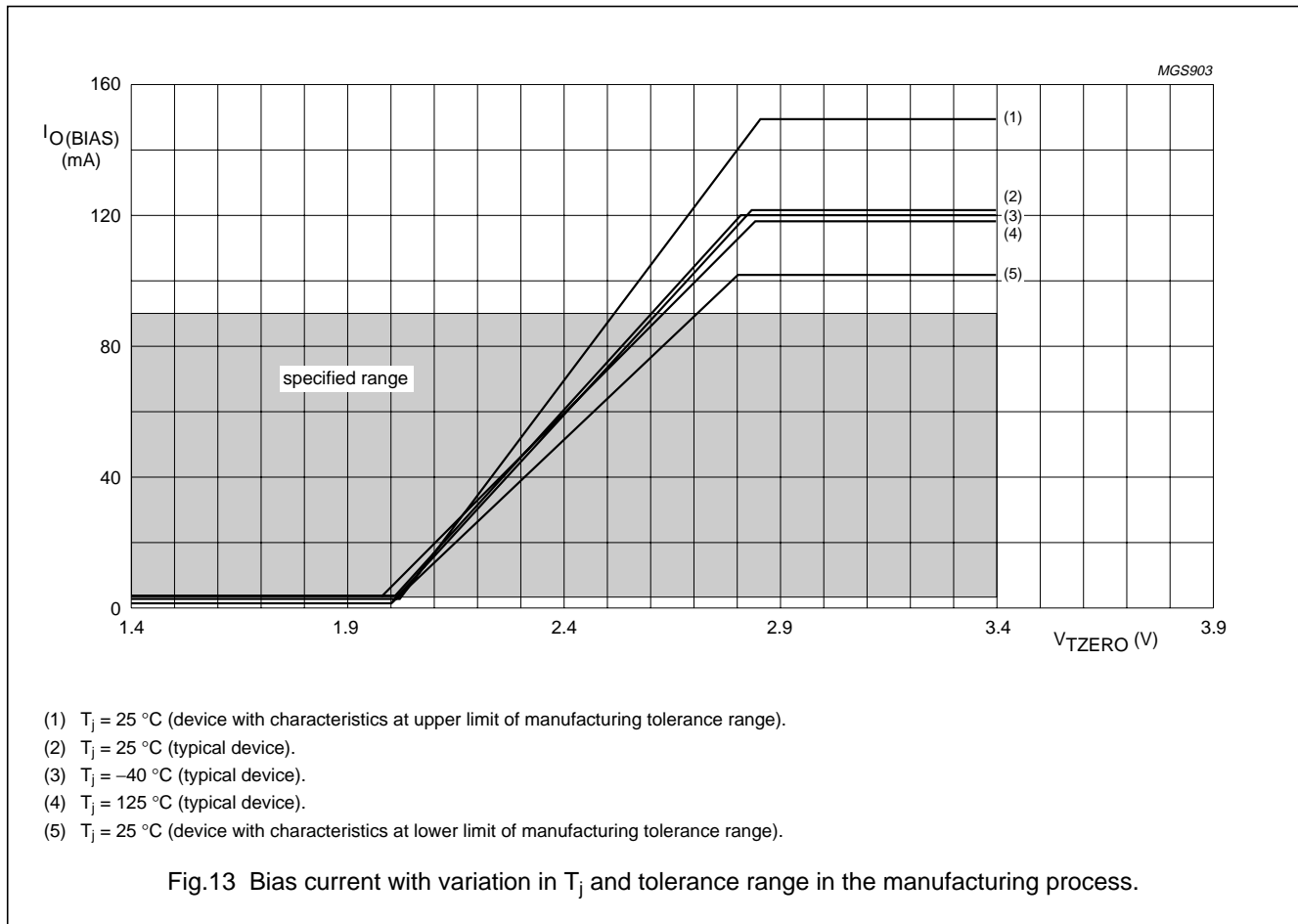

SDH/SONET STM1/OC3 laser drivers

TZA3031AHL; TZA3031BHL;  
TZA3031U

**Bias alarm for TZA3031AHL**

The bias current alarm circuit detects whenever the bias current is outside a predefined range, and generates a flag. This feature can detect excessive bias current due to laser ageing or laser malfunctioning. The current applied to pin ALARMHI should be the maximum permitted bias current value attenuated by a ratio of 1:1500. The current applied to pin ALARMLO should be the minimum permitted bias current value attenuated by a ratio of 1:300.

Like the reference currents for the laser current control loop, the alarm reference currents can be set by connecting external resistors between  $V_{CC(R)}$  and pins ALARMHI and ALARMLO (see Fig.8). The resistor values can be calculated using the following formulae:

$$R_{ALARMHI} = \frac{1.5 \times 1500}{I_{O(BIAS)(max)}} \quad [\Omega] \quad (9)$$

$$R_{ALARMLO} = \frac{1.5 \times 300}{I_{O(BIAS)(min)}} \quad [\Omega] \quad (10)$$

**Example:** The following reference currents are required to limit the bias current range from 6 to 90 mA:

$$I_{ALARMLO} = \frac{6 \times 10^{-3}}{300} = 20 \mu A$$

$$I_{ALARMHI} = \frac{90 \times 10^{-3}}{1500} = 60 \mu A$$

The corresponding resistor values are:

$$R_{ALARMHI} = \frac{1.5 \times 1500}{90 \times 10^{-3}} = 25 \text{ k}\Omega$$

$$R_{ALARMLO} = \frac{1.5 \times 300}{6 \times 10^{-3}} = 75 \text{ k}\Omega$$

If the alarm condition is true, the voltage on pin ALARM (see Fig.14) goes to a HIGH level (CMOS). This signal could be used, for example, to drive pin ALS to disable the laser driver; the signal to pin ALS has to be latched to prevent oscillation.

A hysteresis of approximately 10% is applied to both alarm functions. The attenuation ratios of 1:300 and 1:1500 are valid if the bias current rises above the reference current levels. If the bias current decreases, the ratios are 10% lower.

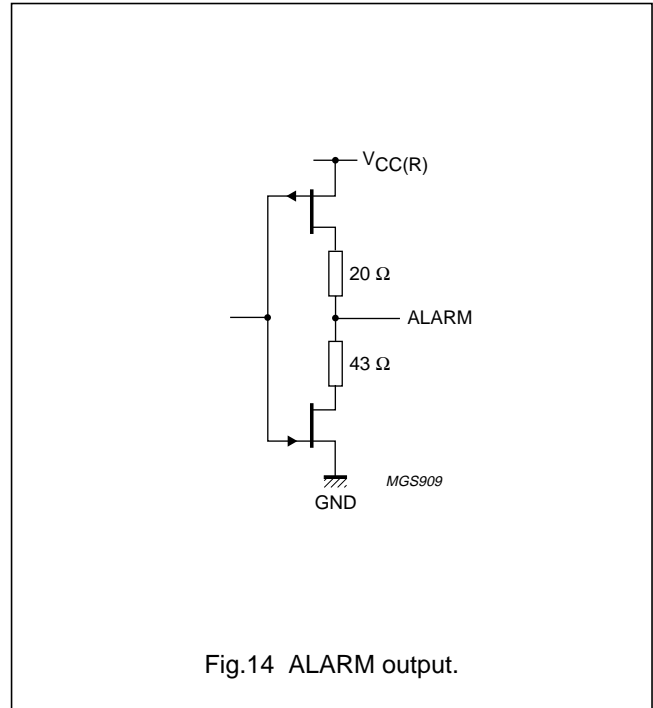

Fig.14 ALARM output.

**Accuracy of voltage on inputs: ONE, ZERO, ALARMLO, ALARMHI**

It is important to consider the accuracy of the 1.5 V level with respect to  $V_{CC(R)}$  on pins ONE and ZERO if resistors are used to set the reference currents. Although this value is independent of  $V_{CC(R)}$ , deviations from 1.5 V can be caused by:

- Input current: At  $T_j = 25 \text{ }^\circ\text{C}$ , the voltage between pin and  $V_{CC}$  varies from 1.58 V at an input current of 6  $\mu\text{A}$ , down to 1.45 V at 65  $\mu\text{A}$  and 1.41 V at 100  $\mu\text{A}$ . The range between 65  $\mu\text{A}$  and 100  $\mu\text{A}$  is only specified for ALARMLO. In the application, the input current is virtually fixed, so this variation has little effect.
- Variation in batch and individual device characteristics, not exceeding  $\pm 2\%$  from the nominal product: This variation can be compensated for where devices in the application are individually trimmed.
- Temperature: The variation in  $T_j$  is shown in Fig.15. At 30  $\mu\text{A}$  (middle of the specified range) the total variation in  $T_j$  is  $< 1\%$ , at 65  $\mu\text{A}$  it is  $< 2\%$  and at 6  $\mu\text{A}$  it is  $< 3\%$ .

SDH/SONET STM1/OC3 laser drivers

TZA3031AHL; TZA3031BHL;  
TZA3031U

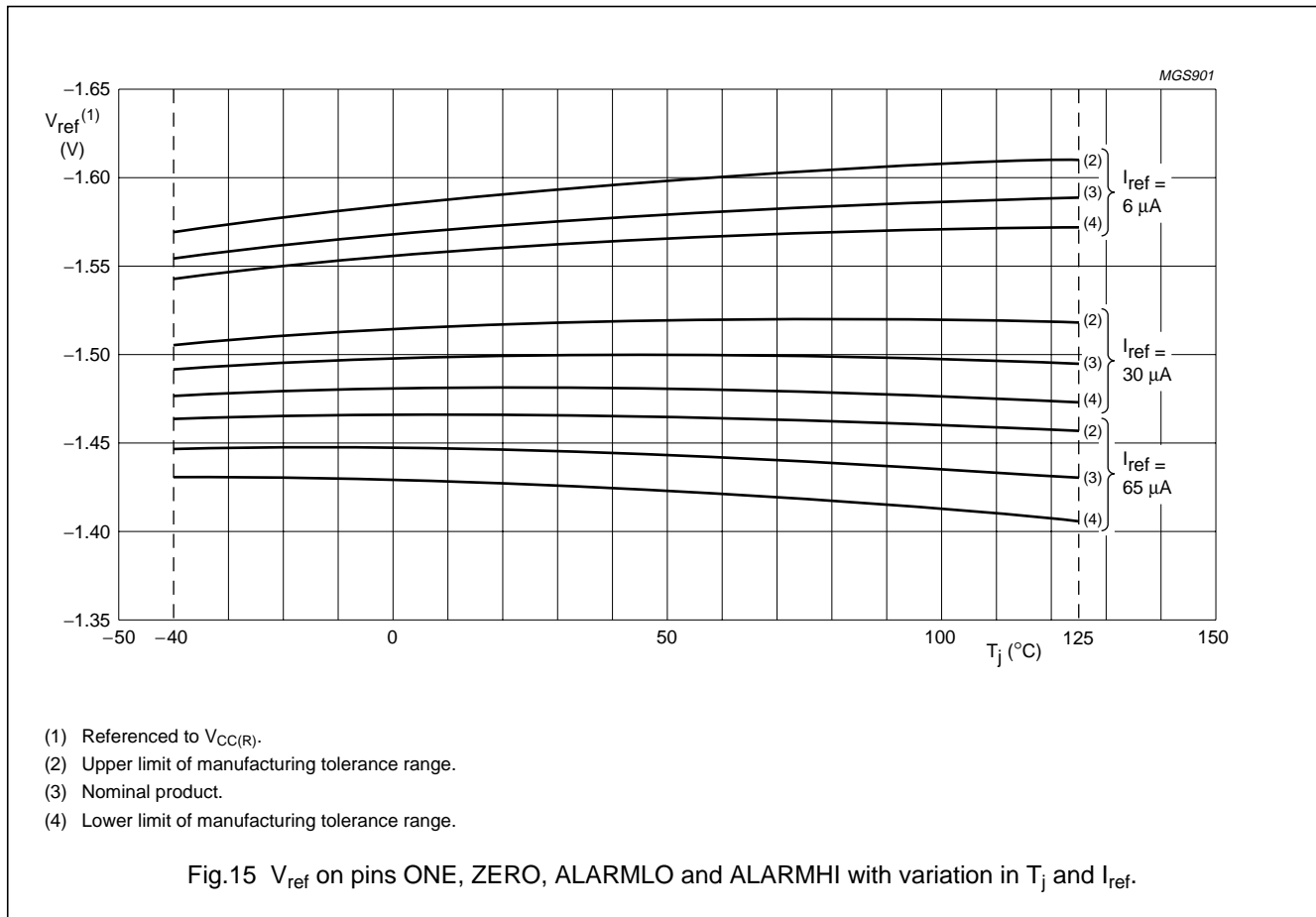

SDH/SONET STM1/OC3 laser drivers

TZA3031AHL; TZA3031BHL;  
TZA3031U

**Loop mode for TZA3031BHL**

The loop mode allows the total system application to be tested. It allows for uninhibited optical transmission through the fibre front-end (from the MPD through the transimpedance stage and the data and clock recovery unit, to the laser driver and via the laser back to the fibre). Note that the optical receiver used in conjunction with the TZA3031BHL must have a loop mode output in order to complete the test loop.

The loop mode is selected by a HIGH level on pin ENL. By default, pin ENL is pulled to a LOW level by a 25 kΩ pull-down resistor (see Fig.16).

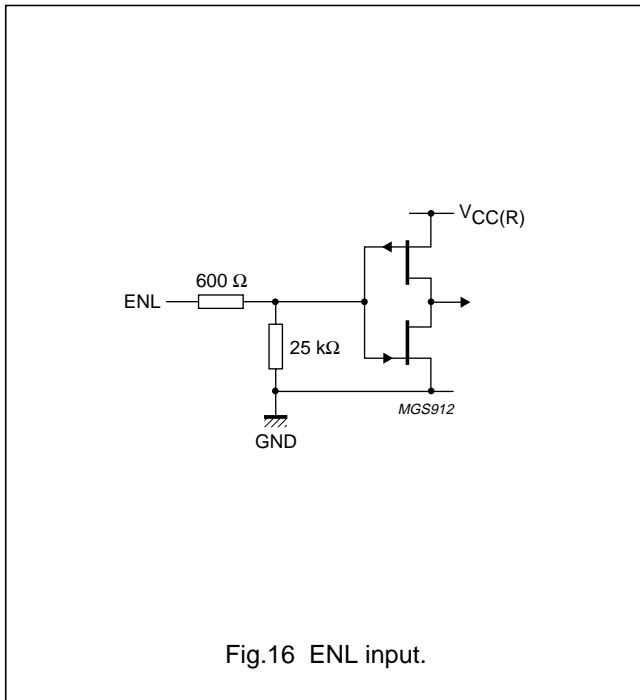

Fig.16 ENL input.

**Power supply connections**

Refer to application diagrams Figs 18 and 19. Three separate supply domains (labelled  $V_{CC(G)}$ ,  $V_{CC(B)}$ , and  $V_{CC(R)}$ ) provide isolation between the MPD current input, the high-current outputs, and the PECL or CML inputs. Each supply domain should be connected to a central  $V_{CC}$  via separate filters as shown in Figs 18 and 19. **All supply pins must be connected.** The voltage supply levels should be equal to, and in accordance with, the values specified in Chapter "Characteristics".

To maximize power supply isolation, the cathode of the MPD should be connected to  $V_{CC(G)}$  and the anode of the laser diode should be connected to  $V_{CC(B)}$ . It is recommended that the laser diode anode is also connected to a separate decoupling capacitor C9.

Generally, the inverted laser modulation output (pin LAQ) is not used. To correctly balance the output stage, an equalization network (Z1) with an impedance comparable to the laser diode is connected between pin LAQ and  $V_{CC(B)}$ .

All external components should be surface mounted devices, preferably of size 0603 or smaller.

The components must be mounted as close to the IC as possible.

It is especially recommended to mount the following components very close to the IC:

- Power supply decoupling capacitors C2, C3 and C4
- Input matching network on pins DIN, DINQ, DLOOP and DLOOPQ
- Capacitor C5 on pin MONIN
- Output matching network Z1 at the unused output
- The laser.

**Bare die ground**

In addition to the separate  $V_{CC}$  domains, the bare die contains three corresponding ground (GND) domains. Isolation between the GND domains is limited due to the finite substrate conductance.

Mount the die preferably on a large and highly conductive grounded die pad. **All GND pads must be bonded to the die pad.** The external ground is thus ideally combined with the die ground to avoid ground bounce problems.

**Layout recommendations**

Layout recommendations for the TZA3031AHL and TZA3031BHL can be found in application note "AN98090 Fiber optic transceiverboard STM1/4/8, OC3,12,24, FC/GE".

## SDH/SONET STM1/OC3 laser drivers

TZA3031AHL; TZA3031BHL;  
TZA3031U**LIMITING VALUES**

In accordance with the Absolute Maximum Rating System (IEC 60134).

SYMBOL	PARAMETER	MIN.	MAX.	UNIT
$V_{CC}$	supply voltage	-0.5	+6	V
$V_n$	DC voltage on			
	pin MONIN	1.3	$V_{CC} + 0.5$	V
	pins TONE and TZERO	-0.5	$V_{CC} + 0.5$	V
	pin BGAP	-0.5	+3.2	V
	pin BIAS	-0.5	$V_{CC} + 0.5$	V
	pins LA and LAQ	1.3	$V_{CC} + 0.5$	V
	pin ALS	-0.5	$V_{CC} + 0.5$	V
	pins ONE and ZERO	-0.5	$V_{CC} + 0.5$	V
	pins DIN and DINQ	-0.5	$V_{CC} + 0.5$	V
	pin ALARM (TZA3031AHL)	-0.5	$V_{CC} + 0.5$	V
	pins ALARMHI and ALARMLO (TZA3031AHL)	-0.5	$V_{CC} + 0.5$	V
	pins DLOOP and DLOOPQ (TZA3031BHL)	-0.5	$V_{CC} + 0.5$	V
	pin ENL (TZA3031BHL)	-0.5	$V_{CC} + 0.5$	V
$I_n$	DC current on			
	pin MONIN	-0.5	+2.5	mA
	pins TONE and TZERO	-0.5	+0.5	mA
	pin BGAP	-2.0	+2.5	mA
	pin BIAS	-0.5	+200	mA
	pins LA and LAQ	-0.5	+100	mA
	pin ALS	-0.5	+0.5	mA
	pins ONE and ZERO	-0.5	+0.5	mA
	pins DIN and DINQ	-0.5	+0.5	mA
	pin ALARM (TZA3031AHL)	-0.5	+10	mA
	pins ALARMHI and ALARMLO (TZA3031AHL)	-0.5	+0.5	mA
	pins DLOOP and DLOOPQ (TZA3031BHL)	-0.5	+0.5	mA
	pin ENL (TZA3031BHL)	-0.5	+0.5	mA
$T_{amb}$	ambient temperature	-40	+85	°C
$T_j$	junction temperature	-40	+125	°C
$T_{stg}$	storage temperature	-65	+150	°C

**THERMAL CHARACTERISTICS**

SYMBOL	PARAMETER	VALUE	UNIT
$R_{th(j-s)}$	thermal resistance from junction to solder point	15	K/W
$R_{th(j-c)}$	thermal resistance from junction to case	23	K/W



## SDH/SONET STM1/OC3 laser drivers

TZA3031AHL; TZA3031BHL;  
TZA3031U**CHARACTERISTICS** $V_{CC} = 4.5$  to  $5.5$  V;  $T_{amb} = -40$  to  $+85$  °C; all voltages measured with respect to GND.

SYMBOL	PARAMETER	CONDITIONS	MIN.	TYP.	MAX.	UNIT
<b>Supplies</b>						
$V_{CC}$	supply voltage		4.5	5.0	5.5	V
$I_{CC(R)}$	supply current (R)		–	4	10	mA
$I_{CC(G)}$	supply current (G)		12	18	26	mA
$I_{CC(B)}$	supply current (B)	ALS LOW; note 1	20	41	65	mA
		ALS HIGH	–	3	5	mA
$I_{CC(tot)}$	total supply current	ALS LOW; note 1	32	63	101	mA
		ALS HIGH	12	25	41	mA
$P_{tot}$	total power dissipation	ALS LOW; note 2	145	430	925	mW
		ALS HIGH; note 2	50	125	225	mW
<b>Data inputs: pins DIN and DINQ (and pins DLOOP and DLOOPQ on TZA3031BHL); see Fig.17</b>						
$V_{i(p-p)}$	input voltage (peak-to-peak value)	single-ended	100	250	800	mV
$V_{IO}$	input offset voltage		–25	–	+25	mV
$V_{I(min)}$	minimum input voltage		$V_{CC(R)} - 2$	–	–	V
$V_{I(max)}$	maximum input voltage		–	–	$V_{CC(R)} + 0.25$	V
$Z_i$	input impedance	for low frequencies; single-ended	7	10	13	k $\Omega$
<b>CMOS inputs: pin ALS (and pin ENL on TZA3031BHL)</b>						
$V_{IL}$	LOW-level input voltage		–	–	2	V
$V_{IH}$	HIGH-level input voltage		3	–	–	V
$R_{pd(ALS)}$	internal pull-down resistance on pin ALS		21	25.5	30	k $\Omega$
$R_{pd(ENL)}$	internal pull-down resistance on pin ENL		15	25	35	k $\Omega$
<b>CMOS output: pin ALARM (on TZA3031AHL)</b>						
$V_{OL}$	LOW-level output voltage	$I_{OH} = -200$ $\mu$ A	0	–	0.2	V
$V_{OH}$	HIGH-level output voltage	$I_{OH} = 200$ $\mu$ A	$V_{CC} - 0.2$	–	$V_{CC}$	V
<b>Monitor photodiode input: pin MONIN</b>						
$V_I$	DC input voltage		1.2	1.8	2.4	V
$I_{MPD}$	monitor photodiode current	laser optical 0	24	–	260	$\mu$ A
		laser optical 1	96	–	1040	$\mu$ A
$C_{MPD}$	monitor photodiode capacitance	note 3	30	–	50	pF

## SDH/SONET STM1/OC3 laser drivers

TZA3031AHL; TZA3031BHL;  
TZA3031U

SYMBOL	PARAMETER	CONDITIONS	MIN.	TYP.	MAX.	UNIT
<b>Control loop reference current inputs: pins ONE and ZERO</b>						
$I_{\text{ref(ONE)}}$	reference current on pin ONE	note 4	6	–	65	$\mu\text{A}$
$V_{\text{ref(ONE)}}$	reference voltage on pin ONE	referenced to $V_{\text{CC(R)}}$ ; note 5	–	–1.5	–	V
$\alpha_{\text{(ONE)}}$	attenuation ratio of $I_{\text{ref(ONE)}}$ to $I_{\text{MPD(ONE)}}$	note 6	–	16	–	–
$I_{\text{ref(ZERO)}}$	reference current on pin ZERO	note 4	6	–	65	$\mu\text{A}$
$V_{\text{ref(ZERO)}}$	reference voltage on pin ZERO	referenced to $V_{\text{CC(R)}}$ ; note 5	–	–1.5	–	V
$\alpha_{\text{(ZERO)}}$	attenuation ratio of $I_{\text{ref(ZERO)}}$ to $I_{\text{MPD(ZERO)}}$	note 6	–	4	–	–
<b>Control loop time constants: pins TONE and TZERO</b>						
$V_{\text{TONE}}$	voltage on pin TONE	floating output	1.4	–	3.4	V
$g_{\text{m(TONE)}}$	transconductance of pin TONE	note 7	60	95	130	$\text{mA/V}$
$V_{\text{TZERO}}$	voltage on pin TZERO	floating output	1.4	–	3.4	V
$g_{\text{m(TZERO)}}$	transconductance of pin TZERO	note 8	100	145	190	$\text{mA/V}$
<b>Laser modulation current outputs: pins LA and LAQ</b>						
$I_{\text{o(mod)(on)}}$	modulation output current (active pin)	note 9	2.5	–	60	$\text{mA}$
$I_{\text{o(mod)(off)}}$	modulation output current (inactive pin)	$I_{\text{o(mod)(on)} = 30\text{mA}}$	–	–	0.5	$\text{mA}$
		$I_{\text{o(mod)(on)} = 60\text{mA}}$	–	–	2.8	$\text{mA}$
$I_{\text{o(mod)(ALS)}}$	output current during laser shutdown		–	–	10	$\mu\text{A}$
$V_{\text{O}}$	output voltage		2	–	5	V
$t_{\text{r}}$	current rise time	note 10	–	120	300	ps
$t_{\text{f}}$	current fall time	note 10	–	120	300	ps
$J_{\text{o(p-p)}}$	intrinsic electrical output jitter (peak-to-peak value)	note 11	–	–	50	$\text{mUI}$
<b>Laser bias current output: pin BIAS</b>						
$I_{\text{O(BIAS)}}$	bias output current	note 12	2.8	–	90	$\text{mA}$
$I_{\text{O(BIAS)(ALS)}}$	output current during laser shutdown		–	–	10	$\mu\text{A}$
$t_{\text{res(off)}}$	response time after laser shutdown	$I_{\text{O(BIAS)} = 90\text{ mA}}$ ; note 13	–	–	1	$\mu\text{s}$
$V_{\text{O(BIAS)}}$	bias output voltage		1	–	5	V

## SDH/SONET STM1/OC3 laser drivers

TZA3031AHL; TZA3031BHL;  
TZA3031U

SYMBOL	PARAMETER	CONDITIONS	MIN.	TYP.	MAX.	UNIT
<b>Alarm reference current inputs: pins ALARMHI and ALARMLO (TZA3031AHL)</b>						
$I_{\text{ref}}(\text{ALARMLO})$	reference current on pin ALARMLO	note 14	6	–	100	$\mu\text{A}$
$V_{\text{ref}}(\text{ALARMLO})$	reference voltage on pin ALARMLO	referenced to $V_{\text{CC(R)}}$	–	–1.5	–	V
$\alpha(\text{ALARMLO})$	attenuation ratio of $I_{\text{ref}}(\text{ALARMLO})$ to $I_{\text{O(BIAS)(min)}}$	note 15	200	315	400	
$I_{\text{O(BIAS)(min)(hys)}}$	minimum bias current detection hysteresis		7.5	10	15	%
$I_{\text{ref}}(\text{ALARMHI})$	reference current on pin ALARMHI	note 14	6	–	65	$\mu\text{A}$
$V_{\text{ref}}(\text{ALARMHI})$	reference voltage on pin ALARMHI	referenced to $V_{\text{CC(R)}}$	–	–1.5	–	V
$\alpha(\text{ALARMHI})$	attenuation ratio of $I_{\text{ref}}(\text{ALARMHI})$ to $I_{\text{O(BIAS)(max)}}$	note 15	1300	1500	1700	
$I_{\text{O(BIAS)(max)(hys)}}$	maximum bias current detection hysteresis		7.5	10	15	%
<b>Reference voltage output: pin BGAP</b>						
$V_{\text{O}}$	output voltage		1.165	1.20	1.235	$\mu\text{A}$

**Notes**

## 1. Supply current:

- The values do not include the modulation and bias currents through pins LA, LAQ and BIAS.
- Minimum value refers to  $V_{\text{TONE}} = 1.4 \text{ V}$  at  $I_{\text{O(mod)(min)}}$  and  $V_{\text{TZERO}} = 1.4 \text{ V}$  at  $I_{\text{O(BIAS)(min)}}$ .
- Maximum value refers to  $V_{\text{TONE}} = 3.4 \text{ V}$  at  $I_{\text{O(mod)(max)}}$  and  $V_{\text{TZERO}} = 3.4 \text{ V}$  at  $I_{\text{O(BIAS)(max)}}$ .
- A first order estimate of the typical value of  $I_{\text{CC(tot)}}$  as a function of  $T_{\text{j}}$ ,  $I_{\text{O(mod)}}$ , and  $I_{\text{O(BIAS)}}$  is:

$$I_{\text{CC(tot)}} = 55.6 \text{ mA} + 0.0015 \times I_{\text{O(BIAS)}}[\text{mA}] \times I_{\text{O(mod)(on)}}[\text{mA}] \times \left(1 - \left[0.026 \times \frac{T_{\text{j}}[\text{°C}]}{25}\right]\right).$$

## 2. Power dissipation:

- The value for  $P_{\text{tot}}$  includes the modulation and bias currents through pins LA, LAQ and BIAS.
- The minimum value for  $P_{\text{tot}}$  is the on-chip dissipation when  $V_{\text{TONE}} = 1.4 \text{ V}$  at  $I_{\text{O(mod)(min)}}$ ,  $V_{\text{LA}} = V_{\text{LAQ}} = 2 \text{ V}$ ,  $V_{\text{TZERO}} = 1.4 \text{ V}$  at  $I_{\text{O(BIAS)(min)}}$ ,  $V_{\text{O(BIAS)}} = 1 \text{ V}$ , and parameter processes are at a minimum.
- The maximum value for  $P_{\text{tot}}$  is the on-chip dissipation when  $V_{\text{TONE}} = 3.4 \text{ V}$  at  $I_{\text{O(mod)(max)}}$ ,  $V_{\text{LA}} = V_{\text{LAQ}} = 2 \text{ V}$ ,  $V_{\text{TZERO}} = 3.4 \text{ V}$  at  $I_{\text{O(BIAS)(max)}}$ ,  $V_{\text{O(BIAS)}} = 1 \text{ V}$ , and parameter processes are at a maximum.
- $P_{\text{tot}} = I_{\text{CC(tot)}} \times V_{\text{CC}} + I_{\text{O(BIAS)}} \times V_{\text{O(BIAS)}} + I_{\text{LA}} \times V_{\text{LA}}$  with  $I_{\text{O(mod)(on)}}$  flowing through pin LA.

## 3. The minimum value of the capacitance on pin MONIN is required to prevent instability.

4. The reference currents can be set by connecting external resistors between  $V_{\text{CC}}$  and pins ONE and ZERO (see Section "Automatic laser control"). The corresponding MPD current range for optical 1 is from 96 to 1040  $\mu\text{A}$ . The MPD current range for optical 0 is from 24 to 260  $\mu\text{A}$ .

## 5. See Section "Accuracy of voltage on inputs: ONE, ZERO, ALARMLO, ALARMHI".

## 6. See Section "Automatic laser control".

## 7. The specified transconductance is the ratio between the modulation current on pins LA or LAQ and the voltage on pin TONE, under small signal conditions.

## SDH/SONET STM1/OC3 laser drivers

TZA3031AHL; TZA3031BHL;  
TZA3031U

8. The specified transconductance is the ratio between the bias current on pin BIAS and the voltage on pin TZERO, under small signal conditions.
9. These are the guaranteed values; the lowest attainable output current will always be lower than 2.5 mA, and the highest output current will always be higher than 60 mA.
10. The voltage rise and fall times (20% to 80%) can have larger values due to capacitive effects. Specifications are guaranteed by design and characterization. Each device is tested at full operating speed to guarantee RF functionality.
11. Measured in a frequency band from 250 kHz to 5 MHz, according to "ITU-T Recommendation G.813". The electrically generated (current) jitter is assumed to be less than 50% of the optical output jitter. The specification is guaranteed by design.
12. These are the guaranteed values; the lowest output current will always be less than 2.8 mA and the highest output current will always be more than 90 mA.
13. The response time is defined as the delay between the onset of the ramp on pin ALS (at 10% of the HIGH level) and the extinction of the bias current (at 10% of the original value).
14. The reference currents can be set by connecting a resistor between pin ALARMLO and  $V_{CC(R)}$  and between pin ALARMHI and  $V_{CC(R)}$ ; for detailed information, see Section "Bias alarm for TZA3031AHL". The corresponding low-bias threshold range is 1.8 to 19.5 mA. The high-bias threshold range is 9 to 97.5 mA.
15. See Section "Bias alarm for TZA3031AHL".

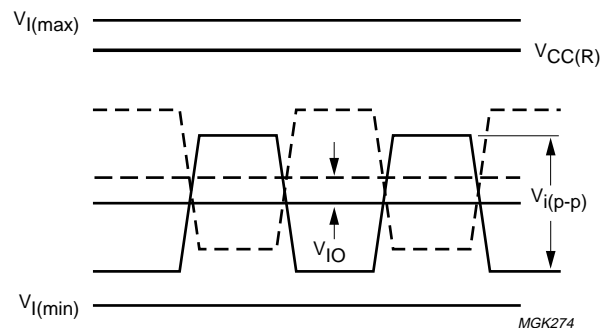
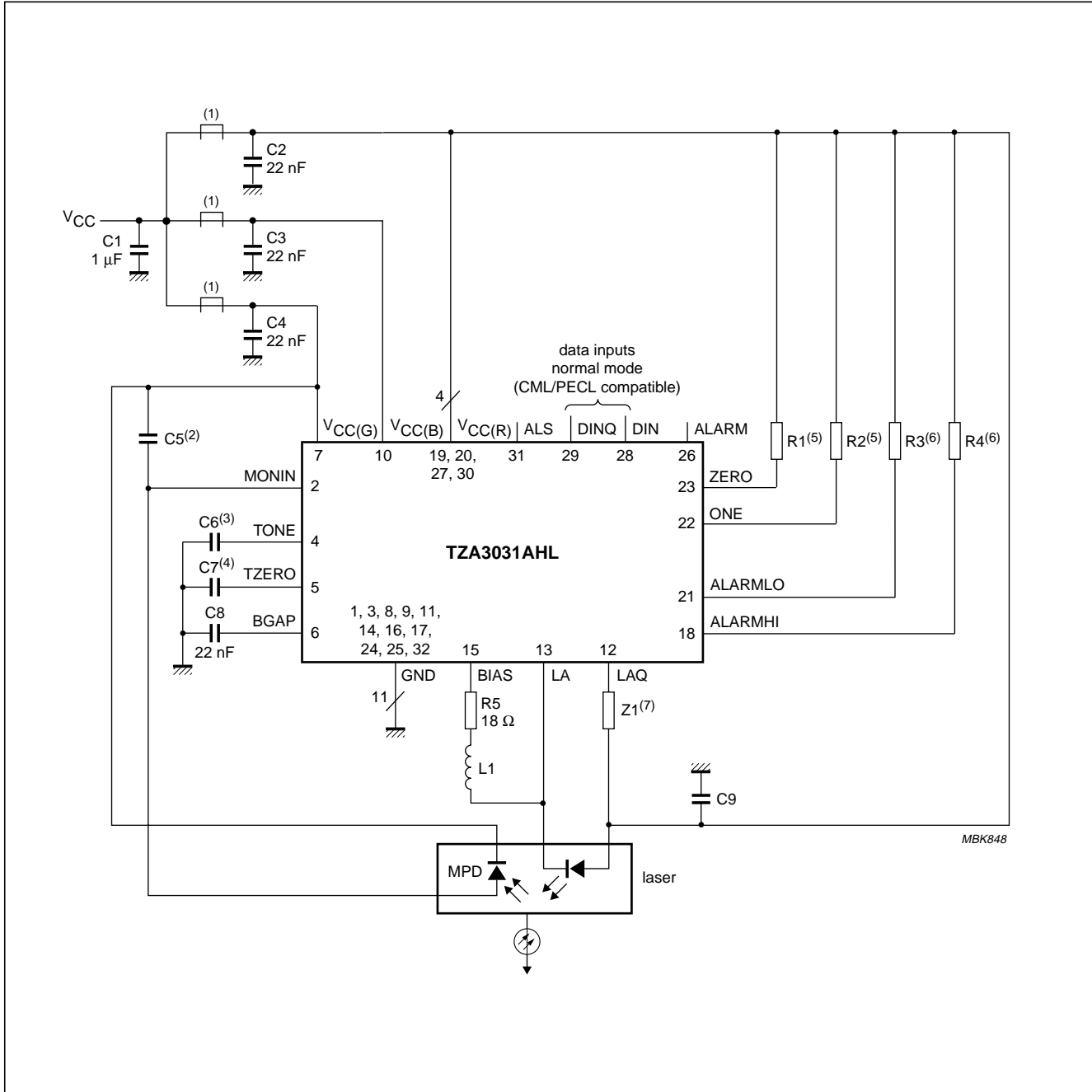

Fig.17 Logic level symbol definitions for data inputs.

SDH/SONET STM1/OC3 laser drivers

TZA3031AHL; TZA3031BHL;  
TZA3031U

APPLICATION INFORMATION



- (1) Ferrite bead e.g. Murata BLM31A601S.
- (2) C5 is required to meet the minimum capacitance value on pin MONIN (optional, see Section "Automatic laser control").
- (3) C6 enhances modulation control loop time constant (optional).
- (4) C7 enhances bias control loop time constant (optional).
- (5) R1 and R2 are used for setting optical 0 and optical 1 reference currents (see Section "Automatic laser control").
- (6) R3 and R4 are used for setting minimum and maximum bias currents (see Section "Bias alarm for TZA3031AHL").
- (7) Z1 is required for balancing the output stage (see Section "Power supply connections").

Fig.18 Application diagram showing the TZA3031AHL configured for 155 Mbits/s (STM1/OC3).

SDH/SONET STM1/OC3 laser drivers

TZA3031AHL; TZA3031BHL;  
TZA3031U

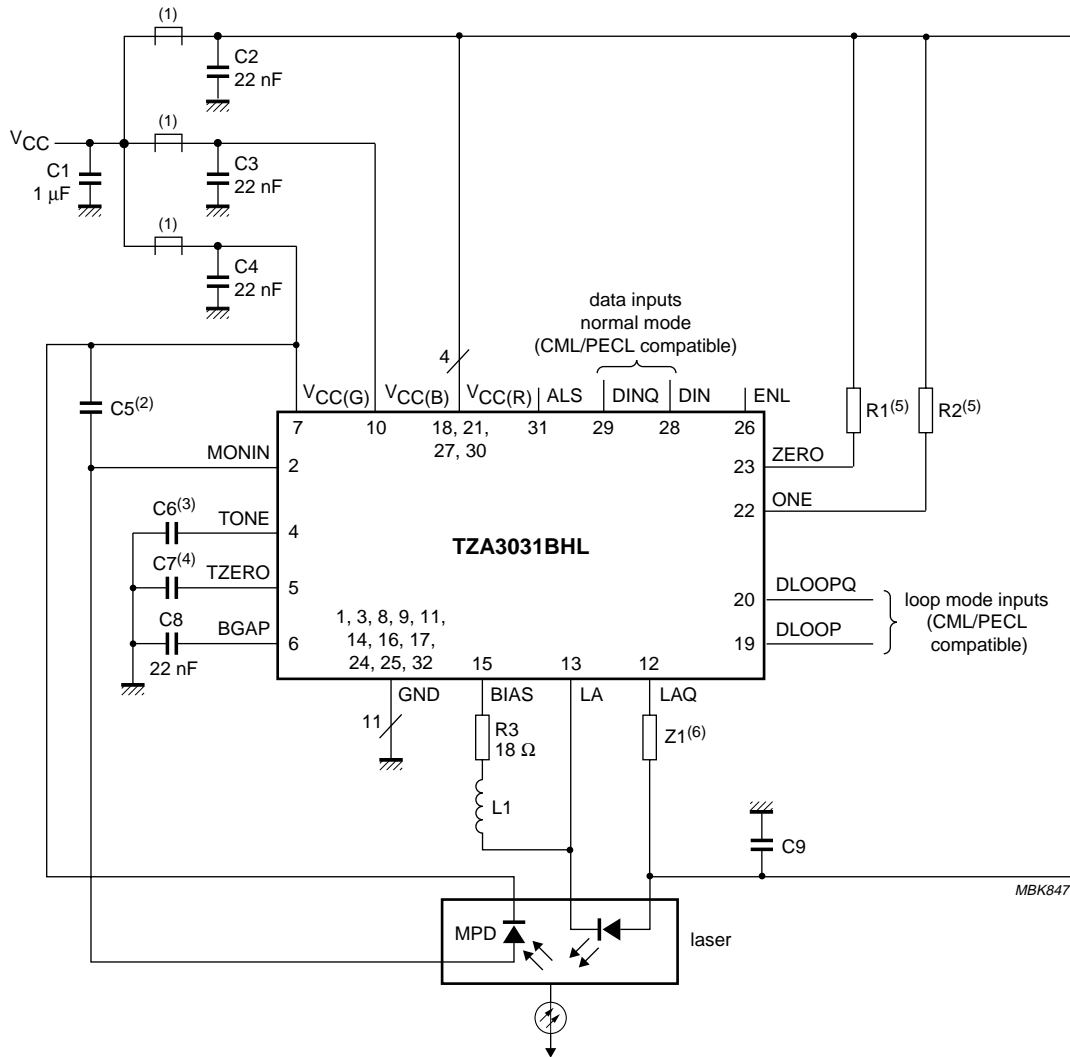

- (1) Ferrite bead e.g. Murata BLM31A601S.
- (2) C5 is required to meet the minimum capacitance value on pin MONIN (optional, see Section "Automatic laser control").
- (3) C6 enhances modulation control loop time constant (optional).
- (4) C7 enhances bias control loop time constant (optional).
- (5) R1 and R2 are used for setting optical 0 and optical 1 reference currents (see Section "Automatic laser control").
- (6) Z1 is required for balancing the output stage (see Section "Power supply connections").

Fig.19 Application diagram showing the TZA3031BHL configured for 155 Mbits/s (STM1/OC3).

## SDH/SONET STM1/OC3 laser drivers

TZA3031AHL; TZA3031BHL;  
TZA3031U

## BONDING PAD LOCATIONS

SYMBOL	PAD	COORDINATES <sup>(1)</sup>	
		x	y
GND	1	-664	-910
MONIN	2	-524	-910
GND	3	-367	-910
IGM	4	-227	-910
TONE	5	-70	-910
TZERO	6	+87	-910
BGAP	7	+244	-910
V <sub>CC(G)</sub>	8	+384	-910
V <sub>CC(G)</sub>	9	+524	-910
GND	10	+664	-910
GND	11	+910	-630
V <sub>CC(B)</sub>	12	+910	-490
V <sub>CC(B)</sub>	13	+910	-350
GND	14	+910	-210
LAQ	15	+910	-70
LA	16	+910	+70
GND	17	+910	+210
BIAS	18	+910	+350
GND	19	+910	+490
GND	20	+910	+630
GND	21	+681	+910
ALARMHI	22	+541	+910

SYMBOL	PAD	COORDINATES <sup>(1)</sup>	
		x	y
V <sub>CC(R)</sub>	23	+384	+910
DLOOP	24	+227	+910
DLOOPQ	25	+87	+910
V <sub>CC(R)</sub>	26	-70	+910
ALARMLO	27	-210	+910
ONE	28	-367	+910
ZERO	29	-524	+910
GND	30	-681	+910
GND	31	-910	+681
ALARM	32	-910	+541
ENL	33	-910	+384
V <sub>CC(R)</sub>	34	-910	+227
DIN	35	-910	+70
DINQ	36	-910	-70
V <sub>CC(R)</sub>	37	-910	-227
ALS	38	-910	-367
GND	39	-910	-551
GND	40	-910	-664

**Note**

1. All x and y coordinates represent the position of the centre of the pad in  $\mu\text{m}$  with respect to the centre of the die (see Fig.20).

SDH/SONET STM1/OC3 laser drivers

TZA3031AHL; TZA3031BHL;  
TZA3031U

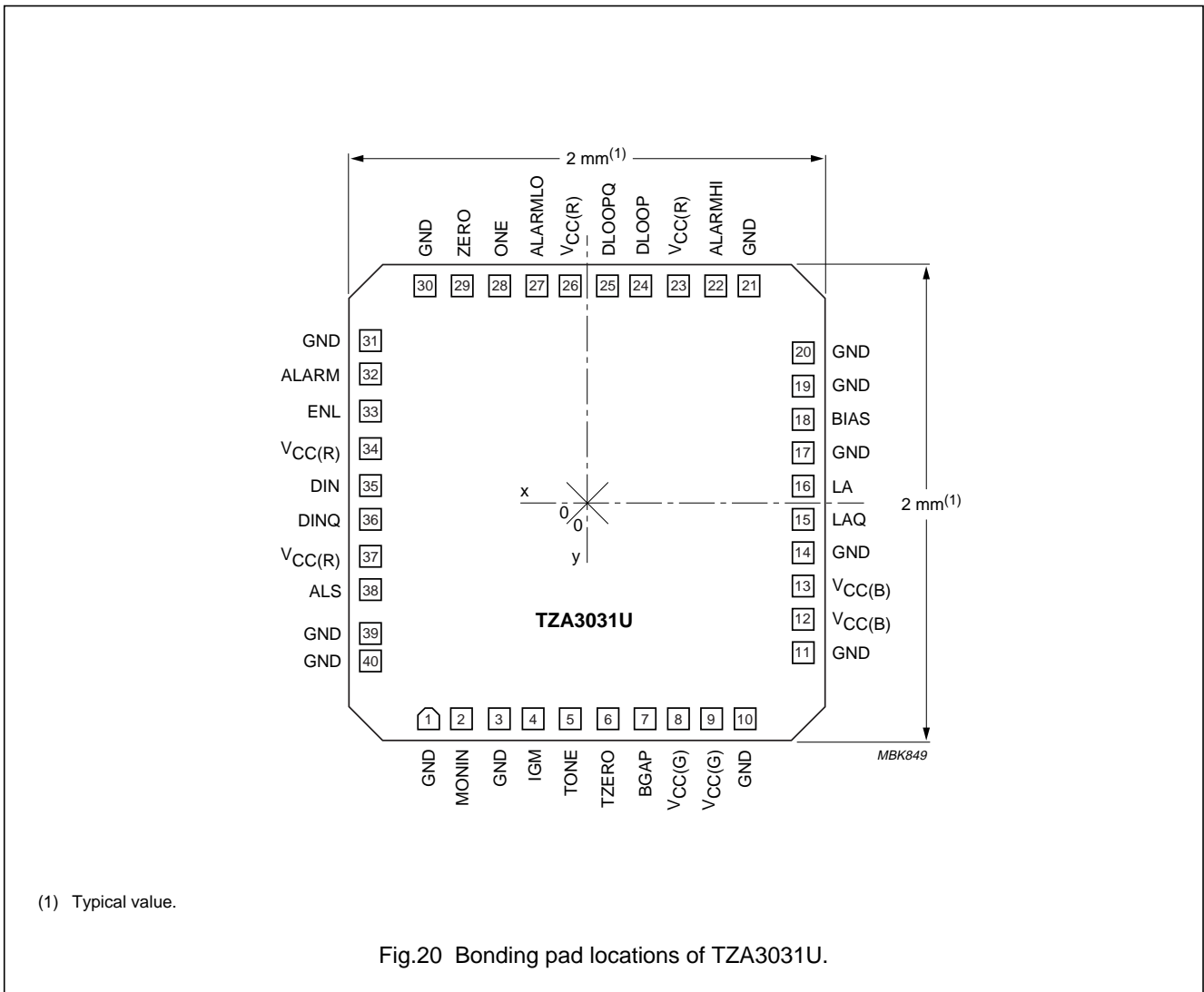

**Table 1** Physical characteristics of bare die

PARAMETER	VALUE
Glass passivation	2.1 μm PSG (PhosphoSilicate Glass) on top of 0.7 μm silicon nitride
Bonding pad dimension	minimum dimension of exposed metallization is 90 × 90 μm (pad size = 100 × 100 μm)
Metallization	1.2 μm AlCu (1% Cu)
Thickness	380 μm nominal
Size	2.000 × 2.000 mm (4.000 mm <sup>2</sup> )
Backing	silicon; electrically connected to GND potential through substrate contacts
Attach temperature	<430 °C; glue is recommended for attaching die
Attach time	<15 s



SDH/SONET STM1/OC3 laser drivers

TZA3031AHL; TZA3031BHL;  
TZA3031U

PACKAGE OUTLINE

LQFP32: plastic low profile quad flat package; 32 leads; body 5 x 5 x 1.4 mm

SOT401-1

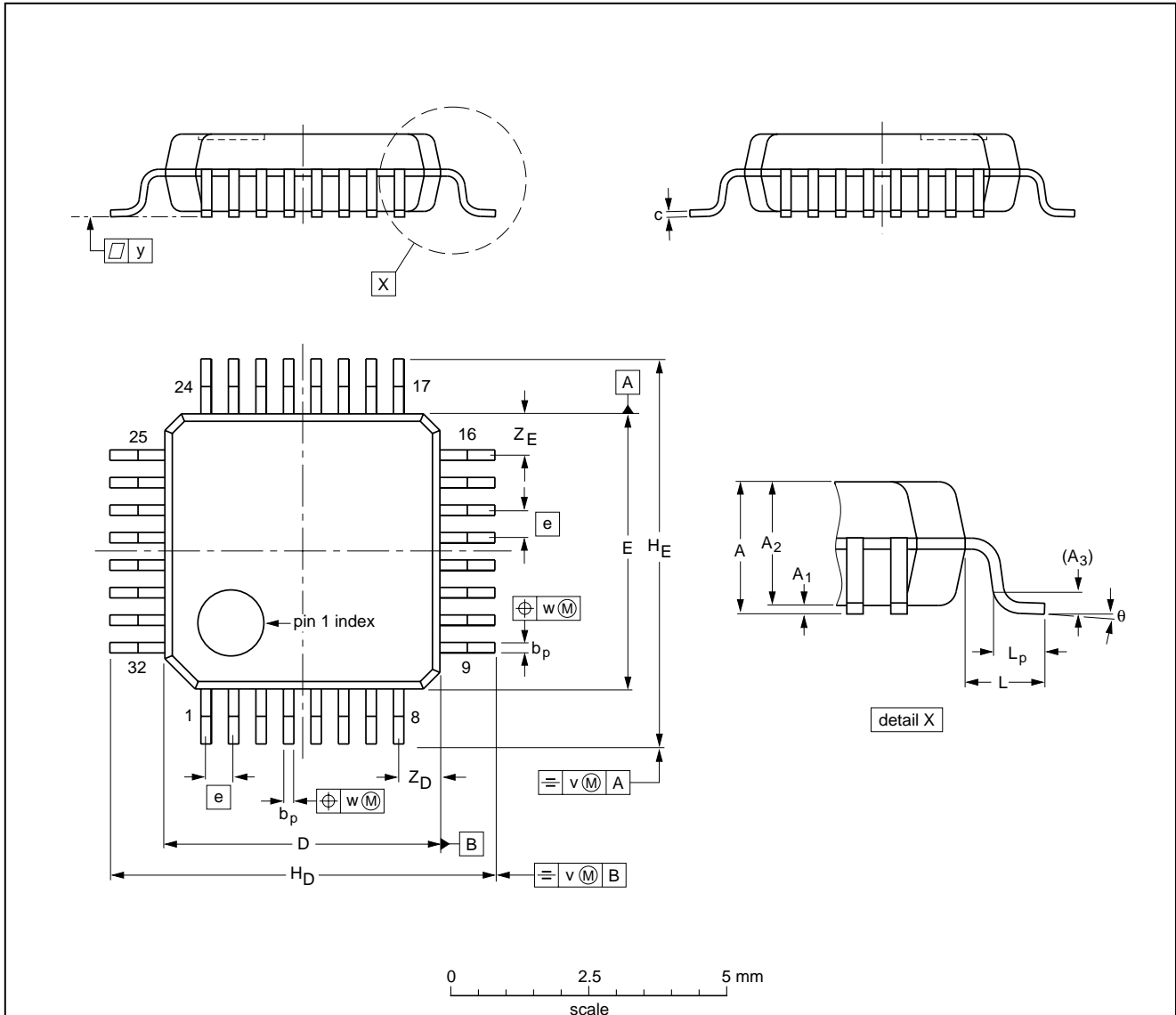

DIMENSIONS (mm are the original dimensions)

UNIT	A max.	A <sub>1</sub>	A <sub>2</sub>	A <sub>3</sub>	b <sub>p</sub>	c	D <sup>(1)</sup>	E <sup>(1)</sup>	e	H <sub>D</sub>	H <sub>E</sub>	L	L <sub>p</sub>	v	w	y	Z <sub>D</sub> <sup>(1)</sup>	Z <sub>E</sub> <sup>(1)</sup>	θ
mm	1.60	0.15 0.05	1.5 1.3	0.25	0.27 0.17	0.18 0.12	5.1 4.9	5.1 4.9	0.5	7.15 6.85	7.15 6.85	1.0	0.75 0.45	0.2	0.12	0.1	0.95 0.55	0.95 0.55	7° 0°

Note

1. Plastic or metal protrusions of 0.25 mm maximum per side are not included.

OUTLINE VERSION	REFERENCES			EUROPEAN PROJECTION	ISSUE DATE
	IEC	JEDEC	EIAJ		
SOT401-1	136E01	MS-026			99-12-27 00-01-19

## SDH/SONET STM1/OC3 laser drivers

TZA3031AHL; TZA3031BHL;  
TZA3031U**SOLDERING****Introduction to soldering surface mount packages**

This text gives a very brief insight to a complex technology. A more in-depth account of soldering ICs can be found in our *"Data Handbook IC26; Integrated Circuit Packages"* (document order number 9398 652 90011).

There is no soldering method that is ideal for all surface mount IC packages. Wave soldering is not always suitable for surface mount ICs, or for printed-circuit boards with high population densities. In these situations reflow soldering is often used.

**Reflow soldering**

Reflow soldering requires solder paste (a suspension of fine solder particles, flux and binding agent) to be applied to the printed-circuit board by screen printing, stencilling or pressure-syringe dispensing before package placement.

Several methods exist for reflowing; for example, infrared/convection heating in a conveyor type oven. Throughput times (preheating, soldering and cooling) vary between 100 and 200 seconds depending on heating method.

Typical reflow peak temperatures range from 215 to 250 °C. The top-surface temperature of the packages should preferably be kept below 230 °C.

**Wave soldering**

Conventional single wave soldering is not recommended for surface mount devices (SMDs) or printed-circuit boards with a high component density, as solder bridging and non-wetting can present major problems.

To overcome these problems the double-wave soldering method was specifically developed.

If wave soldering is used the following conditions must be observed for optimal results:

- Use a double-wave soldering method comprising a turbulent wave with high upward pressure followed by a smooth laminar wave.
- For packages with leads on two sides and a pitch (e):
  - larger than or equal to 1.27 mm, the footprint longitudinal axis is **preferred** to be parallel to the transport direction of the printed-circuit board;
  - smaller than 1.27 mm, the footprint longitudinal axis **must** be parallel to the transport direction of the printed-circuit board.

The footprint must incorporate solder thieves at the downstream end.

- For packages with leads on four sides, the footprint must be placed at a 45° angle to the transport direction of the printed-circuit board. The footprint must incorporate solder thieves downstream and at the side corners.

During placement and before soldering, the package must be fixed with a droplet of adhesive. The adhesive can be applied by screen printing, pin transfer or syringe dispensing. The package can be soldered after the adhesive is cured.

Typical dwell time is 4 seconds at 250 °C.

A mildly-activated flux will eliminate the need for removal of corrosive residues in most applications.

**Manual soldering**

Fix the component by first soldering two diagonally-opposite end leads. Use a low voltage (24 V or less) soldering iron applied to the flat part of the lead. Contact time must be limited to 10 seconds at up to 300 °C.

When using a dedicated tool, all other leads can be soldered in one operation within 2 to 5 seconds between 270 and 320 °C.

## SDH/SONET STM1/OC3 laser drivers

TZA3031AHL; TZA3031BHL;  
TZA3031U

## Suitability of surface mount IC packages for wave and reflow soldering methods

PACKAGE	SOLDERING METHOD	
	WAVE	REFLOW <sup>(1)</sup>
BGA, LFBGA, SQFP, TFBGA	not suitable	suitable
HLQFP, HSQFP, HSOP, HTQFP, HTSSOP, SMS	not suitable <sup>(2)</sup>	suitable
PLCC <sup>(3)</sup> , SO, SOJ	suitable	suitable
LQFP, QFP, TQFP	not recommended <sup>(3)(4)</sup>	suitable
SSOP, TSSOP, VSO	not recommended <sup>(5)</sup>	suitable

## Notes

1. All surface mount (SMD) packages are moisture sensitive. Depending upon the moisture content, the maximum temperature (with respect to time) and body size of the package, there is a risk that internal or external package cracks may occur due to vaporization of the moisture in them (the so called popcorn effect). For details, refer to the Drypack information in the "Data Handbook IC26; Integrated Circuit Packages; Section: Packing Methods".
2. These packages are not suitable for wave soldering as a solder joint between the printed-circuit board and heatsink (at bottom version) can not be achieved, and as solder may stick to the heatsink (on top version).
3. If wave soldering is considered, then the package must be placed at a 45° angle to the solder wave direction. The package footprint must incorporate solder thieves downstream and at the side corners.
4. Wave soldering is only suitable for LQFP, TQFP and QFP packages with a pitch (e) equal to or larger than 0.8 mm; it is definitely not suitable for packages with a pitch (e) equal to or smaller than 0.65 mm.
5. Wave soldering is only suitable for SSOP and TSSOP packages with a pitch (e) equal to or larger than 0.65 mm; it is definitely not suitable for packages with a pitch (e) equal to or smaller than 0.5 mm.

## SDH/SONET STM1/OC3 laser drivers

TZA3031AHL; TZA3031BHL;  
TZA3031U**DEFINITIONS**

<b>Data sheet status</b>	
Objective specification	This data sheet contains target or goal specifications for product development.
Preliminary specification	This data sheet contains preliminary data; supplementary data may be published later.
Product specification	This data sheet contains final product specifications.
<b>Limiting values</b>	
Limiting values given are in accordance with the Absolute Maximum Rating System (IEC 60134). Stress above one or more of the limiting values may cause permanent damage to the device. These are stress ratings only and operation of the device at these or at any other conditions above those given in the Characteristics sections of the specification is not implied. Exposure to limiting values for extended periods may affect device reliability.	
<b>Application information</b>	
Where application information is given, it is advisory and does not form part of the specification.	

**LIFE SUPPORT APPLICATIONS**

These products are not designed for use in life support appliances, devices, or systems where malfunction of these products can reasonably be expected to result in personal injury. Philips customers using or selling these products for use in such applications do so at their own risk and agree to fully indemnify Philips for any damages resulting from such improper use or sale.

**BARE DIE DISCLAIMER**

All die are tested and are guaranteed to comply with all data sheet limits up to the point of wafer sawing for a period of ninety (90) days from the date of Philips' delivery. If there are data sheet limits not guaranteed, these will be separately indicated in the data sheet. There are no post packing tests performed on individual die or wafer. Philips Semiconductors has no control of third party procedures in the sawing, handling, packing or assembly of the die. Accordingly, Philips Semiconductors assumes no liability for device functionality or performance of the die or systems after third party sawing, handling, packing or assembly of the die. It is the responsibility of the customer to test and qualify their application in which the die is used.

---

SDH/SONET STM1/OC3 laser drivers

TZA3031AHL; TZA3031BHL;  
TZA3031U

---

**NOTES**

---

SDH/SONET STM1/OC3 laser drivers

TZA3031AHL; TZA3031BHL;  
TZA3031U

---

**NOTES**

---

SDH/SONET STM1/OC3 laser drivers

TZA3031AHL; TZA3031BHL;  
TZA3031U

---

**NOTES**

# Philips Semiconductors – a worldwide company

**Argentina:** see South America

**Australia:** 3 Figtree Drive, HOMEBUSH, NSW 2140,  
Tel. +61 2 9704 8141, Fax. +61 2 9704 8139

**Austria:** Computerstr. 6, A-1101 WIEN, P.O. Box 213,  
Tel. +43 1 60 101 1248, Fax. +43 1 60 101 1210

**Belarus:** Hotel Minsk Business Center, Bld. 3, r. 1211, Volodarski Str. 6,  
220050 MINSK, Tel. +375 172 20 0733, Fax. +375 172 20 0773

**Belgium:** see The Netherlands

**Brazil:** see South America

**Bulgaria:** Philips Bulgaria Ltd., Energoproject, 15th floor,  
51 James Bourchier Blvd., 1407 SOFIA,  
Tel. +359 2 68 9211, Fax. +359 2 68 9102

**Canada:** PHILIPS SEMICONDUCTORS/COMPONENTS,  
Tel. +1 800 234 7381, Fax. +1 800 943 0087

**China/Hong Kong:** 501 Hong Kong Industrial Technology Centre,  
72 Tat Chee Avenue, Kowloon Tong, HONG KONG,  
Tel. +852 2319 7888, Fax. +852 2319 7700

**Colombia:** see South America

**Czech Republic:** see Austria

**Denmark:** Sydhavnsgade 23, 1780 COPENHAGEN V,  
Tel. +45 33 29 3333, Fax. +45 33 29 3905

**Finland:** Sinikalliontie 3, FIN-02630 ESPOO,  
Tel. +358 9 615 800, Fax. +358 9 6158 0920

**France:** 51 Rue Carnot, BP317, 92156 SURESNES Cedex,  
Tel. +33 1 4099 6161, Fax. +33 1 4099 6427

**Germany:** Hammerbrookstraße 69, D-20097 HAMBURG,  
Tel. +49 40 2353 60, Fax. +49 40 2353 6300

**Hungary:** see Austria

**India:** Philips INDIA Ltd, Band Box Building, 2nd floor,  
254-D, Dr. Annie Besant Road, Worli, MUMBAI 400 025,  
Tel. +91 22 493 8541, Fax. +91 22 493 0966

**Indonesia:** PT Philips Development Corporation, Semiconductors Division,  
Gedung Philips, Jl. Buncit Raya Kav.99-100, JAKARTA 12510,  
Tel. +62 21 794 0040 ext. 2501, Fax. +62 21 794 0080

**Ireland:** Newstead, Clonskeagh, DUBLIN 14,  
Tel. +353 1 7640 000, Fax. +353 1 7640 200

**Israel:** RAPAC Electronics, 7 Kehilat Saloniki St, PO Box 18053,  
TEL AVIV 61180, Tel. +972 3 645 0444, Fax. +972 3 649 1007

**Italy:** PHILIPS SEMICONDUCTORS, Via Casati, 23 - 20052 MONZA (MI),  
Tel. +39 039 203 6838, Fax +39 039 203 6800

**Japan:** Philips Bldg 13-37, Kohnan 2-chome, Minato-ku,  
TOKYO 108-8507, Tel. +81 3 3740 5130, Fax. +81 3 3740 5057

**Korea:** Philips House, 260-199 Itaewon-dong, Yongsan-ku, SEOUL,  
Tel. +82 2 709 1412, Fax. +82 2 709 1415

**Malaysia:** No. 76 Jalan Universiti, 46200 PETALING JAYA, SELANGOR,  
Tel. +60 3 750 5214, Fax. +60 3 757 4880

**Mexico:** 5900 Gateway East, Suite 200, EL PASO, TEXAS 79905,  
Tel. +9-5 800 234 7381, Fax +9-5 800 943 0087

**Middle East:** see Italy

**Netherlands:** Postbus 90050, 5600 PB EINDHOVEN, Bldg. VB,  
Tel. +31 40 27 82785, Fax. +31 40 27 88399

**New Zealand:** 2 Wagener Place, C.P.O. Box 1041, AUCKLAND,  
Tel. +64 9 849 4160, Fax. +64 9 849 7811

**Norway:** Box 1, Manglerud 0612, OSLO,  
Tel. +47 22 74 8000, Fax. +47 22 74 8341

**Pakistan:** see Singapore

**Philippines:** Philips Semiconductors Philippines Inc.,  
106 Valero St. Salcedo Village, P.O. Box 2108 MCC, MAKATI,  
Metro MANILA, Tel. +63 2 816 6380, Fax. +63 2 817 3474

**Poland:** Al.Jerozolimskie 195 B, 02-222 WARSAW,  
Tel. +48 22 5710 000, Fax. +48 22 5710 001

**Portugal:** see Spain

**Romania:** see Italy

**Russia:** Philips Russia, Ul. Usatcheva 35A, 119048 MOSCOW,  
Tel. +7 095 755 6918, Fax. +7 095 755 6919

**Singapore:** Lorong 1, Toa Payoh, SINGAPORE 319762,  
Tel. +65 350 2538, Fax. +65 251 6500

**Slovakia:** see Austria

**Slovenia:** see Italy

**South Africa:** S.A. PHILIPS Pty Ltd., 195-215 Main Road Martindale,  
2092 JOHANNESBURG, P.O. Box 58088 Newville 2114,  
Tel. +27 11 471 5401, Fax. +27 11 471 5398

**South America:** Al. Vicente Pinzon, 173, 6th floor,  
04547-130 SÃO PAULO, SP, Brazil,  
Tel. +55 11 821 2333, Fax. +55 11 821 2382

**Spain:** Balmes 22, 08007 BARCELONA,  
Tel. +34 93 301 6312, Fax. +34 93 301 4107

**Sweden:** Kottbygatan 7, Akalla, S-16485 STOCKHOLM,  
Tel. +46 8 5985 2000, Fax. +46 8 5985 2745

**Switzerland:** Allmendstrasse 140, CH-8027 ZÜRICH,  
Tel. +41 1 488 2741 Fax. +41 1 488 3263

**Taiwan:** Philips Semiconductors, 6F, No. 96, Chien Kuo N. Rd., Sec. 1,  
TAIPEI, Taiwan Tel. +886 2 2134 2886, Fax. +886 2 2134 2874

**Thailand:** PHILIPS ELECTRONICS (THAILAND) Ltd.,  
209/2 Sanpavuth-Bangna Road Prakanong, BANGKOK 10260,  
Tel. +66 2 745 4090, Fax. +66 2 398 0793

**Turkey:** Yukari Dudullu, Org. San. Blg., 2.Cad. Nr. 28 81260 Umraniye,  
ISTANBUL, Tel. +90 216 522 1500, Fax. +90 216 522 1813

**Ukraine:** PHILIPS UKRAINE, 4 Patrice Lumumba str., Building B, Floor 7,  
252042 KIEV, Tel. +380 44 264 2776, Fax. +380 44 268 0461

**United Kingdom:** Philips Semiconductors Ltd., 276 Bath Road, Hayes,  
MIDDLESEX UB3 5BX, Tel. +44 208 730 5000, Fax. +44 208 754 8421

**United States:** 811 East Arques Avenue, SUNNYVALE, CA 94088-3409,  
Tel. +1 800 234 7381, Fax. +1 800 943 0087

**Uruguay:** see South America

**Vietnam:** see Singapore

**Yugoslavia:** PHILIPS, Trg N. Pasica 5/v, 11000 BEOGRAD,  
Tel. +381 11 3341 299, Fax.+381 11 3342 553

**For all other countries apply to:** Philips Semiconductors,  
International Marketing & Sales Communications, Building BE-p, P.O. Box 218,  
5600 MD EINDHOVEN, The Netherlands, Fax. +31 40 27 24825

**Internet:** <http://www.semiconductors.philips.com>

© Philips Electronics N.V. 2000

SCA 69

All rights are reserved. Reproduction in whole or in part is prohibited without the prior written consent of the copyright owner.

The information presented in this document does not form part of any quotation or contract, is believed to be accurate and reliable and may be changed without notice. No liability will be accepted by the publisher for any consequence of its use. Publication thereof does not convey nor imply any license under patent- or other industrial or intellectual property rights.

Printed in The Netherlands

403510/150/03/pp32

Date of release: 2000 Feb 22

Document order number: 9397 750 06873

*Let's make things better.*

**Philips**  
Semiconductors



**PHILIPS**