

DATA SHEET

For a complete data sheet, please also download:

- The IC06 74HC/HCT/HCU/HCMOS Logic Family Specifications
- The IC06 74HC/HCT/HCU/HCMOS Logic Package Information
- The IC06 74HC/HCT/HCU/HCMOS Logic Package Outlines

74HC/HCT193

Presetable synchronous 4-bit
binary up/down counter

Product specification
File under Integrated Circuits, IC06

December 1990

Presettable synchronous 4-bit binary up/down counter

74HC/HCT193

FEATURES

- Synchronous reversible 4-bit binary counting
- Asynchronous parallel load
- Asynchronous reset
- Expandable without external logic
- Output capability: standard
- I_{CC} category: MSI

GENERAL DESCRIPTION

The 74HC/HCT193 are high-speed Si-gate CMOS devices and are pin compatible with low power Schottky TTL (LSTTL). They are specified in compliance with JEDEC standard no. 7A.

The 74HC/HCT193 are 4-bit synchronous binary up/down counters. Separate up/down clocks, CP_U and CP_D respectively, simplify operation. The outputs change state synchronously with the LOW-to-HIGH transition of either clock input. If the CP_U clock is pulsed while CP_D is held HIGH, the device will count up. If the CP_D clock is pulsed while CP_U is held HIGH, the device will count down. Only one clock input can be held HIGH at any time, or erroneous operation will result. The device can be cleared at any time by the asynchronous master reset input (MR); it may also be loaded in parallel by activating the asynchronous parallel load input (\overline{PL}).

The "193" contains four master-slave JK flip-flops with the necessary steering logic to provide the asynchronous reset, load, and synchronous count up and count down functions.

Each flip-flop contains JK feedback from slave to master, such that a LOW-to-HIGH transition on the CP_D input will decrease the count by one, while a similar transition on the CP_U input will advance the count by one.

One clock should be held HIGH while counting with the other, otherwise the circuit will either count by two's or not at all, depending on the state of the first flip-flop, which cannot toggle as long as either clock input is LOW. Applications requiring reversible operation must make the reversing decision while the activating clock is HIGH to avoid erroneous counts.

The terminal count up (\overline{TC}_U) and terminal count down (\overline{TC}_D) outputs are normally HIGH. When the circuit has reached the maximum count state of 15, the next HIGH-to-LOW transition of CP_U will cause \overline{TC}_U to go LOW.

\overline{TC}_U will stay LOW until CP_U goes HIGH again, duplicating the count up clock.

Likewise, the \overline{TC}_D output will go LOW when the circuit is in the zero state and the CP_D goes LOW. The terminal count outputs can be used as the clock input signals to the next higher order circuit in a multistage counter, since they duplicate the clock waveforms. Multistage counters will not be fully synchronous, since there is a slight delay time difference added for each stage that is added.

The counter may be preset by the asynchronous parallel load capability of the circuit. Information present on the parallel data inputs (D₀ to D₃) is loaded into the counter and appears on the outputs (Q₀ to Q₃) regardless of the conditions of the clock inputs when the parallel load (\overline{PL}) input is LOW. A HIGH level on the master reset (MR) input will disable the parallel load gates, override both clock inputs and set all outputs (Q₀ to Q₃) LOW. If one of the clock inputs is LOW during and after a reset or load operation, the next LOW-to-HIGH transition of that clock will be interpreted as a legitimate signal and will be counted.

Presetable synchronous 4-bit binary up/down counter

74HC/HCT193

QUICK REFERENCE DATAGND = 0 V; $T_{amb} = 25\text{ }^{\circ}\text{C}$; $t_r = t_f = 6\text{ ns}$

SYMBOL	PARAMETER	CONDITIONS	TYPICAL		UNIT
			HC	HCT	
t_{PHL}/t_{PLH}	propagation delay CP_D, CP_U to Q_n	$C_L = 15\text{ pF}; V_{CC} = 5\text{ V}$	20	20	ns
f_{max}	maximum clock frequency		45	47	MHz
C_I	input capacitance		3.5	3.5	pF
C_{PD}	power dissipation capacitance per package	notes 1 and 2	24	26	pF

Notes

- C_{PD} is used to determine the dynamic power dissipation (P_D in μW):

$$P_D = C_{PD} \times V_{CC}^2 \times f_i + \sum (C_L \times V_{CC}^2 \times f_o) \text{ where:}$$

f_i = input frequency in MHz

f_o = output frequency in MHz

$\sum (C_L \times V_{CC}^2 \times f_o)$ = sum of outputs

C_L = output load capacitance in pF

V_{CC} = supply voltage in V

- For HC the condition is $V_I = \text{GND to } V_{CC}$
For HCT the condition is $V_I = \text{GND to } V_{CC} - 1.5\text{ V}$

ORDERING INFORMATION

See *"74HC/HCT/HCU/HCMOS Logic Package Information"*.

Presetable synchronous 4-bit binary
up/down counter

74HC/HCT193

PIN DESCRIPTION

PIN NO.	SYMBOL	NAME AND FUNCTION
3, 2, 6, 7	Q ₀ to Q ₃	flip-flop outputs
4	CP _D	count down clock input ⁽¹⁾
5	CP _U	count up clock input ⁽¹⁾
8	GND	ground (0 V)
11	\overline{PL}	asynchronous parallel load input (active LOW)
12	\overline{TC}_U	terminal count up (carry) output (active LOW)
13	\overline{TC}_D	terminal count down (borrow) output (active LOW)
14	MR	asynchronous master reset input (active HIGH)
15, 1, 10, 9	D ₀ to D ₃	data inputs
16	V _{CC}	positive supply voltage

Note

1. LOW-to-HIGH, edge triggered

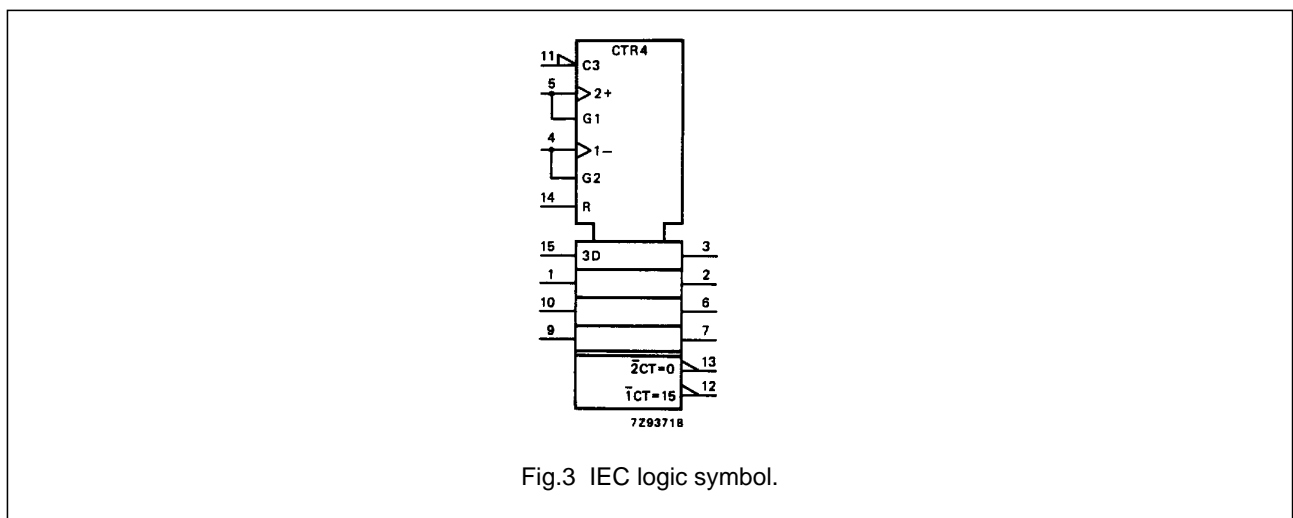
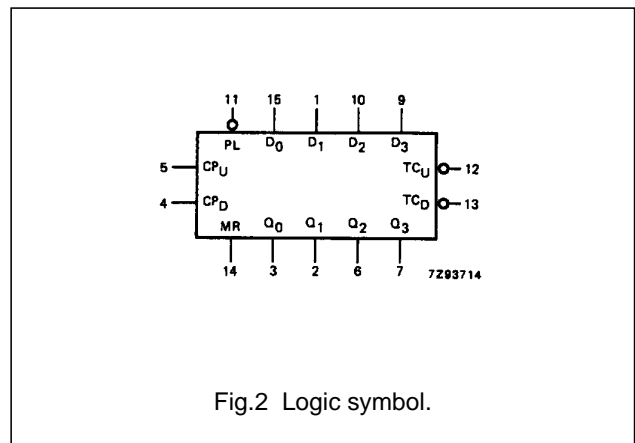
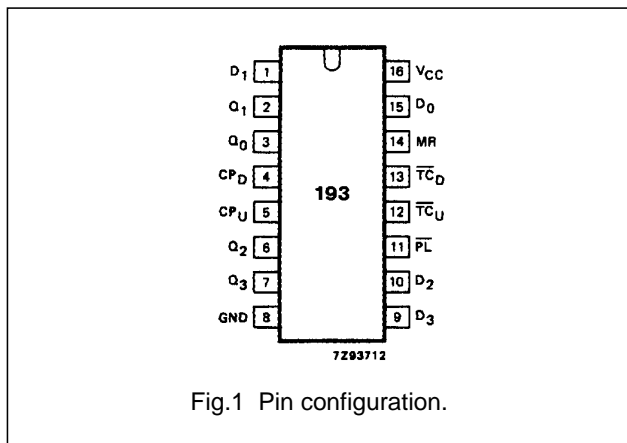

Pre-settable synchronous 4-bit binary
up/down counter

74HC/HCT193

FUNCTION TABLE

OPERATING MODE	INPUTS								OUTPUTS					
	MR	\overline{PL}	CP_U	CP_D	D_0	D_1	D_2	D_3	Q_0	Q_1	Q_2	Q_3	$\overline{TC_U}$	$\overline{TC_D}$
reset (clear)	H	X	X	L	X	X	X	X	L	L	L	L	H	L
	H	X	X	H	X	X	X	X	L	L	L	L	H	H
parallel load	L	L	X	L	L	L	L	L	L	L	L	L	H	L
	L	L	X	H	L	L	L	L	L	L	L	L	H	H
	L	L	L	X	H	H	H	H	H	H	H	H	L	H
	L	L	H	X	H	H	H	H	H	H	H	H	H	H
count up	L	H	↑	H	X	X	X	X	count up			H ⁽²⁾	H	
count down	L	H	H	↑	X	X	X	X	count down			H	H ⁽³⁾	

Notes

- H = HIGH voltage level
L = LOW voltage level
X = don't care
↑ = LOW-to-HIGH clock transition
- $\overline{TC_U}$ = CP_U at terminal count up (HHHH)
- $\overline{TC_D}$ = CP_D at terminal count down (LLLL)

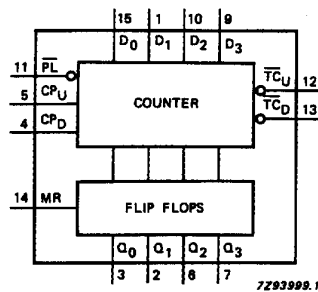
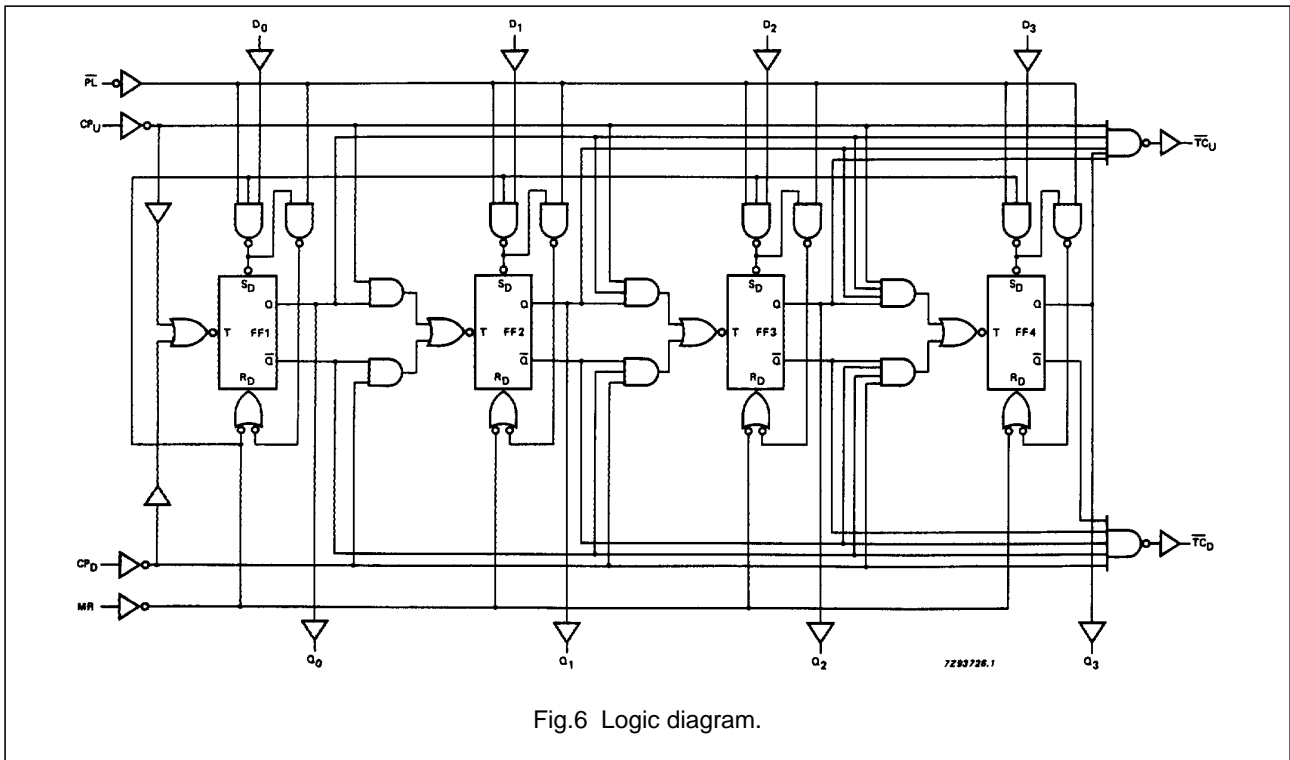
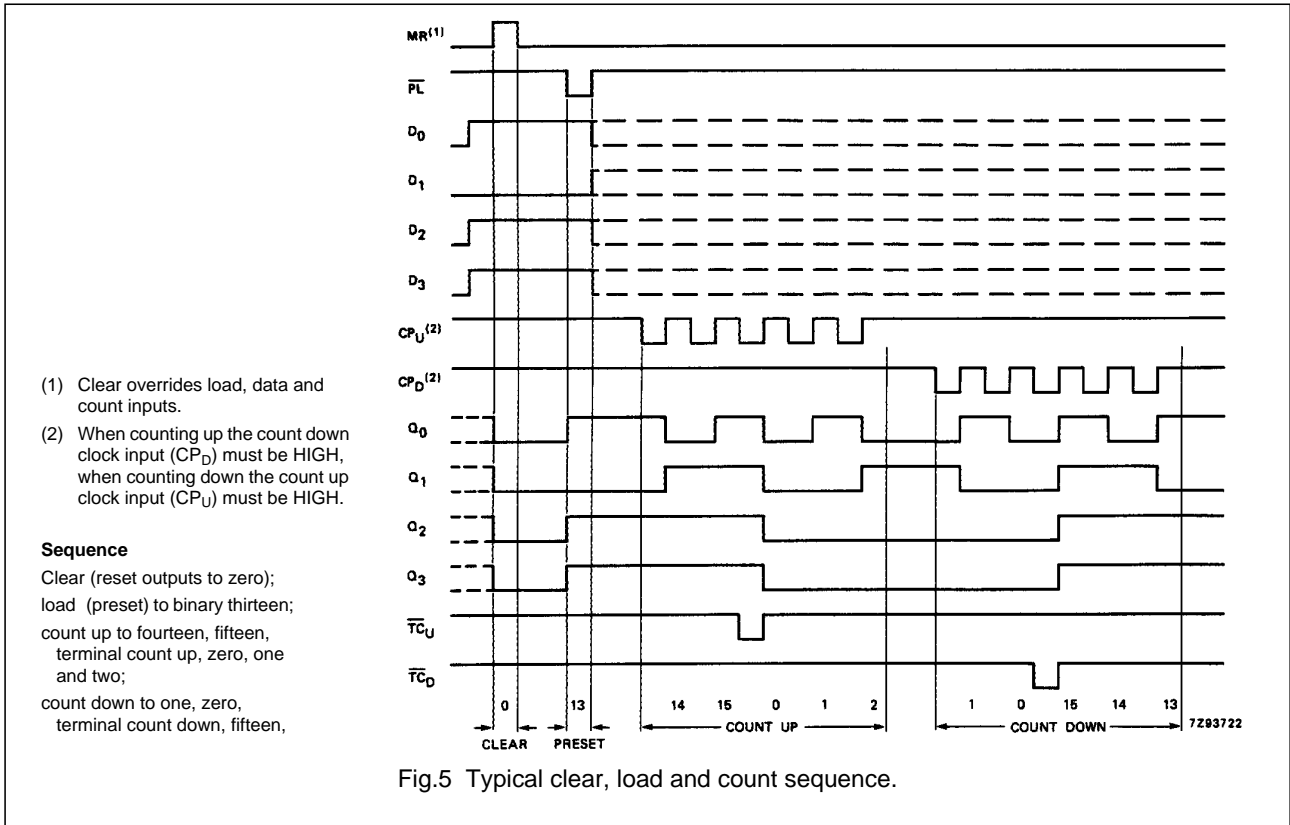

Fig.4 Functional diagram.

Presetable synchronous 4-bit binary up/down counter

74HC/HCT193



Presetable synchronous 4-bit binary up/down counter

74HC/HCT193

DC CHARACTERISTICS FOR 74HC

For the DC characteristics see *"74HC/HCT/HCU/HCMOS Logic Family Specifications"*.

Output capability: standard

I_{CC} category: MSI

AC CHARACTERISTICS FOR 74HC

GND = 0 V; t_r = t_f = 6 ns; C_L = 50 pF

SYMBOL	PARAMETER	T _{amb} (°C)							UNIT	TEST CONDITIONS	
		74HC								V _{CC} (V)	WAVEFORMS
		+25			-40 to +85		-40 to +125				
		min.	typ.	max.	min.	max.	min.	max.			
t _{PHL} / t _{PLH}	propagation delay CP _U , CP _D to Q _n		63 23 18	215 43 37		270 54 46		325 65 55	ns	2.0 4.5 6.0	Fig.7
t _{PHL} / t _{PLH}	propagation delay CP _U to \overline{TC}_U		39 14 11	125 25 21		155 31 26		190 38 32	ns	2.0 4.5 6.0	Fig.8
t _{PHL} / t _{PLH}	propagation delay CP _D to \overline{TC}_D		39 14 11	125 25 21		155 31 26		190 38 32	ns	2.0 4.5 6.0	Fig.8
t _{PHL} / t _{PLH}	propagation delay \overline{PL} to Q _n		69 25 20	220 44 37		275 55 47		330 66 56	ns	2.0 4.5 6.0	Fig.9
t _{PHL}	propagation delay MR to Q _n		58 21 17	200 40 34		250 50 43		300 60 51	ns	2.0 4.5 6.0	Fig.10
t _{PHL} / t _{PLH}	propagation delay D _n to Q _n		69 25 20	210 42 36		265 53 45		315 63 54	ns	2.0 4.5 6.0	Fig.9
t _{PHL} / t _{PLH}	propagation delay \overline{PL} to \overline{TC}_U , \overline{PL} to \overline{TC}_D		80 29 23	290 58 49		365 73 62		435 87 74	ns	2.0 4.5 6.0	Fig.12
t _{PHL} / t _{PLH}	propagation delay MR to \overline{TC}_U , MR to \overline{TC}_D		74 27 22	285 57 48		355 71 60		430 86 73	ns	2.0 4.5 6.0	Fig.12
t _{PHL} / t _{PLH}	propagation delay D _n to \overline{TC}_U , D _n to \overline{TC}_D		80 29 23	290 58 49		365 73 62		435 87 74	ns	2.0 4.5 6.0	Fig.12
t _{THL} / t _{TLH}	output transition time		19 7 6	75 15 13		95 19 16		110 22 19	ns	2.0 4.5 6.0	Fig.10
t _w	up, down clock pulse width HIGH or LOW	100 20 17	22 8 6		125 25 21		150 30 26		ns	2.0 4.5 6.0	Fig.7

Presetable synchronous 4-bit binary up/down counter

74HC/HCT193

SYMBOL	PARAMETER	T _{amb} (°C)						UNIT	TEST CONDITIONS		
		74HC							V _{CC} (V)	WAVEFORMS	
		+25			-40 to +85		-40 to +125				
		min.	typ.	max.	min.	max.	min.				max.
t _w	master reset pulse width HIGH	100 20 17	25 9 7		125 25 21		150 30 26	ns	2.0 4.5 6.0	Fig.10	
t _w	parallel load pulse width LOW	100 20 17	19 7 6		125 25 21		150 30 26	ns	2.0 4.5 6.0	Fig.9	
t _{rem}	removal time \overline{PL} to CP _U , CP _D	50 10 9	8 3 2		65 13 11		75 15 13	ns	2.0 4.5 6.0	Fig.9	
t _{rem}	removal time MR to CP _U , CP _D	50 10 9	0 0 0		65 13 11		75 15 13	ns	2.0 4.5 6.0	Fig.10	
t _{su}	set-up time D _n to \overline{PL}	80 16 14	22 8 6		100 20 17		120 24 20	ns	2.0 4.5 6.0	Fig.11 note: CP _U = CP _D = HIGH	
t _h	hold time D _n to \overline{PL}	0 0 0	-14 -5 -4		0 0 0		0 0 0	ns	2.0 4.5 6.0	Fig.11	
t _h	hold time CP _U to CP _D , CP _D to CP _U	80 16 8	22 8 6		100 20 17		120 24 20	ns	2.0 4.5 6.0	Fig.13	
f _{max}	maximum up, down clock pulse frequency	4.0 20 24	13.5 41 49		3.2 16 19		2.6 13 15	MHz	2.0 4.5 6.0	Fig.7	

**Pre-settable synchronous 4-bit binary
up/down counter**

74HC/HCT193**DC CHARACTERISTICS FOR 74HCT**

For the DC characteristics see "*74HC/HCT/HCU/HCMOS Logic Family Specifications*".

Output capability: standard

I_{CC} category: MSI

Note to HCT types

The value of additional quiescent supply current (ΔI_{CC}) for a unit load of 1 is given in the family specifications. To determine ΔI_{CC} per input, multiply this value by the unit load coefficient shown in the table below.

INPUT	UNIT LOAD COEFFICIENT
D _n	0.35
CP _U , CP _D	1.40
\overline{PL}	0.65
MR	1.05

Presetable synchronous 4-bit binary up/down counter

74HC/HCT193

AC CHARACTERISTICS FOR 74HCTGND = 0 V; $t_r = t_f = 6$ ns; $C_L = 50$ pF

SYMBOL	PARAMETER	T_{amb} (°C)								UNIT	TEST CONDITIONS	
		74HCT									V_{CC} (V)	WAVEFORMS
		+25			-40 to +85		-40 to +125					
		min.	typ.	max.	min.	max.	min.	max.				
t_{PHL}/t_{PLH}	propagation delay CP _U , CP _D to Q _n		23	43		54		65	ns	4.5	Fig.7	
t_{PHL}/t_{PLH}	propagation delay CP _U to \overline{TC}_U		15	27		34		41	ns	4.5	Fig.8	
t_{PHL}/t_{PLH}	propagation delay CP _D to \overline{TC}_D		15	27		34		41	ns	4.5	Fig.8	
t_{PHL}/t_{PLH}	propagation delay \overline{PL} to Q _n		26	46		58		69	ns	4.5	Fig.9	
t_{PHL}	propagation delay MR to Q _n		22	40		50		60	ns	4.5	Fig.10	
t_{PHL}/t_{PLH}	propagation delay D _n to Q _n		27	46		58		69	ns	4.5	Fig.9	
t_{PHL}/t_{PLH}	propagation delay \overline{PL} to \overline{TC}_U , \overline{PL} to \overline{TC}_D		31	55		69		83	ns	4.5	Fig.12	
t_{PHL}/t_{PLH}	propagation delay MR to \overline{TC}_U , MR to \overline{TC}_D		29	55		69		83	ns	4.5	Fig.12	
t_{PHL}/t_{PLH}	propagation delay D _n to \overline{TC}_U , D _n to \overline{TC}_D		32	58		73		87	ns	4.5	Fig.12	
t_{THL}/t_{TLH}	output transition time		7	15		19		22	ns	4.5	Fig.10	
t_W	up, down clock pulse width HIGH or LOW	25	11		31		38		ns	4.5	Fig.7	
t_W	master reset pulse width HIGH	20	7		25		30		ns	4.5	Fig.10	
t_W	parallel load pulse width LOW	20	8		25		30		ns	4.5	Fig.9	
t_{rem}	removal time \overline{PL} to CP _U , CP _D	10	2		13		15		ns	4.5	Fig.9	
t_{rem}	removal time MR to CP _U , CP _D	10	0		13		15		ns	4.5	Fig.10	
t_{su}	set-up time D _n to \overline{PL}	16	8		20		24		ns	4.5	Fig.11 note: CP _U = CP _D = HIGH	
t_h	hold time D _n to \overline{PL}	0	-6		0		0		ns	4.5	Fig.11	
t_h	hold time CP _U to CP _D , CP _D to CP _U	16	7		20		24		ns	4.5	Fig.13	
f_{max}	maximum up, down clock pulse frequency	20	43		16		13		MHz	4.5	Fig.7	

Presetable synchronous 4-bit binary up/down counter

74HC/HCT193

AC WAVEFORMS

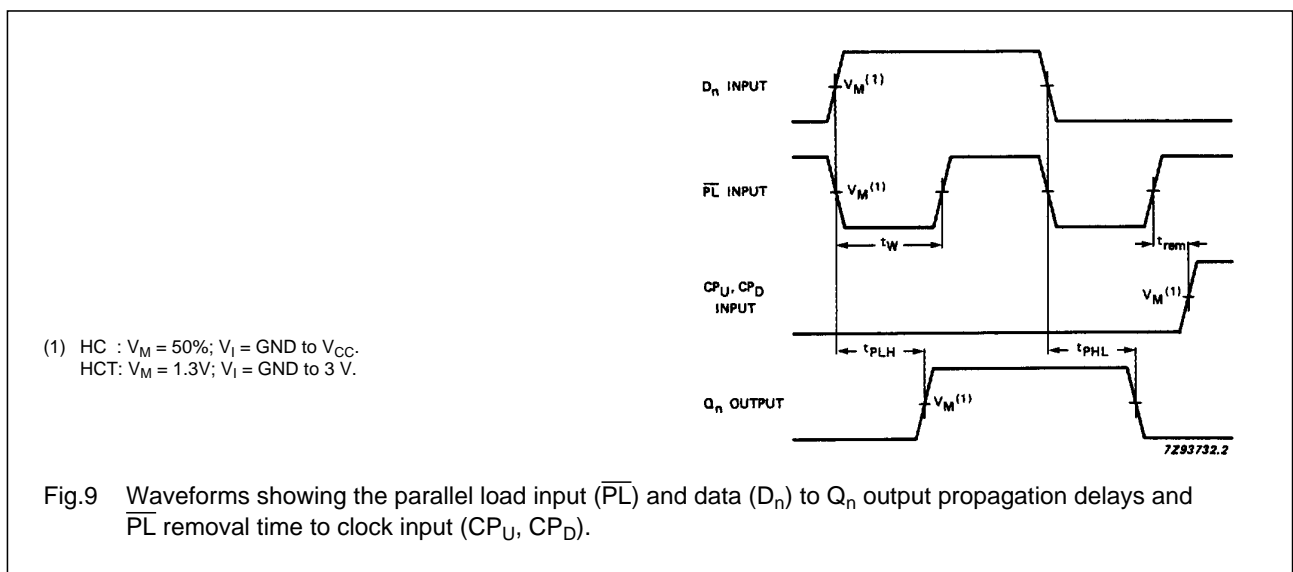
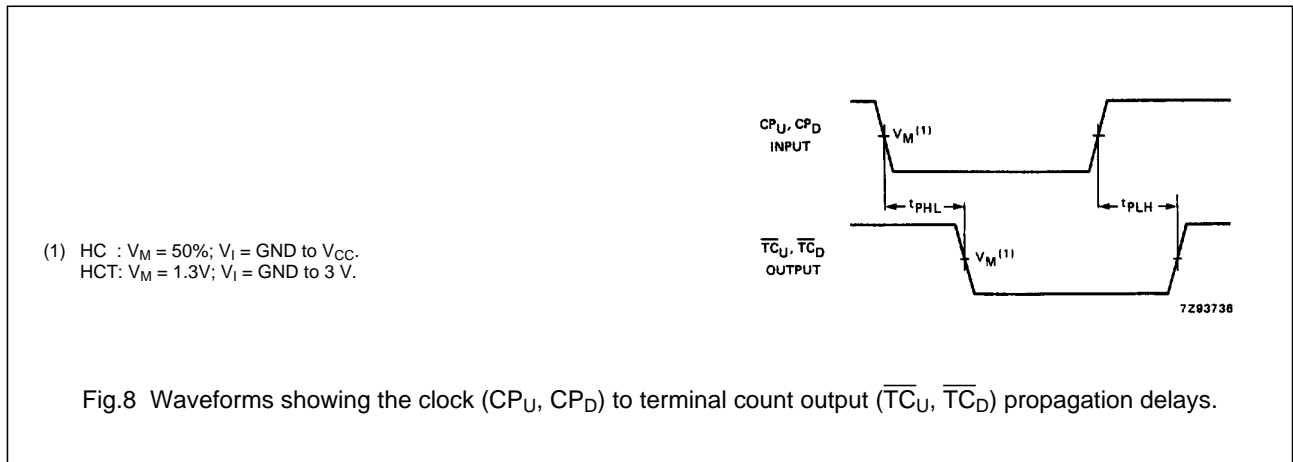
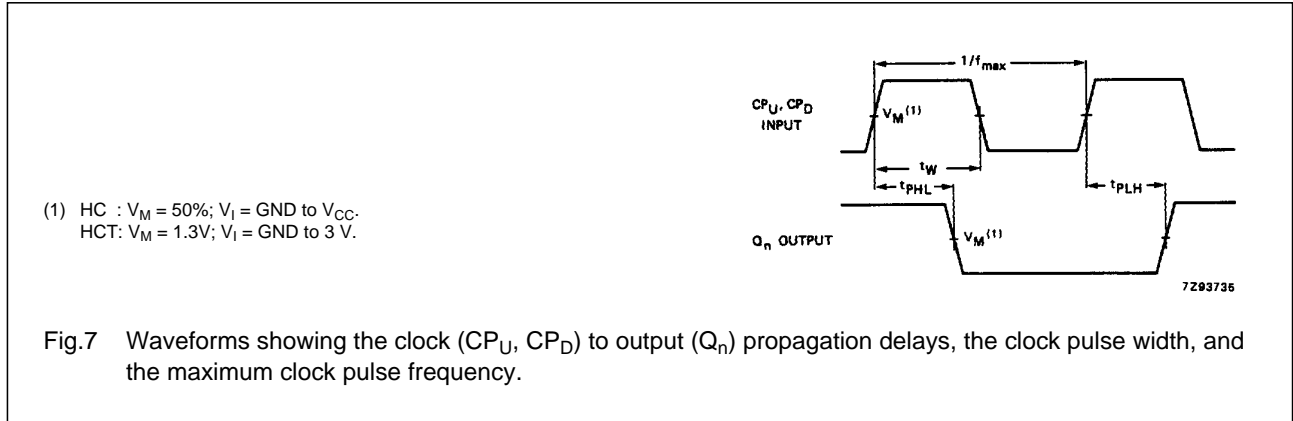

Presetable synchronous 4-bit binary up/down counter

74HC/HCT193

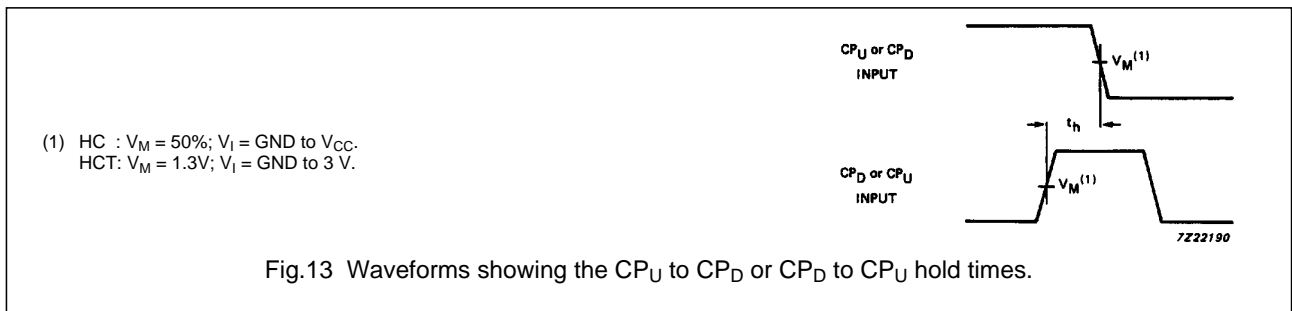
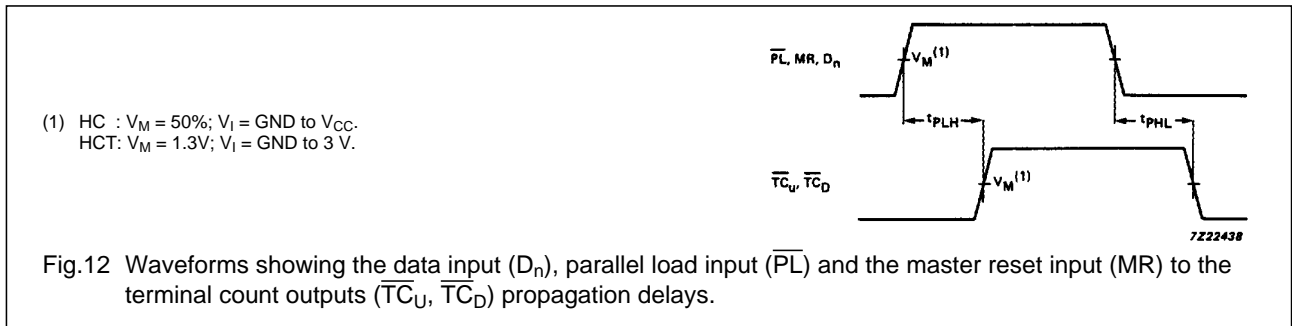
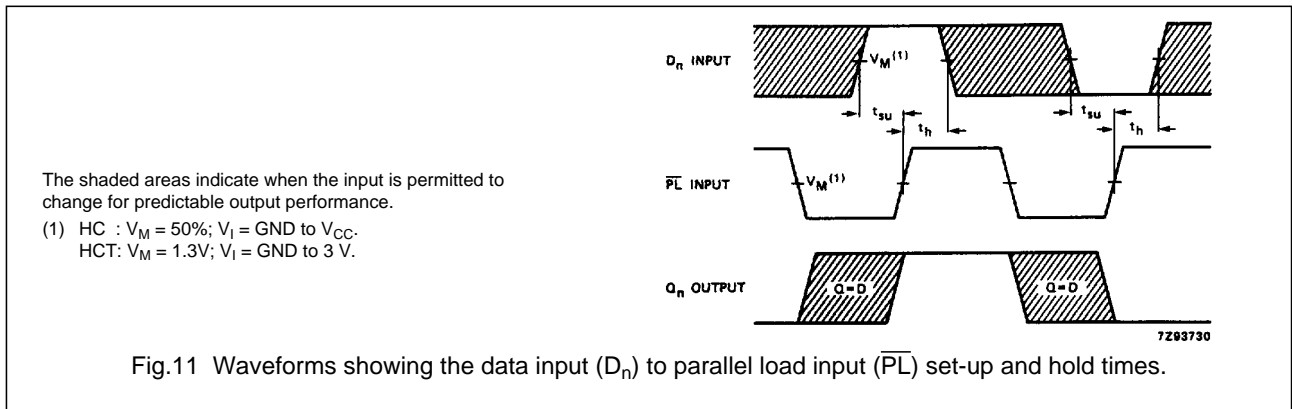
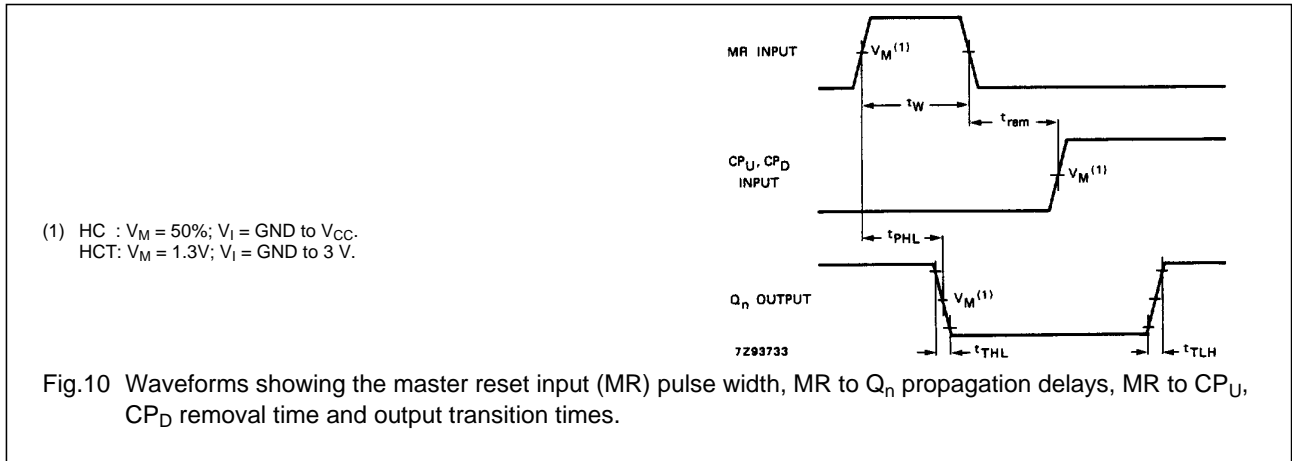

Presetable synchronous 4-bit binary
up/down counter

74HC/HCT193

APPLICATION INFORMATION

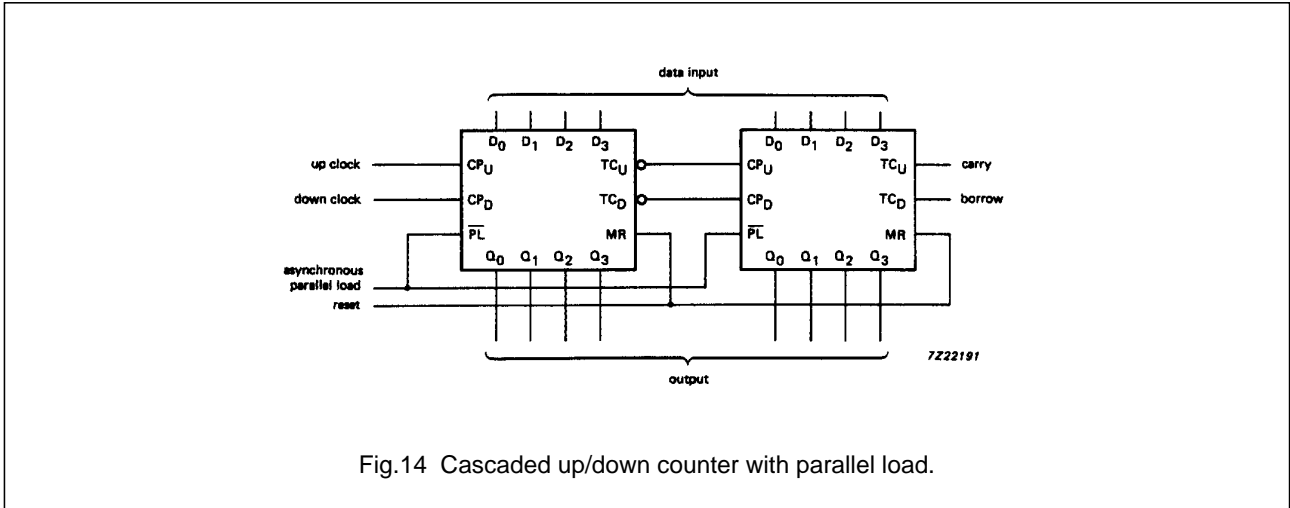

Fig.14 Cascaded up/down counter with parallel load.

PACKAGE OUTLINES

See *"74HC/HCT/HCU/HCMOS Logic Package Outlines"*.